

# Intelligent ARM Based Children Tracking System

Geetha M<sup>1</sup>, Arunkumar B<sup>2</sup>

PG Scholar<sup>1</sup>, Assistant professor<sup>2</sup>

Department of EEE, V.R.S College of Engineering and Technology  
Arasur, Tamilnadu, INDIA

<sup>1</sup>geethaanjali686@gmail.com

<sup>2</sup>arunvrs2011.gmail.com

**Abstract**— Recently, all over the world, the number of crime over children is increasing day by day. This paper presents ARM Based Children Tracking System Using Mobile Ad hoc network (MANET) to avoid crime, health monitoring of students and reduce worries among parents. However the existing system are not powerful enough to give information about the children accidents such as unintentional injuries at school environment and also does not provide concentration on sensing the body temperature of the child and intimating the same to its parents and school control room. The information about student such as in time and out time from Bus and campus, body temperature will be recorded, and the GPS/GSM system automatically sends information (SMS / Phone Call) to their parents.

**Index Terms**— ARM7, GPS, GSM, Temperature sensor, Phone call.

## I. INTRODUCTION

Children tracking system is widely used all over the world to assure parents that their wards are safe from suspicious actions and their kid is happy in school atmosphere without crying. The proposed system includes tracking the child's movement to and from school and measure the body temperature of the children, voice play back circuit is used to indicate whether the children is crying or not, accident detection switch is used to activate the auto dialer when there is a great vibration occurs to the children.

System developed by Yun young Nam and Jung Wook Park, uses "Cooperative Fusion Model of a Tri axial Accelerometer and a Barometric Pressure Sensor for preventing child accidents such as unintentional injuries at home. Falls are a frequent cause of injury in children. Accident and emergency departments and outpatient surveillance systems show that falls are one of the most common mechanisms of injuries that require medical care, and the most common nonfatal injury that at times needs hospitalization. In children younger than four years of age, most fall-related injuries occur at home [1].

System developed by Yuichiro MORI, et.al, uses "Autonomous Clustering technique" for managing groups of Android terminals attached to children in school [2]. The new generation children tracking system consists of tags which

collect information of children group, Android mobile terminals which each child holds, and the server which stores children tracking information. It results in lack of individual attention towards the children since the cluster head sends the information about the children group and not about each individual & also does not concentrate on child crying inside the school. It offers less security [2]. The system, using low-cost passive RFID tags, can be applied to AGV, automated robot position tracking devices, mobile devices, and location tracking devices. An RFID reader is equipped on the moving object, and RFID passive tags are fixed to the floor or ceiling to track the location. The tags detected by the reader have certain patterns to recognize the current position. Several possible position tracking algorithms can be developed through data analysis. The simple way to track the position is by averaging the center position [4].

## II. SYSTEM ARCHITECTURE

This section describes the conceptual design of Intelligent ARM based children tracking system is shown in (Fig.1). The children information is transmitted and received using GSM/GPS technology. Child module is fixed to each and every child. The position of the moving child is tracked by GPS and is sent to ARM7 microcontroller.

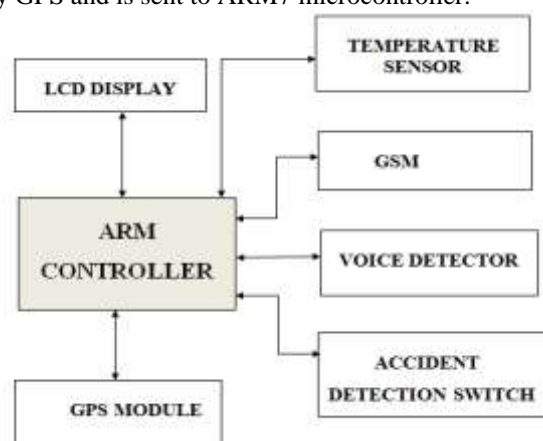

Fig.1a Transmitting Module

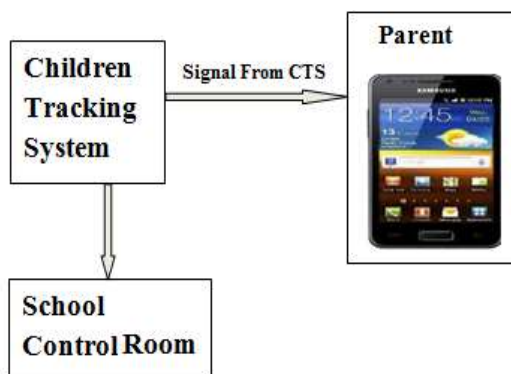

Fig.1b Receiver Module

The body temperature, accidental conditions also measured by using the child module and to provide a alert message when any injuries occurs to the child. The data from GPS receiver in NMEA format is received on ARM processor using UART1 protocol which contains Information about child position (longitude, latitude) and speed. This information can be check on the android mobile terminal using USB to serial convertor.

Design of hardware for children tracking system are used to track the location of the child and provide a safety to them in several ways like measuring the temperature of the child and send a alert message to the android mobile phone of parents. This design uses SIM300 GSM module that provide 900/1800/ 1900 MHz Tri-band for VOICE, SMS, DATA, and FAX.

### III. HARDWARE SYSTEM DESIGN

#### A. ARM7 (LPC 2148)

ARM architecture is based on Reduced Instruction Set Computer (RISC) principles, and the instruction set and related decode mechanism are much simpler than those of micro programmed Complex instruction Set Computers. This simplicity results in a high instruction throughput and impressive real-time interrupt response from a small and cost-effective processor core.

The LPC2141/2/4/6/8 microcontrollers are based on a 32/16 bit ARM7TDMI-S CPU with real-time emulation and embedded trace support, that combines the microcontroller with embedded high speed flash memory ranging from 32 kB to 512 kB. A 128-bit wide memory interface and a unique accelerator architecture enable 32-bit code execution at the maximum clock rate. For critical code size applications, the alternative 16-bit Thumb mode reduces code by more than 30 % with minimal performance penalty.

- 1) Single chip, high quality voice recording and playback solution.
- 2) User friendly, easy to use operation.
- 3) Non - Volatile - flash memory technology, no battery backup is required.
- 4) 4-8 KHz adjustable sampling rate can be done.
- 5) Audio output to drive a speaker or audio out for public address system.

#### B. Accident Detection Switch

The accident detection switch is used to make an automatic call to the parents and ambulance as soon as the accident has occurred. The auto dialer and the LPC2148 Microcontroller play a vital role in this detection. The main working is that the circuit is connected to the CTS (children tracking system) and as soon as the accident has occurred there is a great vibration in the children body because the CTS system is attached with the children. The vibration makes the auto dialer to activate. The auto dialer then makes a call to the number saved in its memory. The number saved may be the contact number of the nearest hospital. Then the ambulance can be able to arrive to the desired location as soon as possible. The microcontroller helps the auto dialer in transmitting and receiving the signals.

#### C. Global System for Mobile Communication

The most basic tele service supported by GSM is telephony. The transmitted data from ARM processor using UART1 module contains information about Children location that may be checked and displayed on the android mobile Terminal As with all other communications, speech is digitally encoded and transmitted through the GSM network as a digital stream. There is also an emergency service, where the nearest emergency-service provider is notified by dialing three digits (similar to 911).

A variety of data services is offered. GSM users can send and receive data, at rates up to 9600 bps, to users on POTS (Plain Old Telephone Service), ISDN, Packet Switched Public Data Networks, and Circuit Switched Public Data Networks using a variety of access methods and protocols, such as X.25 or X.32.

The advantage of GSM is, its Good subjective speech quality, Low terminal and service cost Support for international roaming, Ability to support handheld terminals, Support for range of new services and facilities, Spectral efficiency, ISDN compatibility.

#### D. Global Positioning System

The Global Positioning System (GPS) is a space-based satellite navigation system that provides location and

time information in all weather conditions, anywhere on or near the Earth where there is an unobstructed line of sight to four or more GPS satellites.

A GPS receiver calculates its position by precisely timing the signals sent by GPS satellites high above the Earth. Each satellite continually transmits messages that include the time the message was transmitted and, satellite position at time of message transmission. The receiver uses the messages it receives to determine the transit time of each message and computes the distance to each satellite using the speed of light. Each of these distances and satellites' locations defines a sphere, so the receiver is located at the point where the spheres intersect. These distances and satellites' locations are used to compute the location of the receiver using the navigation equations. With the advent of cellular communication and GPS positioning, objects may be tracked from just about anywhere.

#### E. Temperature Sensor

The temperature sensing is performed by using a LM35 IC. Human body needs special type of sensors for reliable Readings which led to the choice of using the LM35 Temperature Sensors in our prototype. It operates at 3 to 5 V and can measure temperature in the range of -40 C to +125 C which is sufficient for the targeted body temperature range. The sensor's output is an analog DC voltage signal which is read by the microcontroller using an analog pin linked to an ADC. The ADC used has a resolution of 10-bits, 1024 levels, with a sample rate of 9 600 Hz input voltage range depending on the ground and Vcc.

The temperature monitoring system main objective is to continuously measure body temperature. The system shall always check for three hazardous conditions which are maximum temperature, minimum temperature, and maximum temperature change over a specific period of time.

### IV. SOFTWARE SYSTEM DESIGN

#### A. Keil uVision4 MDK ARM

Keil $\mu$ Vision4 IDE (Integrated Development Environment) is a Windows based front end for the C Compiler and assembler. Keil $\mu$ Vision4 is used for writing embedded C programs. Embedded C is a high level language, which includes many aspects of the ANSI (American National Standard Institute) C programming language. This software is mainly used to activate ARM7 (lpc 2148) microcontroller according to the input received by it. "Embedded C" code is written using this work bench. In this project, coding is written for GPS, GSM and Voice playback circuit, measuring body temperature, fall detection of children of which is interfaced with ARM7 board at the transmitter end. As per the

code embedded in the controller, the interfaced modules generate appropriate output at the receiving end.

#### B. PROTEUS

Proteus 8 is a best simulation software for various designs with microcontroller. It is mainly popular because of availability of almost all microcontrollers in it. So it is a handy tool to test programs and embedded designs for electronics hobbyist. You can simulate your programming of microcontroller in Proteus 8 Simulation Software.

After simulating your circuit in Proteus 8 Software you can directly make PCB design with it so it could be a all in one package for students and hobbyists. So I think now you have a little bit idea about what is proteus software.

#### C. Visual Basic with .Net

Visual Basic .NET (VB.NET) is a multi-paradigm, high level programming language, implemented on the .NET Framework.

Microsoft launched VB.NET in 2002 as the successor to its original Visual Basic language. A combination of Visual Basic and .Net is used for the creation of monitoring database at school. This database includes all basic parameters to be known at this receiving end (control room of the school). Parameters include child details (ID no., Name, Phone number, body temperature, current position, etc...).

### V. RESULTS AND DISCUSSION



Fig 2 ARM7 Board (LPC 2148)

(Fig.2) illustrates LPC 2148 microcontroller. This controller filters the incoming GPS data which holds repeated

six packets and forwards only the latitude and longitude values (i.e.) current position of the child to GSM.



Fig. 3 voice play back circuit

(Fig.3) illustrates voice play back circuit The APR93 0 1 device stores and reproduces voice signals in their natural forms, eliminating the distortion that is often introduced by encoding and compression.



Fig. 4 GSM Board

GSM module (Fig.4) receives the latitude and longitude value of the child's current position and sends it to two receivers.

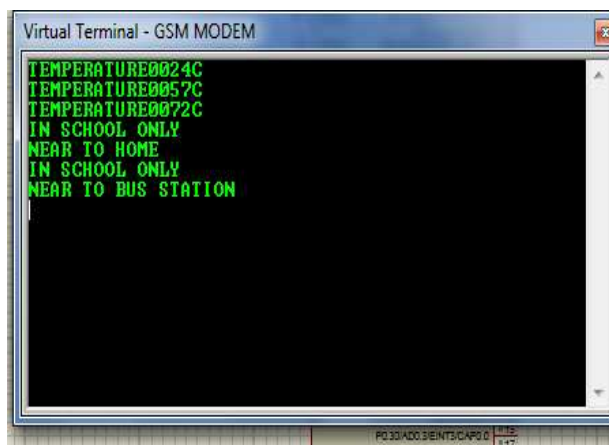

Fig 5. Simulation result

The above figure illustrates a simulation result of the proposed system.

## VI. CONCLUSION

This paper presents a low-power children tracking system, based on ARM using GSM and GPS on android mobile terminals. This project primarily focuses on tracking a child's position and its location and monitoring health condition of the child is sent to its parent and control room. It can be extended to perform the same for all children in the school by reducing the size of the child module, thus fixing it to body of every child. This project also focuses on tracking the accident zone of the school bus.

## REFERENCES

- [1].Yunyoung Nam and Jung Wook Park "Child Activity Recognition Based on Cooperative Fusion Model of a Triaxial Accelerometer and a Barometric Pressure Sensor" proposed In IEEE Journal Of Biomedical And Health Informatics, Vol. 17, No. 2, March 2013,pp.420-426.
- [2]. Yuichiro MORI, Hideharu KOJIMA, Eitaro KOHNO,Shinji INOUE, Tomoyuki OHTA, and Yoshiaki KAKUDA, "A Self-Configurable New Generation Children Tracking System based on Mobile Ad Hoc Networks Consisting of Android Mobile Terminals" proposed in 2011 tenth International symposium on Autonomous decentralized systems. W.-K. Chen, *Linear Networks and Systems* (Book style). Belmont, CA: Wadsworth, 1993, pp. 123-135.
- [3] J. Saranya, J. Selvakumar "Implementation of Children Tracking System on Android Mobile Terminals" proposed in International conference on Communication and Signal Processing, April 3-5, 2013, India, pp. 961-965.
- [4] Jae Hyung Cho and Myeong-Woo Cho," Effective Position Tracking Using B-Spline Surface Equation Based on Wireless Sensor Networks and Passive UHF-RFID" proposed in IEEE Transactions On Instrumentation And Measurement, Vol. 62, No. 9, September 2013

[5] Lijun Jiang, Lim Nam Hoe, Lay Leong Loon, "Integrated UWB and GPS Location Sensing System in Hospital Environment", proposed in 2010 5th IEEE conference on Industrial Electronics and Applications.

[6] Tomoyuki Ohta, Shinji Inoue, Yoshiaki Kakuda, and Kenji Ishida, "An adaptive multihop clustering scheme for ad hoc networks with high mobility," IEICE Transactions on Fundamentals of Electronics, Communications and Computer Sciences (Special Issue on Multidimensional Mobile Information Networks), vol.E86-A, no.7, pp.1689-1697, 2003.

[7] Eitaro Kohno, Tomoyuki Ohta, and Yoshiaki Kakuda, "Secure decentralized data transfer against node capture attacks for wireless sensor networks," Proc. 9th IEEE International Symposium on Autonomous Decentralized Systems (ISADS2009), Athens, Greece, pp.35-40, 2009.

[8] Luo, S., Hu, Q. "A Dynamic Motion Pattern Analysis Approach to Fall Detection", in IEEE International Workshop on Biomedical Circuits & Systems, Singapore, 2004.

[9] N. Li, Y. Hou, and Z. Huang. (2011). A real-time algorithm based on triaxial accelerometer for the detection of human activity state. in *Proc. 6th Int. Conf. Body Area Netw.*, ser. BodyNets '11. ICST, Brussels, Belgium, Belgium: ICST (Institute for Computer Sciences, Social-Informatics and Telecommunications Engineering), [Online]. pp. 103-106. Available: <http://dl.acm.org/citation.cfm?id=2318776.2318801>

[10] Baker Mohammad, Hazem Elgabra, Reem Ashour, Hani Saleh " Portable Wireless Biomedical Temperature Monitoring System: Architecture and Implementation " .