

# LOAD FREQUENCY ANALYSIS OF AUTOMATIC GENERATION CONTROL SINGLE AREA NETWORK USING ANN AND GA

**SEEMA DAS**

Associate Professor, Department of Electronics & Communication Engineering  
Dronacharya College of Engineering, Gurgaon-123506, India  
Email: seema\_d12@rediffmail.com

**Hari Mohan Rai**

Assistant Professor, Department of Electronics & Communication Engineering  
Dronacharya College of Engineering, Gurgaon-123506, India

**Shailey Gulati**

Student, Department of Electronics & Communication Engineering  
Dronacharya College of Engineering, Gurgaon-123506, India

**Rinku Sanghwan**

Student, Department of Electronics & Communication Engineering  
Dronacharya College of Engineering, Gurgaon-123506, India

## ABSTRACT

This Paper presents decentralized control scheme for Load Frequency Control in a two-area Power System by appreciating the performance of the methods in a single area power system. A number of modern control techniques are adopted to implement a reliable stabilizing controller. A serious attempt has been undertaken aiming at investigating the load frequency control problem in a power system consisting of two power generation unit and multiple variable load units. The robustness and reliability of the various control schemes is examined through simulations. This paper deals with the automatic generation control (AGC) of interconnected thermal systems with combination of the automatic voltage control (AVR) and Demand Side Management (DSM). In this particular work thermal unit is considered with four area concept. The primary purpose of the AGC is to balance the total system generation against system load and losses so that the desired frequency and power interchange with neighbouring systems are maintained. Any mismatch between generation and demand causes the system frequency to deviate from scheduled value. Thus high frequency deviation may lead to system collapse. Further the role of automatic voltage regulator is to hold terminal voltage magnitude of synchronous generator at a specified level. The interaction between frequency deviation and voltage deviation is analyzed in this paper.

**Keywords:** Automatic generation control (AGC), ANN, Genetic Algorithm (GA)

## 1. INTRODUCTION

Automatic Generation Control (AGC) is one of the most important issues in electric power system design and operation. The objective of the AGC in an interconnected power system is to maintain the frequency of each area and to keep tie-line power close to the scheduled values by adjusting the MW outputs the AGC generators so as to accommodate fluctuating load demands. The automatic generation controller design with better performance has received considerable attention during the past years and many control strategies have been developed [1–4] for AGC problem. The availability of an accurate model of the system under study plays a crucial role in the development of the most control strategies like optimal control. However, an industrial process, such as a power system, contains different kinds of uncertainties due to changes in system parameters and characteristics, loads variation and errors in the modelling. On the other hand, the operating points of a power system may change very much randomly during a daily cycle. Because of this, a fixed controller based on classical theory [2–3] is certainly not suitable for AGC problem. Thus, some authors have suggested a variable structure [4–5] and neural networks methods [6–9] for dealing with parameter variations. All the proposed methods are based on the state-space approach and re-quire information about the system states which are not usually known or available.

In this paper, because of the inherent nonlinearity of power systems we address a new nonlinear Artificial Neural Network (ANN) controller based on  $\mu$ -synthesis technique. The motivation of using the  $\mu$ -based robust controller for training the proposed controller is to take the large parametric uncertainties and modelling error into account. To improve the stability of the overall system and also its good dynamic performance achievement, the ANN controller has been reconstructed with applying

the  $\mu$ -based robust controller to power systems in different operating points under different load disturbances by using the learning capability of the neural networks.

Genetic algorithm (GA) is an optimization method based on the mechanics of natural selection. In nature, weak and unfit species within their environment are faced with extinction by natural selection. The strong ones have greater opportunity to pass their genes to future generations. In the long run, species carrying the correct combination in their genes become dominant in their population. Sometimes, during the slow process of evolution, random changes may occur in genes. If these changes provide additional advantages in the challenge for survival, new species evolve from the old ones. Unsuccessful changes are eliminated by natural selection. In real-coded genetic algorithm (RCGA), a solution is directly represented as a vector of real parameter decision variables, representation of the solutions very close to the natural formulation of the problem [8], [4]. The use of floating-point numbers in the GA representation has a number of advantages over binary encoding. The efficiency of the GA gets increased as there is no need to encode/decode the solution variables into the binary type

## 2.MATHEMATICAL MODELLING

The objective here is to minimize the deviation in the frequency of two areas and the deviation in the tie line power flows and these variations are weighted together by a linear combination to a single variable called the ACE. The fitness function is taken as the Integral of time multiplied absolute value of ACE at every discrete time instant in the simulation [1], [2]. An optional penalty term is added to take care of the transient response specifications viz. transient response specifications on system frequency settling time, over shoots, etc. Integral of time multiplied absolute value of the Error (ITAE), is given by

$$\frac{2H}{\omega} \frac{d^2 \Delta \delta}{dt^2} = \Delta P_m - \Delta P_g$$

Taking Laplace Transform, we obtain

$$\Delta \Omega(s) = \frac{1}{2Hs} [\Delta P_m(s) - \Delta P_g(s)] \quad (1)$$

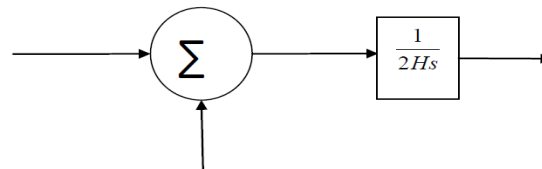

**Fig .1:** Represent the Block diagram of Generator

### 2.1Mathematical Modelling of Load

The load on the power system consists of a variety of electrical drives. The equipments used for lighting purposes are basically resistive in nature and the rotating devices are basically a composite of the resistive and inductive components. The speed-load characteristic of the composite load is given by

$$\Delta P_e = \Delta P_L + D \Delta \omega \quad (2)$$

where  $\Delta P_L$  is the non-frequency- sensitive load change,  $D \Delta \omega$  is the frequency sensitive load change.  $D$  is expressed as percent change in load by percent change in frequency

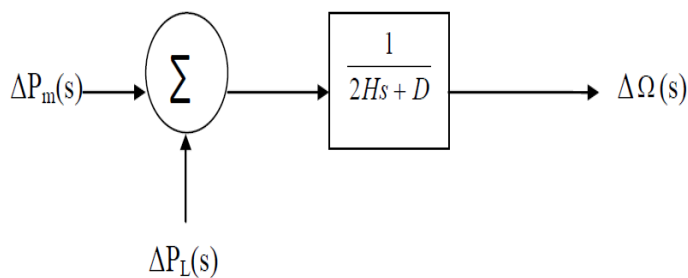

Fig .2: Represent the Block diagram of Load

2.2 Mathematical Modelling for Governor

$$\Delta P_g = \Delta P_{ref} - \frac{1}{R} \Delta f \tag{3}$$

Or in s- domain

$$\Delta P_g(s) = \Delta P_{ref} - \frac{1}{R} \Delta f \tag{4}$$

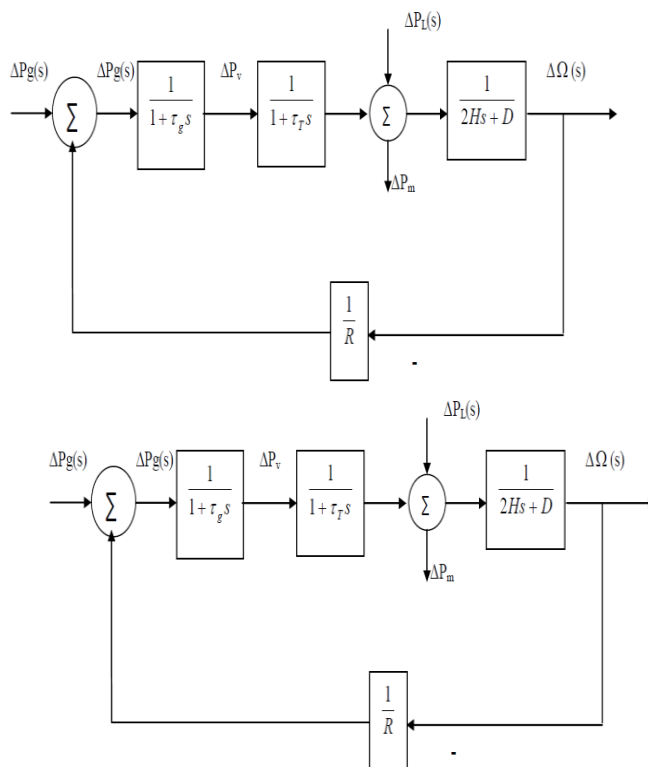

Fig .3 : Represent the Block diagram of Governor

$$\Delta P_v(s) = \frac{1}{1 + \tau_s} \Delta P_e(s) \tag{5}$$

3. SINGLE AREA NETWORK WITH NEURAL NETWORK

In this section we studies the Response of two area AGC using Neural Network in terms of frequency load variation for different gain value. In fig.4. As neural network, in we used NARMA-L2 controller to controlling the load frequency. Also we used feed forward neural network to controlling load frequency ,the ANN controller architecture employed here is Non linear Auto Regressive Model reference Adaptive Controller. It consists of reference, plant output and control signal. The plant output is forced to track the reference model output. Here, the effect of controller changes on plant output is predicted. It permits the updating of controller parameters. In the study, the frequency deviations, tie-line power deviation and load perturbation of the area are chosen as the neural network controller

inputs. Control signals applied to the governors in the area act as the outputs of the neural network. The data required for the ANN controller training is obtained by designing the Reference Model Neural Network and applying to the power system with step response load disturbances.

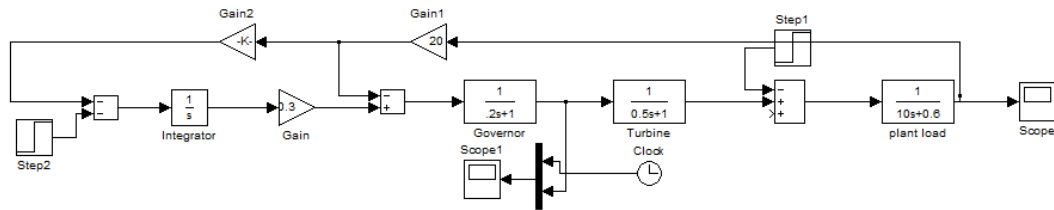

Fig .4: Simulink Block Diagram Single Area network

#### 4. OPTIMAL CONTROL METHOD USING GENETIC ALGORITHM

An optimal AGC strategy based on the linear state regulatory theory requires the feedback of all state variables of the system for its implementation, and an optimal control feedback law is obtained by solving the non-linear Riccati equation using suitable computational technique. To illustrate the effectiveness of the proposed control design and the algorithm to tune the feedback gains to the controller, a two area Restructured power system having two GENCOs and two DISCOs in each area is considered. The time-invariant state space for fig.5 representation as:

$$\dot{X} = A.X + B.U \tag{6}$$

$$Y = C.X \tag{7}$$

Where X is the state vector and U is the vector of contracted and un-contracted power demands of the DISCOs

$$X = [ \Delta f1 \ \Delta f2 \ \Delta Pg1 \ \Delta Pg2 \ \Delta Pg3 \ \Delta Pg4 \ \int ACE1 \ \int ACE2 \ \Delta Ptie12, act ]^T \tag{8}$$

$$\text{And } U = [ \Delta Pl1 \ \Delta Pl2 \ \Delta Pl3 \ \Delta Pl4 \ \Delta Pd1 \ \Delta Pd2 ]^T \tag{9}$$

for the system defined by the Eq.(6) and (7), the feedback control law is given as,

$$U = -K.Y \tag{10}$$

Where K is the feedback gain matrix. In this paper Evolutionary Genetic algorithms is used to optimize the feedback gains of the controller. Genetic algorithm (GA) is an optimization method based on the mechanics of natural selection. In nature, weak and unfit species within their environment are faced with extinction by natural selection. The efficiency of the GA gets increased as there is no need to encode/decode the solution variables into the binary type.

#### 5. CHROMOSOME STRUCTURE

In GA terminology, a solution vector known as an individual or a chromosome. Chromosomes are made of discrete units called genes. Each gene controls one or more features of the chromosome [9]. The chromosome string comprises of all feedback gains encoded as a string of real numbers.

##### 5.1 Fitness-Objective Function Evaluation

The objective here is to minimize the deviation in the frequency of two areas and the deviation in the tie line power flows and these variations are weighted together by a linear combination to a single variable called the ACE. The fitness function is taken as the Integral of time multiplied absolute value of ACE at every discrete time instant in the simulation [1], [2]

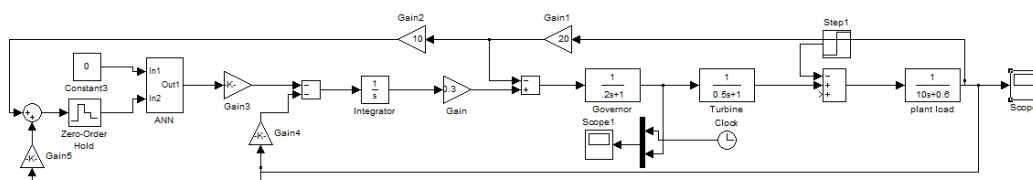

**Fig .5:** Simulink Block diagram of Single Area network with ANN

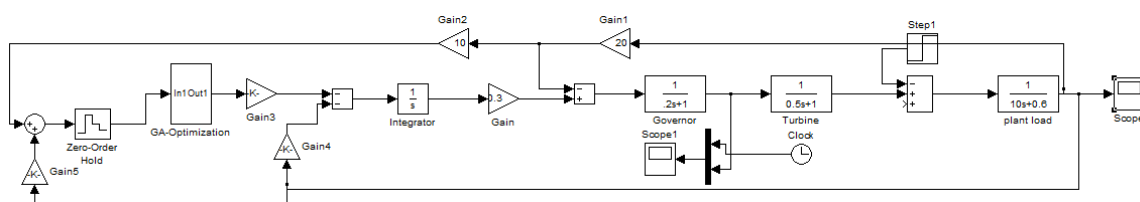

**Fig .6:** Simulink Block diagram of Single Area network with GA

## 6. SIMULATION AND RESULT

In this study simulations were performed using MATLAB® Simulink and Fuzzy Logic Toolbox on a two-equal area interconnected power system having steam turbine type thermal units in both areas. Two area network are interconnected power system has been developed using ANN and Genetic Algorithm controllers and integral controllers to demonstrate the performance of load frequency control using MATLAB/SIMULINK package. Fig. 5, 6, 7 & 8 respectively represent the plots of change in system frequency and tie-line power respectively for 1% step load variation.

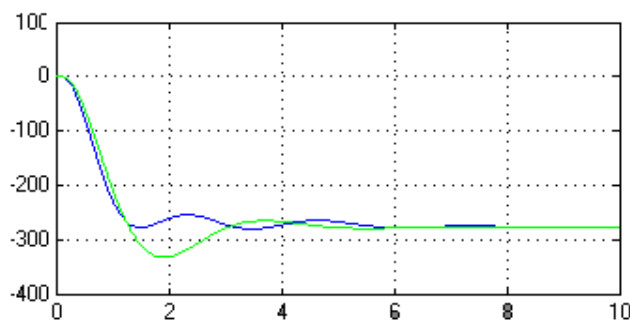

**Fig .7:** Response of load frequency of single area using ANN for different gain value. The above figure's is showing that response of AGC two are network for controlling the load frequency at 1-2%.for different gain value using ANN.

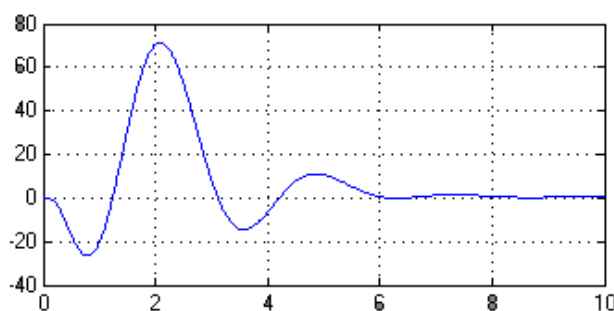

**Fig .8 :** Complete Response of 2% load frequency of single area using ANN for a gain value In this section we find the combined response of two are network for controlling the load frequency at 1-2% for different gain value using ANN

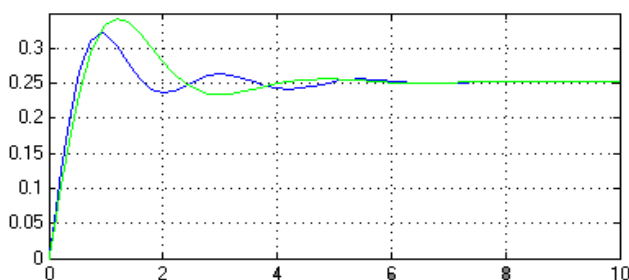

**Fig .9:** Response of load frequency of two area using GA for different gain value

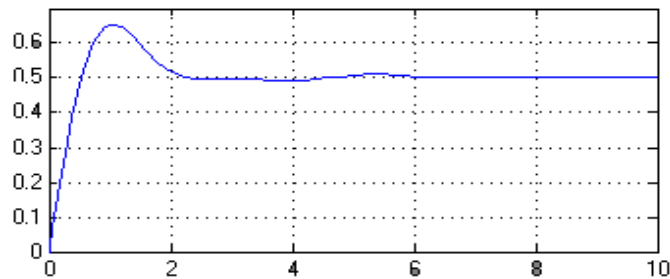

**Fig .10:** Complete Response of 2% load frequency of single area using GA for a gain value

## 7.CONCLUSION

This paper has offered a brief introduction to the basic application of Neural Network and Genetic algorithm for the controlling load frequency of Automatic Generation control two are network for different gain value for genetic algorithm we used optimization theory to find the exact or optimum value of network for different input data. The two area network consist of , a plant connected though tie line to delivered power in terms of frequency across load. The load value is depends on gain of governor of plant which is vary with power across load.

## REFERENCES

- [1] Karrari, M.—Shayeghi, H.—Menhaj, M. B.—Abedi,M. : Design of H1 Controller Load Frequency Control in Elec-tric Power Systems, Amirkabir Journal of Science & Technology 11 No. 41, 79–88. (1999)
- [2] Nanda, J.—Kavi, Bl. : Automatic Generation Control of Interconnected Power Systems, IEE Proc. on Gen. Tran. And Dis. 125 No. 5, 385–390. (1988)
- [3] Das,D.—Nanda, J.—Khothari,Ml.—Khothari, Dp. :Automatic Generation Control of Hydrothermal System withNew Area Control Error Considering Generation Rate Constant,Electric Machines and Power Systems 18, 461–467. (1990)
- [4] Jiang, H.—Cai, H.—Dorsey, F.—Qu, Z. : Toward a Glob- ally Robust Decentralized Control for Large-Scale Power Sys-tems, IEEE Trans. on Control System Technology 5 No.3, , 309–319. (1997)
- [5] Al-Hamouz, Z. M.—Al-Duwaish, H. N. : A New Load Fre-quency Variable Structure Controller Using Genetic Algorithms,Electric Power Systems Research 55 No. 1, 1–6. (2000)
- [6] Beaufays, F.—Abdel-Magid, Y.—Widrow, B. : Ap-plication of Neural Networks to Load Frequency Control in Power System, Neural Networks 7 No. 1, 183–194. (1994)
- [7] Zeynelgil, H. L.—Demiroren, A.—Sengor, N. S. :The Application of ANN Technique to Automatic Generation Control for Multi-Area Power System, Electrical Power and En-ergy Systems 24, 545–354. (2002)
- [8] A. Konak et al- Multi-objective optimization using genetic algorithms: A tutorial- / Reliability Engineering and System Safety 91 992–1007, (2006)
- [9] Pingkang Li1 Xiuxix Du, Multi-Area AGC System Performance Improvement Using GA Based Fuzzy Logic Control- The International Conference on Electrical Engineering,(2009)
- [10] Y. L. Karnavas, K. S. Dedousis, Overall performance evaluation of evolutionary designed conventional AGC controllers for interconnected electric power system studies in a deregulated market environment- International journal of Engineering, Science and Technology, Vol. 2, pp150-166 , (2010)
- [1] Elyas Rakhshani , Javad Sadeh, Practical viewpoints on load frequency control problem in a deregulated power system-Energy Conversion and Management 51,pp 1148–1156, (2010)
- [12] A. Konak et al, Multi-objective optimization using genetic algorithms: A tutorial- / Reliability Engineering and System Safety 91 992–1007,(2006)
- [13] V. Donde, M. Pai, I. Hiskens, Simulation and Optimization in an AGC System after Deregulation. IEEE Transactions on Power Systems, 16(3): 481–488 ,(2001)