

CPLD based Solar Power Saving System for Street Lights and Automatic Traffic Controller

Manoj Kumar.K^{#1}, Purandara Babu.N^{*2}, Triveni.M^{*3}, Ramesh Babu^{#4}

[#]P.G. Scholar (M. Tech), Dept. of ECE, AVR & SVR Engineering College, Kurnool, A.P, India, afcatmanoj@gmail.com

^{*}P.G. Scholar (M. Tech), Dept. of ECE, AVR & SVR Engineering College, Kurnool, A.P, India, puri.hyd@gmail.com

^{*}P.G. Scholar (M. Tech), Dept. of ECE, AVR & SVR Engineering College, Kurnool, A.P, India, mrudalatriveni@gmail.com

[#] Assistant Professor M. Tech, Dept. of ECE, AVR & SVR Engineering College, Kurnool, A.P, India .

Abstract- Solar energy is one of the major renewable sources and is non polluted. Hence, the utilization of this energy is essential everywhere where the maximum possibility of utilization of solar energy is there. One of such possibility is solar power to street lights and traffic systems. Hence, an attempt is made to implement the solar power saver system for street lights and automatic traffic control unit. The proposed system is implemented with MAX3032 Altera CPLD with 32 macro cells. An infrared sensor array is installed on the streets to know the presence of traffic. As there is a requirement of light only at night times, light detectors are used in the system to work it only in the absence of sun light when there is a presence of traffic. In this way the maximum power can be saved. Proposed cost effective system not only saves the power rather it reduces the usage of conventional energy. The proposed system logic is implemented using VHDL.

Keywords- Complex Programmable Logic Device (CPLD), Infrared Sensor (IRS), Very High Speed Integrated Circuit Hardware Description language (VHDL), Light Dependent Resistors (LDR).

I. INTRODUCTION

Street lighting provides a safe nighttime environment for all road users including pedestrians. Providing street lighting is one of the most important and expensive responsibilities of a city. Lighting can account for 10–38% of the total energy bill in typical cities worldwide. Street lighting is a particularly critical concern for public authorities in developing countries because of its strategic importance for economic and social stability. Inefficient lighting wastes significant financial resources every year, and poor lighting creates unsafe conditions. Energy efficient technologies and design mechanism can reduce cost of the street lighting drastically.

The implementation of street light intensity control using LUX meter, traffic sensor and complex sub control machines are in process in the Norway. (Oslo street light control)[6]. But the power consumption is reduced only by nearly 30%. There also exists a project in progress where in

the street light power consumption is reduced using a remote controlled system, but the disadvantage is that it is not cost effective and that the initial investment is not economical.

The main objective of the present study is to reduce the power consumption and efficient utilization of renewable sources for the application of street lightening and traffic signaling. Hence, this paper is aimed at design and implementation of an automatic system to control the traffic and reduce energy consumption of a town's public lighting system up to the maximum possible extent. The density of traffic is sensed by using an array of Passive Infrared Sensors (PIR), which senses the traffic movement. LDR is used to detect the presence of day light. The proposed system is able to control the traffic during the day as well as night. In this system, the streetlights are switched ON/OFF automatically during the presence of the traffic only during the nights.

II IMPLEMENTATION OF AUTOMATIC STREET LIGHT AND TRAFFIC CONTROL UNIT

The block diagram of proposed automatic street lightening and traffic control system corresponding to road safety is as shown in Fig.2. In this system, light presence will be detected by the Light Dependent Resistor (**LDR**). LDR is used to switch ON and OFF the street lights based on detecting the light ambiance. Depending upon the illumination level the resistance of the sensing element varies, which varies the voltage at its output. An analog to digital converter converts this voltage into digital form which is proportional to the intensity of the sun light present in the atmosphere. In the proposed system this job is done by the built in analog to digital converter (ADC) present in the CPLD (Complex Programmable Logic Device). Here MAX3032 Altera CPLD with 32 macro cells is used. A Complex Programmable Logic Device (CPLD) is a programmable logic device with complexity between that of PALs and FPGAs, and architectural features of both. The maximum clock frequency

is 20 MHz and hence it is faster than microcontroller. In the proposed system, traffic control unit is used, in which it will be controlled in four way junction by lighting the lights (Green, Red, Yellow and Orange) depending on density of the traffic with the help of the passive in sensors.

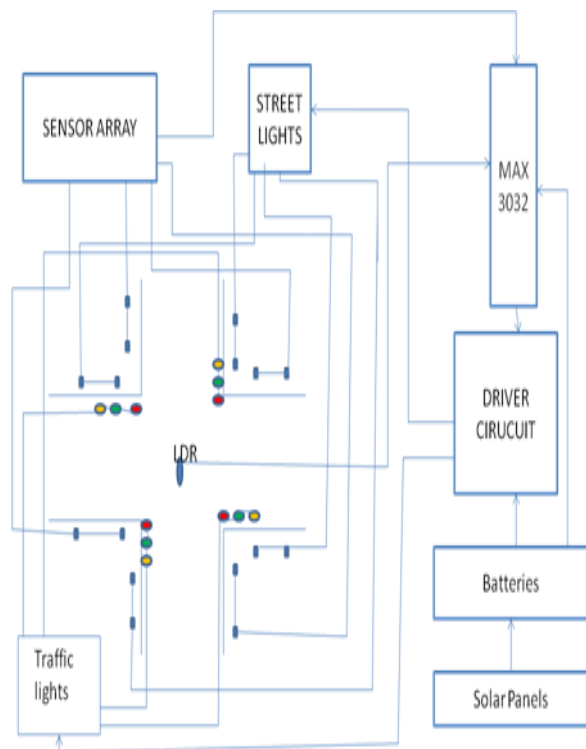

Fig.2: Block diagram of Street light and Traffic controller

The term 'passive' in this instance means the PIR does not emit energy of any type but merely accepts incoming infrared radiation. Apparent motion is detected using the variation in the IR rays emitted by the vehicles and this information is given to the CPLD. The Driver circuit drives the whole circuit with the help of Batteries which are charged with the help of Solar panels which absorbs the heat energy from the Sun.

III WORKING OF STREET LIGHT AND TRAFFIC CONTROLLER

The working of Street light and Traffic controller is explained with the help of flow chart as shown Fig.3. The proposed system will work only with the help of renewable source. The renewable source using here is sun light, the sun light is absorbed by solar panels. Through the photovoltaic effect, heat energy is converted in to electrical energy and it is stored in batteries. With the help of batteries the driver circuit can drive the street lights and traffic lights. Here with the help of renewable source, LDR and IR Sensor, CPLD makes the street lights to glow only at the absence of sun light and that to in the presence of traffic only.

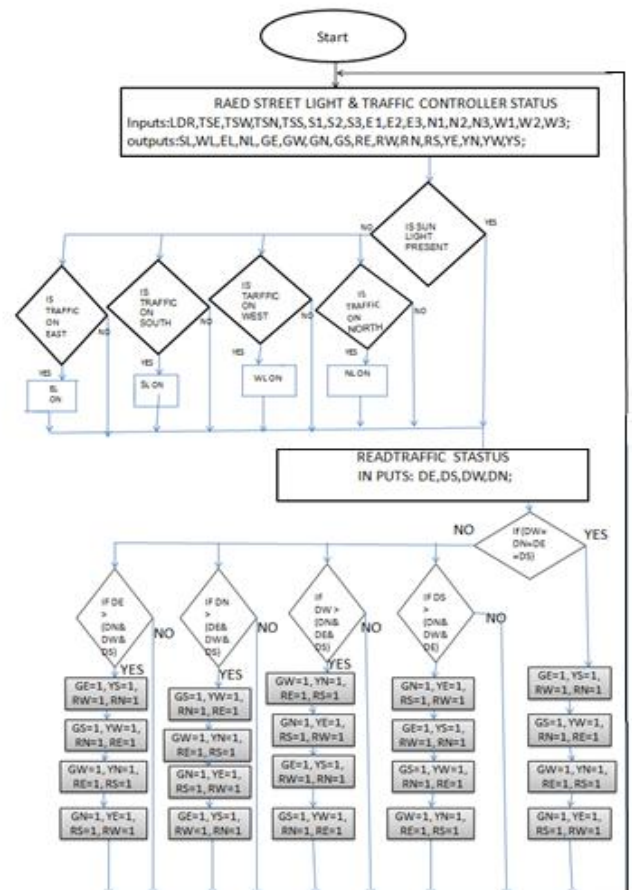

Fig.3: Flow chart of traffic and street light control

Even though in the presence of light or in the absence of light in the four way junction traffic controller the traffic density is measured by using IR sensors and that is passed to CPLD. If density of traffic is equal on four ways then priority is given to East side and the CPLD switch ON the green light on the East for prescribed time. If density of traffic is not equal on four sides then chooses any one of the following four conditions depending on traffic density.

- a) If traffic on East side is more then, it switches ON the green light on East side and yellow light on South side and red light on West and North side for the prescribed time and then again check the traffic density.
- b) If traffic on South side is more then, it switches ON the green light on South side and yellow light on West side and red light on North and East side for the prescribed time and then again check the traffic density.

- c) If traffic on West side is more then, it switches ON the green light on West side and yellow light on North side and red light on East and South side for the prescribed time and then again check the traffic density.
- d) If traffic on North side is more then, it switches ON the green light on North side and yellow light on East side and red light on South and West side for the prescribed time and then again check the traffic density.

IV. RESULTS AND DISCUSSION

The simulated result of various situations of the four way junction traffic signaling with the implemented system is shown in the following figures, to check the effectiveness and performance of the system.

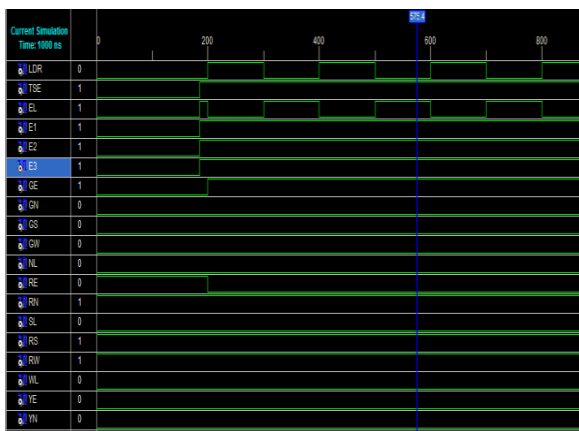

Fig. 4: Simulation results when more traffic on East

The above results in Fig.4 indicate that when there is no Sun light (LDR=0) and traffic on East (TSE=high) then street light on East will glow (EL=high). Along with this, if traffic density on East (DE=(E1=E2=E3)=high) is more then, Green light on East and Yellow light on South and Red light on West and North will glow for prescribed time.

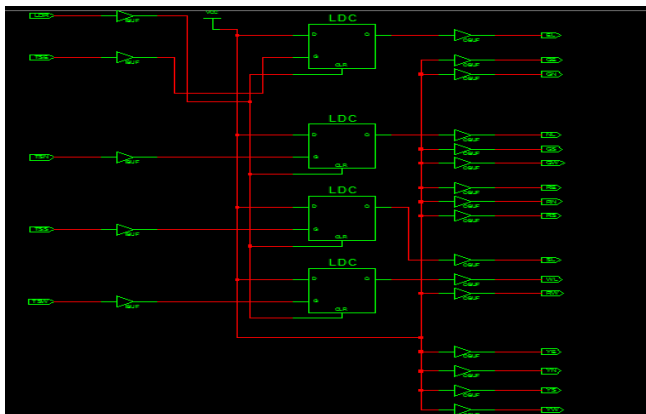

Fig. 5: Technology Schematic

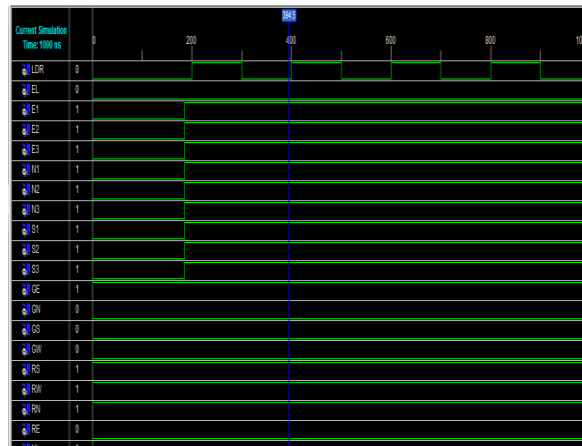

Fig. 6: Simulation results when traffic is equal on all sides

The results in Fig.6 indicate that when there is Sun light (LDR=1) and there is no traffic on streets. Along with this, (E1=E2=E3=S1=S2=S3=W1=W2=W3=N1=N2=N3=high) then green light on East and yellow light on South and red light on West and North will glow for prescribed time.

V. CONCLUSION

The design and verification of Automatic Street light and traffic control system is done successfully by using CPLD based system. The advantage of the present system is the utilization of solar energy in an efficient manner. It requires the initial cost only for designing and installation and not for utilization. Hence, such systems are very much useful for the government to reduce the utilization of conventional power (generated by hydraulic power stations). Therefore, such systems are once implemented on a large scale can bring significant reduction of the power consumption caused by street lights and traffic control lights. This initiative will help the government to save this energy and meet the domestic and industrial needs. It can overcome the drawback of conventional traffic controllers where, the traffic signaling is done in equal intervals of time but in the proposed system, with the capability of providing varying green cycle interval based on dynamic traffic load changes at every lane in a 4-way junction control.

REFERENCES

[1] Costa, M.A.D., Costa, G.H., dos Santos, A.S., Schuch, L. and Pinheiro, J.R. (2009), "A high efficiency autonomous street lighting system based on solar energy and LEDs", Brazilian PowerElectronics Conference (COBEP 2009), Bonito, 27 September-1 October, pp. 265-73.

[2] Caponetto, R., Dongola, G., Fortuna, L., Riscica, N. and Zufacchi, D. (2008), "Power consumption reduction in a remote controlled street lighting system", International Symposium on Power Electronics, Electrical Drives, Automation and Motion (SPEEDAM 2008), Ischia,une, pp. 428-33.

[3] Paul R. Marques and A. Scott McKnight "Evaluating Transdermal Alcohol Measuring Devices" DTNH22-02-D-95121, Pacific Institute for

Research and Evaluation 11720 Beltsville Drive, Suite 900, Calverton, MD 20705

[4] Farmer C. M. 2005. Relationships of Frontal Offset Crash Test Results to Real-World Driver Fatality Rates. *Traffic Injury Prevention*, 6, 31-37.

[5] R. Swift, C. Martin, L. Swette, A. LaConti and N. Kackley, "Studies on a Wearable, Electronic, Transdermal Alcohol Sensor," 16 *Alcohol. Clin. Exp. Res.* 721 (July/Aug. 1992)

[6]http://www.estreetlight.com/Documents/Homepage/Estreet%20Project%20Report%202005_157.pdf.

[7] John K. Pollard, Eric D. Nadler, Mary D. Stearns," Review of Technology to Prevent Alcohol-Impaired Crashes (TOPIC)", OMB No.0704-0188,U.S.Department of Transportation Research and Innovative Technology Administration Cambridge, MA02142.

[8]http://www.estreetlight.com/Documents/Homepage/Estreet%20Project%20Report%202005_157.Pdf.

[9] John K. Pollard, Eric D. Nadler, Mary D. Stearns," Review of Technology to Prevent Alcohol-Impaired Crashes (TOPIC)", OMB No.0704-0188,U.S.Department of transportation Research and Innovative Technology Administration.

[10] John M. Anderson. "First Electric Street Lamps" *IEEE Power Engineering Review*, pp.39-40, Mar. 2000.

[11] Illuminating Engineering Society of North America "IESNA RP-8-00" American National Standard Practice for Roadway Lighting, 2005.

[12] Gordon S. Smith and Peter Barss. "Unintentional Injuries in Developing Countries:The Epidemiology of a Neglected Problem" *Epidemiologic Reviews* - The Johns Hopkins University School of Hygiene and Public Health Vol.13,1991.

[13] John Klein. (2003, Apr) "Shoot-through in Synchronous Buck Converters." FairChild Semiconductor Application Note AN-6003 [Online]. Available: (http://www.fairchildsemi.com/an/N/AN_6003.pdf) [Apr 01, 2008].

[14] Rob McMonagle. The Environmental Attributes of Solar ContextInternet:<http://www.cansia.ca/downloads/report2006/C21.pdf> [Apr 06, 2008] , The Canadian Solar Industries Association, Jul 2006.

[15] Cree® XLamp® XR-E LED Data Sheet. Internet:<http://www.cree.com/products/pdf/XLamp7090XR-E.pdf>, Jan 2008 [Apr 06, 2008].

AUTHORS

First Author-



Mr. K. Manoj Kumar received his Bachelor of Technology in Electronics and Communication Engineering in Netaji Engineering College, Hyderabad, A.P., India in 2011. He is doing his research on CPLD . His areas of interests are doing VHDL based projects.

Email_address: karudagattu.manoj@gmail.com

Correspondence Author –karudagattu.manoj@gmail.com.

Contact on 08297494077.

Second Author-

Mr. N.Purandara babu received his Bachelor of Technology in Electronics and Communication Engineering in S.S.J Engineering College, Hyderabad, A.P., India in 2009. He is doing his research on CPLD . His areas of interests are doing VHDL based projects.

Email_address: puri.hyd@gmail.com

Contact on .09885464741

Third Author-

Mrs.M.Triveni received his Bachelor of Technology in Electronics and Communication Engineering in Audisankara Engineering College, Nellor, A.P., India in 2008. He is doing his research on CPLD . His areas of interests are doing VHDL based projects.

Email_address: mrudalatriveni@gmail.com

Contact on .09963125942

Fourth Author-

Mr. Ramesh Babu working as Assistant professor in AVR & SVR Engineering college, kurnool,A.P.