

CLUSTER BASED APPROACH: TO REDUCE THE ENERGY CONSUMPTION OF WIRELESS SENSOR NETWORKS

N Punitha ^{#1}, Dr.S Anandamurugan ^{#2}
 Department of Information Technology
 Kongu Engineering College
 Perundurai, Erode

npunitha23@gmail.com^{#1}
 samurugan@kongu.ac.in^{#2}

Abstract- The utilization of Wireless Sensor Networks (WSNs) to a full extend is limited by the limited energy constraints of the individual sensor nodes. Large part of the research in WSNs focuses on the development of energy efficient routing protocols. Energy usage is the determining factor in the performance of WSNs. Both the methods of data routing and transferring to the base station are very important because the sensor nodes run on battery power and the energy availability for each sensor node is limited. To maximize the lifetime of the sensor node, it is better to share the energy dissipated throughout the sensor network in order to reduce maintenance and enhance the overall system performance. The proposed Cluster based approach is combined with Ladder Diffusion (LD) and Ant Colony Optimization (ACO) to reduce the power consumption and to solve transmission routing problems in wireless sensor networks. The LD algorithm is employed to route paths for data relay and transmission in wireless sensor networks and it reduces power consumption, processing time to build the routing table. Moreover, to ensure the safety and reliability of data transmission, LD-ACO algorithm provides backup routes to avoid wasted power and processing time when rebuilding the routing table in case part of sensor nodes are missing.

Keywords- Cluster Head; Ant colony Optimization; AODV; Ladder Diffusion; Grade value; Ladder Table; Ladder creating Package

I. INTRODUCTION

A WSN consists of large number of autonomous sensor nodes, in which each and every sensor is connected with one or more sensor nodes without the use of any wires (i.e.) connected via wireless. The design of WSNs depends on required application. Environmental monitoring is an application where a region is sensed by numerous sensor nodes and the sensed data are gathered at the base station (a sink) where remaining process can be carried out. The sensor nodes for such applications are usually designed to work in conditions where it cannot be possible to recharge or refill the battery of those nodes. Hence energy is very precious resource for sensor nodes. This limitation makes the design of routing protocols a challenging task. The WSN is built of "sensor nodes" – from a few to some hundreds or thousands, where every node is connected to one or several sensors. Each sensor node have several parts such as a radio transceiver consisting internal antenna and an external antenna, an electronic circuit, a microcontroller and an energy source usually a battery.

Actually the nodes are referred as ‘Sensor’ because these nodes are equipped with smart sensors. A sensor node is a device that converts a sensed characteristic like temperature, vibrations, pressure into a form recognize by the users. A wireless sensor networks node has less mobility compared to ad-hoc networks. So mobility in case of ad-hoc is more. In wireless sensor network data are requested depending upon certain physical quantity.

The main components of a sensor node as seen from the Fig.2 are microcontroller, transceiver, external memory, power source and one or more sensors. Microcontroller processes data and controls the functionality of other components in the sensor node.

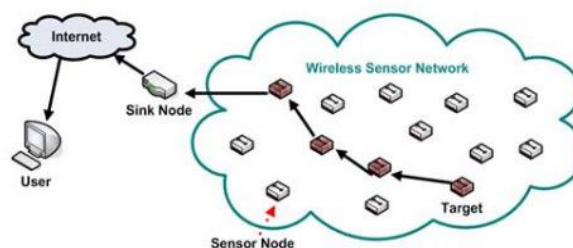

Fig.1 Wireless Sensor Network

Sensors are used to sense the data from the physical environment, memory is for storage, and a transceiver is used for data transmission.

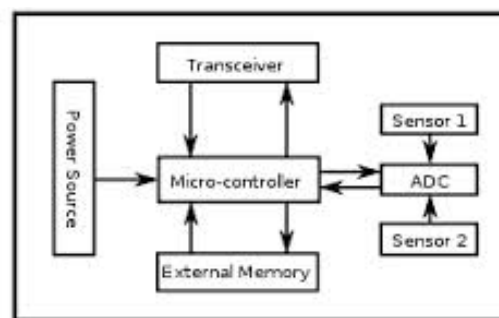

Fig.2 Architecture of Sensor Node

II. PROBLEM DEFINITION

Wireless sensor networks consist of many sensor nodes that contain environmental sensing devices for movement, temperature, humidity, exhaust gas, and so on, which are distributed over an area to measure various characteristics of that region. Each sensor node also has limited wireless computational power to process and transfer the sensing live data to the base station or data collection center.

In general, each sensor node has a low level of power, and its battery power cannot be replenished. If the energy of a sensor node is exhausted, wireless sensor network leaks will appear, and failure nodes will not relay data to the other nodes during transmission processing. Thus, other sensor nodes will be increasingly burdened with transmission processing. Given these issues, energy consumption in wireless sensor networks is an important research issue.

III. PROPOSED WORK

A. Cluster Based Approach

The nodes in the environment will form clusters. In every cluster, a node will act as a cluster head and the all the remaining node will be cluster members.

1) Cluster formation

Cluster formation takes place by exchanging the HELLO packets between the nodes. The HELLO message contains the information about node's state, its neighbour table, and its cluster adjacency table. The HELLO packets are exchanged periodically to maintain the neighbour table. The fields in the neighbour table are neighbour status and the link status. The value of neighbour status will be C_HEAD (cluster head), C_MEMBER (cluster member) and C_UNDECIDED (cluster undecided). The link status will hold values such as unidirectional and bidirectional. The HELLO message format is shown in the Table.1.

2) Cluster Head Election

The Cluster head can be selected by calculating net weight for each node in the cluster by using Equation (1),

$$W_V = W_1 \Delta_V + W_2 D_V + W_3 P_V \quad (1)$$

Where,

W_V represents the net weight of node V.

Δ_V represents the total number of nodes within its transmission range of node V.

D_V represents the sum of distances of all its neighbours.

P_V implies how much battery power has been consumed.

Table.1 HELLO message format

Node ID	Node Status	
Neighbour ID	Neighbour Status	Link Status
...
Adjacent Cluster ID		
...		

The net weight is calculated by every node and it is exchanged with all its neighbour nodes and each node will maintain this list of neighbours along with their net weight. The node having lowest net weight is considered as cluster head. The exchange of net weight with the neighbour node is done using HELLO packet transmission periodically.

The cluster adjacency table and neighbour table are exchanged between the cluster heads by using HELLO packets. For the Fig.3, Table.2 shows the cluster adjacency table for node 4 and Table.3 shows the neighbour table for node 2.

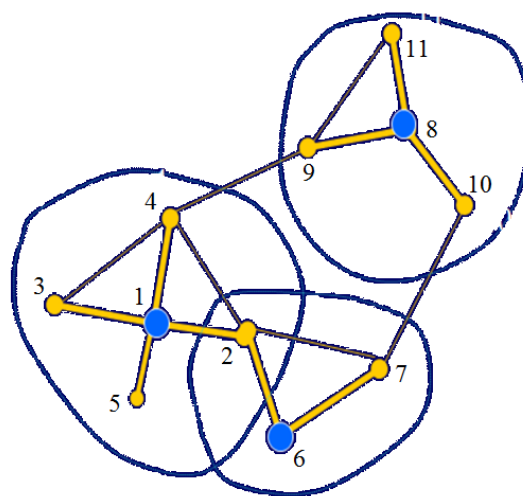

Fig.3 Cluster Formation

Table.2 Cluster Adjacency table for node 4

Adjacent Cluster ID	Gateway
8	9
6	2

B. Cluster based Ladder Diffusion- Ant Colony Optimization (CLD-ACO)

The energy efficiency in WSNs can be achieved by integrating Cluster Based Approach along with LD-ACO (Ladder Diffusion - Ant Colony Optimization) algorithms. Therefore to enhance the network lifetime of WSN, ladder diffusion phase is applied to whole WSN. Grade values for all the Cluster Heads

(CHs) is achieved by applying LD algorithm, after obtaining grade values ACO algorithm is applied to find shortest best optimal path.

Table.3 Neighbour table for node 2

Nbr ID	Nbr Status	Link Status
7	C_MEMBER	Bi-directional
6	C_HEAD	Bi-directional
4	C_MEMBER	Bi-directional
1	C_HEAD	Bi-directional

C. Ladder Diffusion (LD) Algorithm

The ladder diffusion algorithm integrated with ACO is used in order to minimize power consumption. This algorithm is used to identify routes from sensor nodes to the sink node and avoid the generation of circle routes using the ladder diffusion process. It creates the ladder table in all CHs by issuing the ladder create packet that is created from the sink node.

1) Ladder Diffusion Phase

The process of ladder diffusion is as follows. Consider center node as sink node and surrounding nodes as sensor (source) nodes. From the sink node, ladder-x package

will be broadcasted towards the edge of the environment. When receiving the ladder-x package, the CHs stores the grade value of itself and maintains a ladder table. Grade-1 CHs transmit data to the sink node by requiring only one hop. Likewise, Grade-2 sensor nodes transmit data to the sink node by requiring two hops and so on. First, the sink node broadcasts the ladder-x package with a value of grade as one, as shown in Fig.4. The CHs ‘‘b’’ and ‘‘c’’ receive a ladder-x package with a grade value of one from sink node ‘‘a’’. Then CHs ‘‘b’’ and ‘‘c’’ increase the grade value of the ladder-x package to two and broadcast the modified ladder-x package. In Fig.5, the CHs ‘‘d’’ and ‘‘e’’ receive ladder-x packages with a grade value of two from nodes ‘‘b’’ and ‘‘c’’. The CHs ‘‘d’’ and ‘‘e’’ increase the grade value of the ladder-x package to three and broadcast the modified package again towards the edge of the environment.

A cluster head discards the package if the grade value of currently received package is greater than already recorded value in the ladder table for that cluster head. Moreover, if many CHs simultaneously broadcast ladder-x packages with the same grade value, the sensor nodes receive and record the packages in their respective ladder tables as back-up nodes.

The sensor nodes can transmit data depending on the ladder table already created, with the data transfer routes going from high grade value to low grade value. If a CH has two candidate nodes in the ladder table, then both the node can be selected as its relay node; hence that CH has two routes that can be used to transmit data to sink node ‘‘a’’.

After the LD process, each CH record the grade value in the ladder table. The CH can record more than one node as relay nodes in the ladder table when receiving the ladder-x package with a grade value less than itself. Hence there are many back-up relay nodes that can be used to transmit data to the sink node.

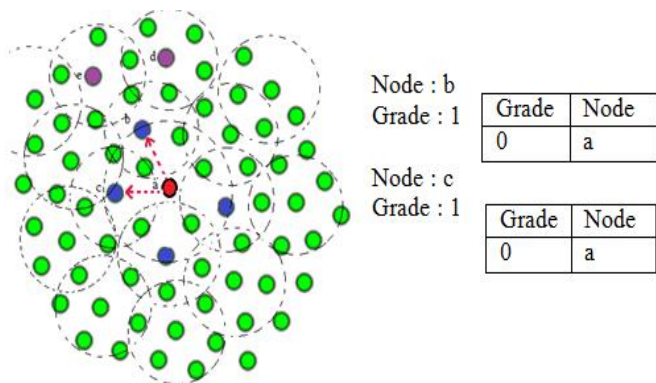

Fig.4 Ladder-1 Package Transmission

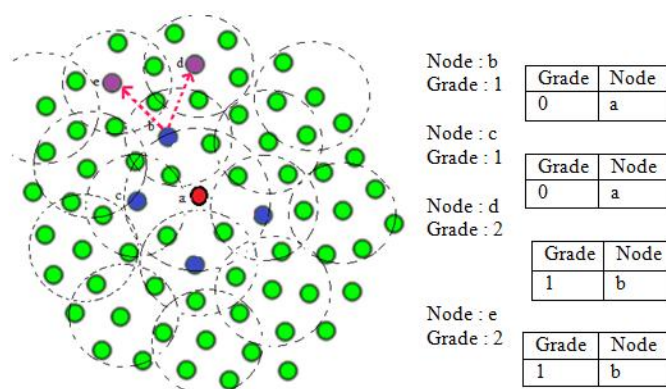

Fig.5 Ladder-2 package Transmission

D. Ant Colony Optimization

The Ant Colony Optimization algorithm (ACO) is a probabilistic technique for solving computational problems which can be reduced by finding good paths through graphs. The algorithm aims to find optimal path in a graph, based on behaviour of ants finding a path between their colony and source of food. Ants travel in random path to search the food and after finding food, it returns back to colony by laying down the pheromone trails. Over time, however, the pheromone trails have to evaporate in order to reduce its attractive strength. The more time it takes for an ant to march the path, the more time the pheromones will evaporate.

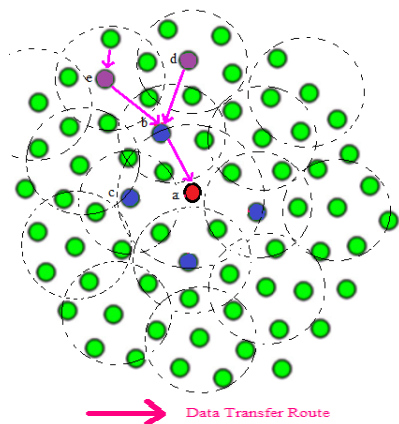

Fig.6 Data transfer route of sensor nodes

Thus, the time taken for an ant to march over a path is directly proportional to pheromone trail evaporation. A short path gets marched more frequently, and thus the pheromone density will be higher on shorter paths compared to longer ones. Pheromone evaporation has advantage of avoiding the convergence to optimal solution. If in case there were no evaporation, the paths chosen by the first ants would tend to be excessively attractive to the following

ones. In that case, searching the solution space would be limited.

Thus, when one ant finds a good (i.e., short) path from the colony to a food source. Other ants will follow that path, and positive feedback leads to all the ants follow a same path. The LD algorithm integrates ACO to achieve the lowest level of power consumption to select suitable routes and also the energy level of each sensor node can be balanced as routing can be chosen to include different relay nodes. ACO is used to solve problems related to choosing routes. The route choosing phase involves selecting and constructing the routes from sensor nodes to the sink node.

1) Initialization

Suppose the route from sensor node “a” to sink node “s” is constructed during the ladder diffusion phase as the route shown in Fig.6.

The initialization parameter configuration is given as follows:

- i. Initialize the starting point for the ants: The starting point for all ants is sensor node “a,” and the routing path is from node “a” to sink node “s”.
- ii. Initialize the selection rate of the routing path for artificial ants (q0), environment pheromone (s0), and pheromone evaporation rate (a): The value of these parameters ranges from zero to one.

2) Fitness function

The fitness function calculates power consumption by sensor nodes while transmitting data and to decide how much pheromone must remain. Eventually if the data transfer rate is increased, energy consumption will increase. The parameter n is usually set at 2 because energy consumption is proportional to the square of distance. The parameters r, α1, and α2 are constant values.

$$P_{(i,j)} = r (\alpha_1 + \alpha_2 d_{(i,j)}^n) + N_j \tag{2}$$

where,

- r the data transfer rate of sensor nodes;
- $d_{(i,j)}$ the Euclidean distance between node i and node j;
- $P_{(i,j)}$ the energy consumption after node i transmits data to node j;
- α_1 the distance-independent parameter;
- α_2 the distance-dependent parameter;
- N_j the consumptive energy of node j.

3) Walking phase

Artificial ants select the routing path using a random parameters q and q_0 where, q is a random number uniformly distributed in [0, 1], and q_0 is a parameter ($0 \leq q_0 \leq 1$). There were two cases:

Case 1: If $q > q_0$, then the “exploring rule” is used.

The “exploring rule” calculates the usable energy of all back-up nodes using Equation (2) and then calculates the rate of selection for all back-up nodes using Equation (3)

$$U_k(i, j) = \frac{\tau(i, j) \cdot [P_{(i,j)}^{-1}]^\beta}{\sum_{J(i)} [\tau(i, j)] \cdot [P_{(i,j)}^{-1}]^\beta} \quad (3)$$

Where,

- $U_k(i, j)$ is the probability that ant k on node i chooses to move to node j;
- $J(i)$ the set of back-up nodes for node i;
- $\tau(i, j)$ the pheromone between node i and node j;
- $P_{(i,j)}$ the energy consumption of node i and node j;
- β the evaluation parameter of pheromone versus energy consumption.

Case 2: Otherwise, the “using rule” is employed.

The “using rule” selects the route which have more remaining pheromone. Equation (4) is used by an ant to choose the next node j from the currently positioned node i.

$$\begin{cases} \arg \max_{j \in J(i)} \tau(i, j) & , \text{ if } q \leq q_0 \\ S & , \text{ if } q > q_0 \end{cases} \quad (4)$$

4) Local updating

The pheromone of the route that the artificial ant selects is updated using Equation (2) and Equation (5)

$$\tau(i, j) \leftarrow (1 - \rho) \cdot \tau(i, j) + \rho \cdot (n * (r, s))^{-1} \quad (5)$$

Where, n is the nth sensor node on the route.

5) Global updating

The ACO algorithm can record the optimum route and update the new optimum route and pheromone for all nodes along the route if the energy consumption of the new route is less than that of the old route. In addition, ACO updates the pheromone levels for sensor nodes that are included in the intersection set of the two routes if the new route is not an optimum route. This method of updating is shown in Equation (6)

$$\tau(i, j) \leftarrow (1 - \alpha) \cdot \tau(i, j) + \alpha \cdot \sum_{s=1}^{m-1} (nP_{(i,j)}(r, s))^{-1} \quad (6)$$

In Equation (6), m is the intersection set of sensor nodes on this route and on the optimum route.

IV.SIMULATION

In this section, experiment and simulation results are described. The performance of CLD-ACO and LD-ACO is compared in terms of energy efficiency and throughput. The experiment is designed by varying the number of nodes, which is defined with 1000 X 1000 dimensions. The transmission range of the nodes was set to 15 units. Sensor nodes are distributed uniformly over the space in each of these simulations. The node which is in center is the sink node. All the remaining nodes are termed as sensor (source) nodes which are intended to transmit data to sink node. In the simulation, 1000 data packages are exchanged between random source/sink pairs. In the below mentioned experiments, the parameters are set to the following values: Data transfer rate (r) = 0.3, Environment pheromone = 1, pheromone evaporation rate = 0.01, initial energy = 100 in Joules, receiving power = 2.0, transmitting power = 2.0.

A) Nodes vs. Energy Consumption

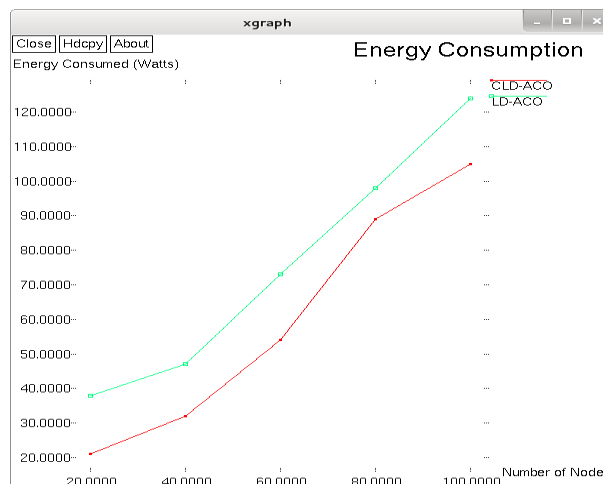

Fig.7 Nodes vs. Energy Consumption

Energy Consumption refers to amount of energy consumed in a process or system. Energy Consumption will be high in LD-ACO when compared to CLD-ACO protocols. Variation in Energy consumption is shown in the Fig.7.

B) Nodes vs. Throughput

Throughput is usually measured in bits per second (bits or bytes per second), and sometimes in data packets per second or data packets per time slot. Throughput will be high for CLD-ACO when compared to LD-ACO protocol. Throughput variation is shown in the Fig.8.

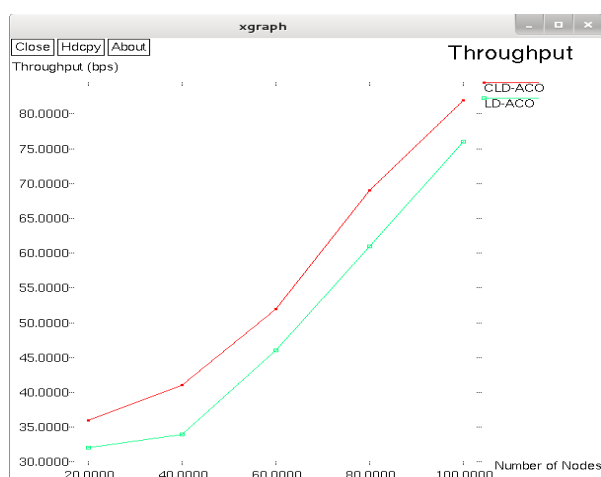

Fig.8 Nodes vs. Throughput

C) Nodes Vs. Packet Delivery Ratio

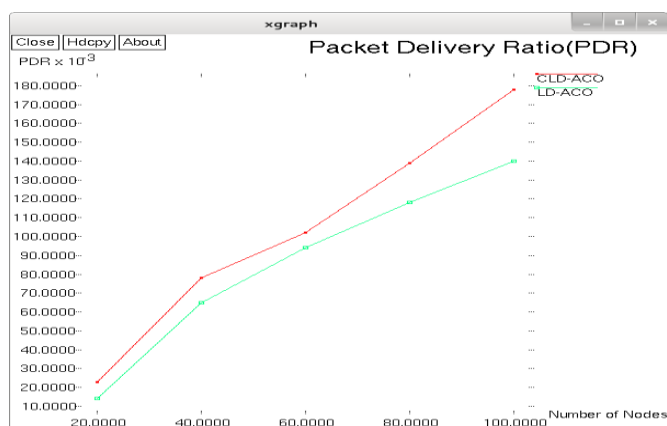

Fig.9.Nodes vs. Packet Delivery Ratio

Packet delivery ratio(PDR) is the ratio of the number of delivered data packet to the destination. This illustrates the level of delivered data to the destination.

$$PDR = \frac{\sum \text{Number of packet receive}}{\sum \text{Number of packet send}}$$

Packet Delivery Ratio will also be high for CLD-ACO when compared to LD-ACO protocol. PDR variation is shown in the Fig.9.

The performance of Quality of Service (QoS) is analysed by taking energy consumption and throughput parameters into account. From the obtained results, the performance of QoS is improved by using CLD-ACO. The simulation results shows that the proposed CLD-ACO algorithms consumes less energy for packets relay required by a single node compared to LD-ACO algorithm. The proposed method results in better efficiency than traditional LD-ACO. It reduces the maximum energy consumption of sensor nodes by 12% as compared to LD-ACO. And also CLD-ACO have better throughput and PDR than LD-ACO.

V.CONCLUSION

The system measures the QoS by using cluster based approach with LD-ACO mechanisms in Wireless Sensor Networks. The performance measurement of CLD-ACO and LD-ACO protocols is taken. The result shows that CLD-ACO protocol is having improved performance than LD-ACO protocols in terms of the parameters like Energy Consumption, Throughput. Further analysis can be made by having some other optimization instead of Ant Colony Optimization to conserve the energy of the network and combining some other energy efficient mechanisms with CLD-ACO.

VI.REFERENCES

- [1] C.E. Perkins, E. Royer, "Ad hoc on-demand distance vector routing", in: Proceedings of IEEE WMCSA, pp. 90-100, 1999.
- [2] Kartheek Srungaram, Dr. MHM Krishna Prasad, "Enhanced cluster based routing protocol for manets", Information Sciences Vol.13, pp. 32-39, 2009.
- [3] M. Hussaini, H. Bello-Salau, A. F. Salami "Enhanced Clustering Routing Protocol for Power-Efficient Gathering in Wireless Sensor Network", International Journal of Communication Networks and Information Security, Vol. 4, No. 1, 2012.
- [4] Jiguo Yu, Yingying Qi, Guanghui Wang, Xin Gu, "A cluster-based routing protocol for wireless sensor networks with nonuniform node distribution", Information Sciences Vol.66, pp. 54-61, 2012.
- [5] E.M. Royer, C.-K. Toh, "A review of current routing protocols for ad-hoc mobile networks", IEEE Personal Communications Vol.6, pp. 46-55, 1999.

- [6] M. Dorigo, L.M. Gambardella, "Ant colony system: a cooperative learning approach to the traveling salesman problem", IEEE Computational Intelligence Society Vol.1, pp. 53–66, 1997.
- [7] M. Dorigo, V. Maniezzo, A. Colomi, "The ant system: optimization by a colony of cooperating agents", IEEE Systems, Man, and Cybernetics Society Vol.26, pp. 29–41, 2008.
- [8] Rajiv Misra, Chittaranjan Mandal, "Ant-aggregation: ant colony algorithm for optimal data aggregation in wireless sensor networks", IFIP International Conference on Wireless and Optical Communications Networks, pp.56-71, 2006.