

MATLAB/SIMULINK MODELING OF GRID CONNECTED PV SYSTEM WITH MAXIMUM POWER POINT TRACKING

K.Sheshu Kumar

Assistant Professor

Department of Electrical and Electronics Engineering
Vignan Institute of Technology and Science, Vignan Hills
Deshmukhi Village, Pochampally Mandal, Nalgonda District-508284

B.Naga Swarna

Master of Technology In Power Electronics & Electrical Drives
Department of Electrical and Electronics Engineering
Vignan Institute of Technology and Science, Vignan Hills
Deshmukhi Village, Pochampally Mandal, Nalgonda District-508284

Shankar. B

Master of Technology In Power Electronics & Electrical Drives
Department of Electrical and Electronics Engineering
Vignan Institute of Technology and Science, Vignan Hills
Deshmukhi Village, Pochampally Mandal, Nalgonda District-508284

Abstract- Nowadays, photovoltaic (PV) systems are used as energy source in many cases. Most commonly applied PV systems can be found in remote and rural areas where no public grid is available. Maximum Power Point Tracking (MPPT) for photovoltaic (PV) systems maximizes the power that can be transferred from the PV system to an electrical system. This paper describes the study of the verification of characteristic equation for the output current generated by a solar panel. The characteristic equation is simulated by using MATLAB/Simulink. Many factors that affect the performance of the solar energy tracking system need to be considered profoundly for the complete & effective utilization of the available energy. This work deals with the study of tracking the position of the sun and positioning the solar panel to operate at the maximum power point.

Index Terms: Photovoltaic system (PV), Voltage Source Inverter(VSI), Grid, Maximum Power Pointing tracking (MPPT).

I. Introduction

Photovoltaic power generation systems have intensively been investigated as an environment-friendly technology since 1970s because of their advantages of infinite energy resources and no CO₂ emission. However, low efficiency and high cost per unit output power are the biggest problem of the systems; which prevents the systems from being extensively used so far. A technique to utilize effectively the photovoltaic is known as a maximum-power-point tracking (MPPT) method, which makes it possible to acquire as much power as possible from the photovoltaic. Since an electric characteristic of the output power to the operating

voltage or current has a convex property, there exists only one optimum operating point on the power-voltage (or current) curve.

In photovoltaic systems, solar energy is converted into electrical energy by photovoltaic (PV) arrays. PV arrays are very popular since they are clean, inexhaustible and require little maintenance. Photovoltaic systems require interfacing power converters between the PV arrays and the load.

A typical small photovoltaic power system (off-grid) can contain the following components: solar PV array, with a number of series/parallel interconnected solar modules and protection elements, a DC/DC converter, a DC/AC inverter and a control system.

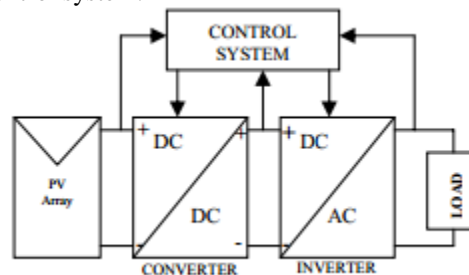

Fig.1. Basic structure photovoltaic system

This target of control system is that the PV array will maximize the electrical power with a given irradiance. The control should guarantee that the dc power will be transformed with high efficiency to the load. In order to

archive the maximum power point (MPP) of the PV array, it is necessary maintain it at their optimum point operating. The MPP varies with the solar radiation and the temperature. The characteristic curves specify a unique operating point at which maximum possible power is delivered. At the MPP, the PV system operates at its highest efficiency.

The MPPT is a method to let the controller operate at the above-mentioned optimum operating point. There have been various kinds of MPPT methods reported and the most common technique of them is a hill-climbing method, which seeks the optimum operating point by changing the operating voltage or current until the power becomes the maximum. Therefore, this method essentially requires power calculation using both the voltage sensor and the current sensor. On the other hand, several other proposals have been made, which are completely different from the conventional hill-climbing based MPPT methods. Some of them determine the optimum operating current on the basis of a short-current detection of the photovoltaic. These methods utilize a property of the photovoltaic of which optimum operating current is proportional to its short current. One of them has a monitor photovoltaic cell to detect its short-current and another has a switch that intermittently and directly shorts the main photovoltaic. These methods do not require the voltage sensor but the monitor photovoltaic or the short-circuit switch must be implemented in the power converter.

As described above, several sensor and/or additional equipment are indispensable to achieve MPPT in the conventional system, which makes the system configuration considerably complicated.

II. ABOUT PHOTO VOLTAIC SYSTEMS AND MPPT ALGORITHM

A. PV System:

A photovoltaic (PV) system directly converts sunlight into electricity. The basic device of a PV system is the PV cell. Cells may be grouped to form panels or arrays. The voltage and current available at the terminals of a PV device may directly feed small loads such as lighting systems and dc motors. [7] A photovoltaic cell is basically a semiconductor diode whose *p-n* junction is exposed to light. Photovoltaic cells are made of several types of semiconductors using different manufacturing processes. The incidence of light on the cell generates charge carriers that originate an electric current if the cell is short circuited.

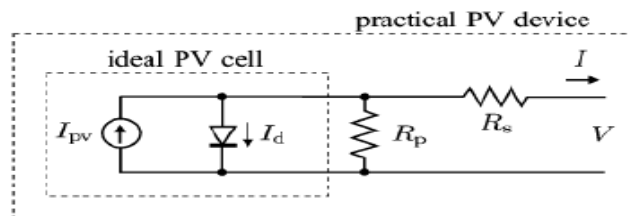

Fig. 2: Equivalent Circuit of a PV Device including the series and parallel Resistances.

The equivalent circuit of PV cell is shown in Fig. 2. In the above diagram the PV cell is represented by a current source in parallel with diode. R_s and R_p represent series and parallel resistance respectively. The output current and voltage from PV cell are represented by I and V

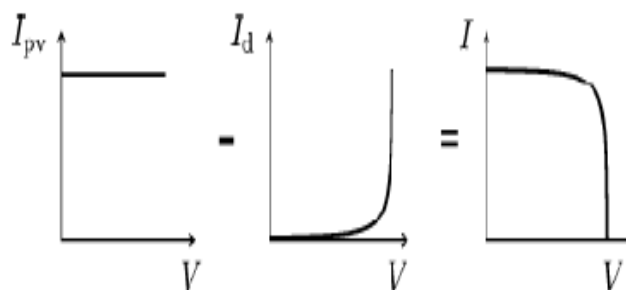

Fig. 3. V-I Characteristic of PV Cell

The I-V Characteristics of PV cell [7] is shown in Fig.3. The net cell current I is composed of the light-generated current I_{pv} and the diode current I_d

$$I = I_{pv} - I_d \tag{1}$$

Where

$$I_d = I_0 * \exp^{qV/a kT}$$

I_0 = leakage current of the diode

q = electron charge

k = Boltzmann constant

T = temperature of pn junction

a = diode ideality constant

The basic equation (1) of the pv cell does not represent the I-V characteristic of a practical PV array. Practical arrays are composed of several connected PV cells and the observation of the characteristic at the terminals of the PV array requires the inclusion of additional parameters to the basic equation.

$$I = I_{pv} - \left[\exp \left(V + \frac{R_{si}}{V_{ta}} \right) - 1 \right] - \quad (2)$$

Where

$$V_t = N_s k T / q$$

Is the thermal voltage of the array with N_s cells connected in series. Cells connected in series provide greater output voltages. The I-V characteristic of a practical PV cell with maximum power point (MPP), Short circuit current (I_{sc}) and Open circuit voltage (V_{oc}) is shown in Fig. 4. The MPP represents the point at which maximum power is obtained.

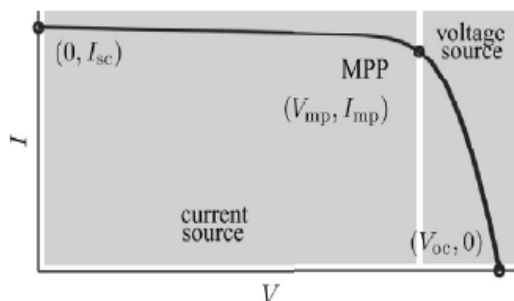

Fig. 4. I-V Characteristic of Practical PV Module

V_{mp} and I_{mp} are voltage and current at MPP respectively. The output from PV cell is not the same throughout the day; it varies with varying temperature and insolation (amount of radiation). Hence with varying temperature and insolation maximum power should be tracked so as to achieve the efficient operation of PV system.

B. MPPT Algorithm:

To maximize a photovoltaic (PV) system's output power, continuously tracking the maximum power point (MPP) of the system is necessary. **The MPP depends on irradiance conditions, the panel's temperature, and the load connected.** Maximum power point tracking (MPPT) algorithms provide the theoretical means to achieve the MPP of solar panels; these algorithms can be realized in many different forms of hardware and software. PV systems that lack MPPT *rarely* operate at the most efficient, MPP. This is why the rated power of the solar panel is almost never realized when connecting a load.

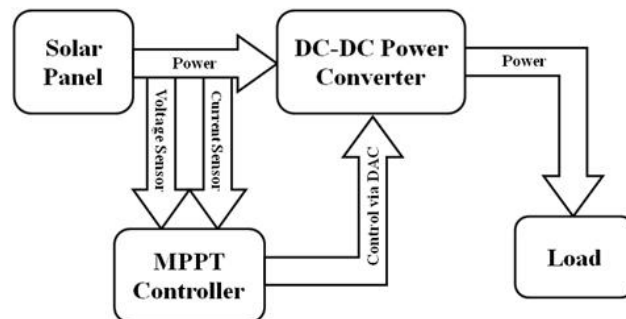

fig 5.MPPT in PV system.

Various algorithms may perform MPPT. Important factors to consider when choosing a technique to perform MPPT are the ability of an algorithm to detect multiple maxima, costs, and convergence speed.

The irradiance levels at different points on a solar panel's surface tend to vary. This variation leads to multiple local maxima power points in one system. The efficiency and complexity of an algorithm determine if the true maximum power point or a local maximum power point is calculated. In the latter case, the maximum electrical power is not extracted from the solar panel.

MPPT algorithms are necessary in PV applications because the MPP of a solar panel varies with the irradiation and temperature, so the use of MPPT algorithms is required in order to obtain the maximum power from a solar array. There are many MPPT techniques in MPPT Algorithm, Mostly We are using perturb and observation method.

The P&O algorithm is also called "hill-climbing", but both names refer to the same algorithm depending on how it is implemented. Hill-climbing involves a perturbation on the duty cycle of the power converter and P&O a perturbation in the operating voltage of the DC link between the PV array and the power converter. In the case of the Hill-climbing, perturbing the duty cycle of the power converter implies modifying the voltage of the DC link between the PV array and the power converter, so both names refer to the same technique. In this method, the sign of the last perturbation and the sign of the last increment in the power are used to decide what the next perturbation should be. If there is an increment in the power, the perturbation should be kept in the same direction and if the power decreases, then the next perturbation should be in the opposite direction. Based on these facts, the algorithm is implemented. The process is repeated until the MPP is reached. Then the operating point oscillates around the MPP. This problem is common also to the In Cond method, as was mention earlier. A scheme of the algorithm is shown in Fig. 6.

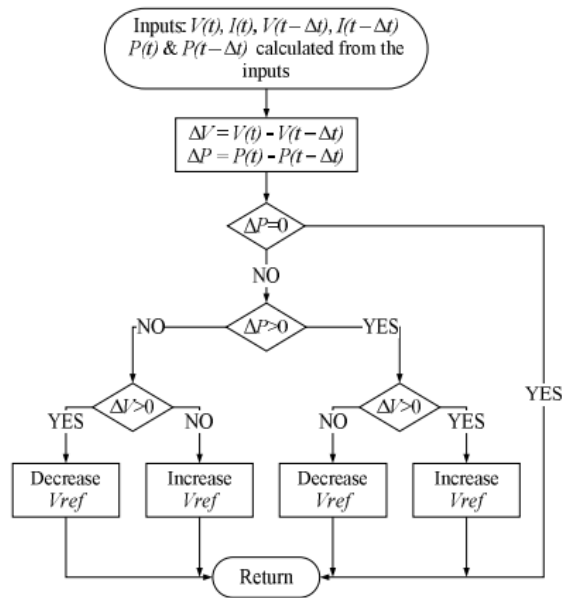

Fig. 6. The flowchart of the P&O Algorithm.

III. CHARACTERISTIC EQUATIONS

The characteristic equation is the output current produced by a solar cell viz. as follows

$$I = I_L - I_0 \left[\exp \left\{ \frac{q(V + IR_s)}{A_p K T} \right\} - 1 \right] - \left[\frac{V + IR_s}{R_{sh}} \right] \quad (3)$$

Where, Photo generated current (I_L) = 2.0034 A, saturation current of PV array (I_0) = 9195.08×10^{-12} A, ideality factor (A) = 1.2, series resistance (R_s) = 0.001 Ω , internal shunt resistance (R_{sh}) = 100 Ω , PV cell temperature (T_c) = 300 $^\circ$ K

The values of I_{or} , I_0 , I_L are calculated as

$$I_{or} = I_{sc} / \left(\exp \left[\frac{qV_{oc}}{N_s K A T_c} \right] - 1 \right) \quad (4)$$

Where,
VOC (Open circuit voltage of a PV array) = 0.596 V

$$I_0 = I_{or} \left(\frac{T_c}{T_r} \right)^3 \exp \left[\frac{(q EGO)}{A_p K} \left(\frac{1}{T_r} - \frac{1}{T_c} \right) \right] \quad (5)$$

Where,

Reference temperature (T_r) = 301.18 $^\circ$ K, energy band gap for silicon (EGO) = 1.1 eV

$$I_L = \left[I_{sc} + K_t (T_c - 298) \right] \lambda / 1000 \quad (6)$$

Where,
Short circuit current of a PV array (I_{sc}) = 2.00 A, short circuit current temperature coefficient at $I_{scr}(Kt)$ = 0.0017A/0C.

IV. TRACKING THE POSITION OF THE SUN

For a solar panel to be at the MPP all the time, it has to be exactly perpendicular to the incident rays of sun. This can be inferred from the equation for the equivalent flux falling on the surface as follows

$$I = I_{bn} \cos \theta \quad (7)$$

Where,

θ = angle between the incident beam of flux & normal to the solar panel

I_{bn} = incident radiation

The position of the sun changes at a fixed rate which is the speed of rotation of the earth. The position of the sun at a given time on a particular day can be determined based on two factors, namely Azimuth and Elevation. An Azimuth is the angle from a reference vector in a reference plane to a second vector in the same plane, pointing toward, (but not necessarily meeting), something of interest. In other words, the azimuth angle is the compass bearing, relative to true (geographic) north, of a point on the horizon directly beneath an observed object. The elevation angle, also called the altitude, of an observed object is determined by first finding the compass bearing on the horizon relative to true north, and then measuring the angle between that point and the object, from the reference frame of the observer. The concepts of azimuth and elevation are well explained in figure 4.

The following formula can also be used to approximate the solar azimuth angle, however because this formula utilizes cosine, the azimuth angle will always be positive, and therefore, should be interpreted as the angle east of south when the hour angle, h , is negative (morning) and the angle west of south when the hour angle, h , is positive. The elevation is given by the equation

$$\sin \theta_s = \cosh \cos \delta \cos \phi + \sin \delta \sin \phi \quad (8)$$

When the solar panel has to be rotated on two axes, both the elevation and azimuth have to be considered. Here, initially the plane is given an elevation with the horizontal and then the position of the sun is tracked by the value of θ obtained from the equation given below

$$\cos \gamma = \left[\frac{\cosh \cos \delta \sin \phi - \sin \delta \cos \phi}{\cos \theta_s} \right] \quad (9)$$

$$\begin{aligned} \cos \theta &= \sin \phi (\sin \delta \cos \beta + \cos \delta \cos \gamma \cos \omega \sin \beta) \\ &+ \cos \phi (\cos \delta \cos \omega \cos \beta - \sin \delta \cos \gamma \sin \beta) \\ &+ \cos \delta \sin \omega \sin \gamma \sin \beta \end{aligned} \quad (10)$$

Where, β is the angle of the plane (PV array) with respect to the horizontal, γ is azimuth, ω or h is the hour angle (150 per hour: positive in morning and negative in

afternoon), Φ is the Latitude, θ_s is the Elevation and δ is the declination in degrees which is given by

$$\delta = 23.45 \sin[360(284 + n)/365] \quad (11)$$

(Where 'n' is the day of the year)

The angle θ is called the zenith angle when the angle made by the plane (i.e. solar panel) with the horizontal is zero (i.e. $\beta=0$) and can be calculated from the angle of elevation as follows:

$$\text{Zenith angle} = 90^\circ - \text{elevation} \quad (12)$$

IV. MATLAB/SIMULINK MODELLING AND SIMULATION RESULTS

Simulink, developed by The Math Works, is a commercial tool for modeling, simulating and analyzing multi domain dynamic systems. Here the simulation is carried out by two cases 1. Single phase PV proposed system applied to grid. 2. Three phase PV proposed system applied to grid.

Case 1: Single phase PV proposed system applied to grid

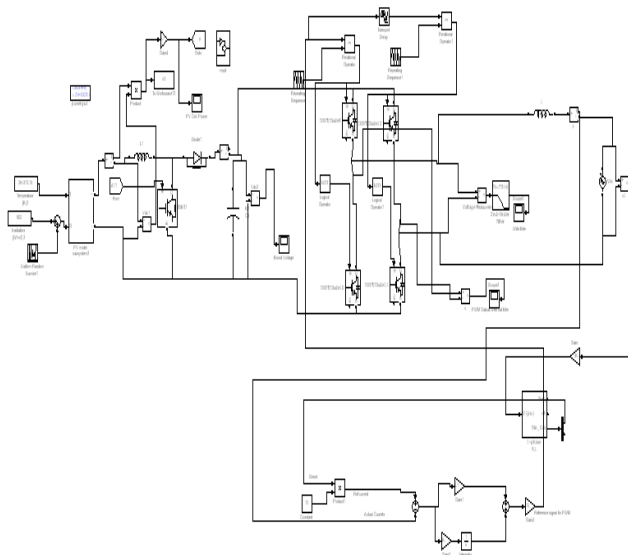

Fig.7. Matlab/Simulink model of Single phase PV proposed system applied to grid

As above Fig.7. Shows the Matlab/Simulink model of Single phase PV proposed system applied to grid.

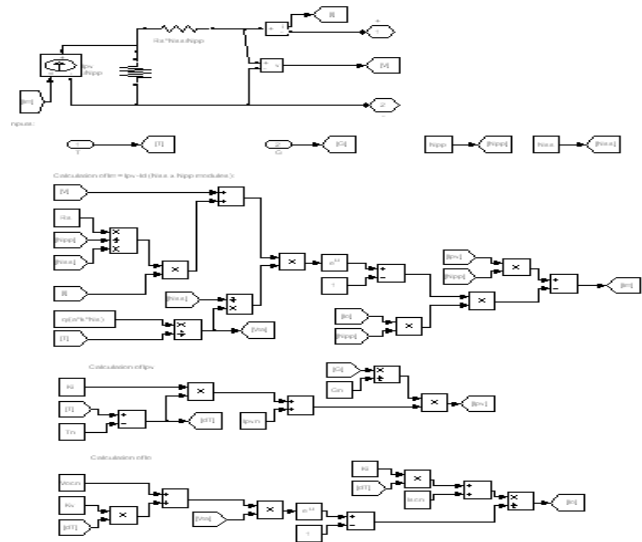

Fig.8. Matlab/Simulink model of proposed PV system

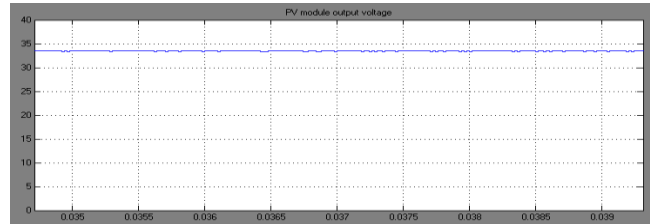

Fig. 9 Shows the output voltage of proposed PV system.

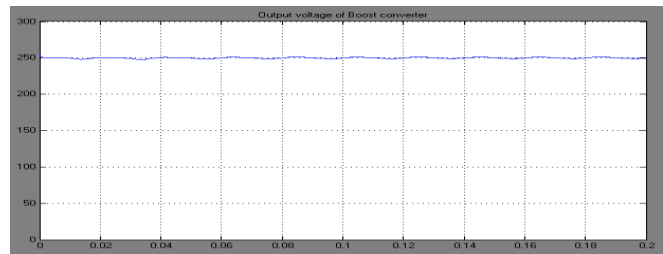

Fig .10.shows the output voltage of boost converter with PV proposed system

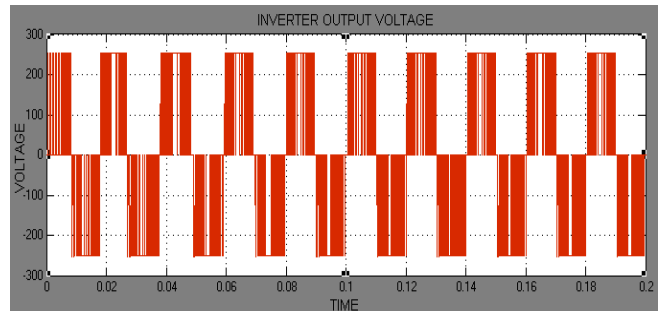

Fig.11. Output voltage of inverter without filter

Fig.11. Shows the Output voltage of inverter without filter, with PV proposed system.

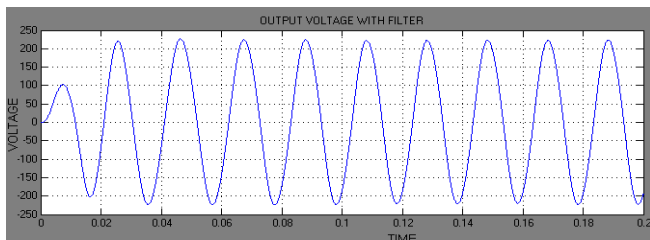

Fig.12. Output voltage of inverter with filter

Fig.12. Shows the Output voltage of inverter with filter, with PV proposed system. Here we are using normally second order filter for getting sinusoidal waveform instead of square wave form.

Case 2: Three phase PV proposed system applied to grid:

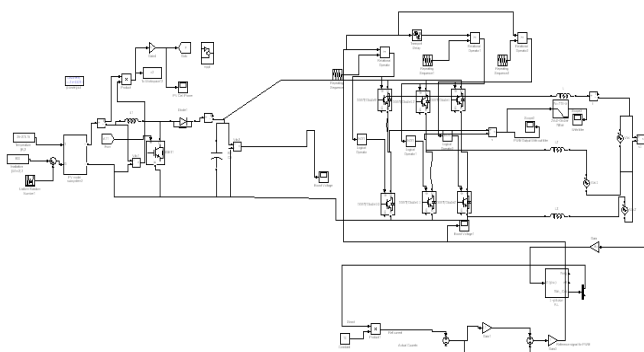

Fig.13. Matlab/Simulink model of Three phase PV proposed system applied to grid

As above Fig.13. Shows the Matlab/Simulink model of three phases PV proposed system applied to grid.

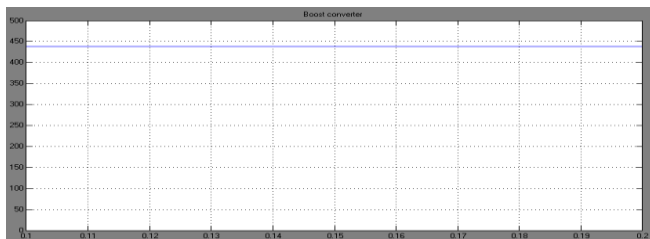

Fig.14. shows the output voltage of boost converter with PV proposed system

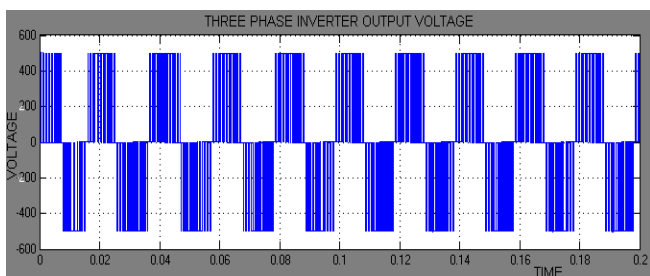

Fig.15 Output voltage of inverter without filter

Fig.15. Shows the Output voltage of inverter without filter, with PV proposed system.

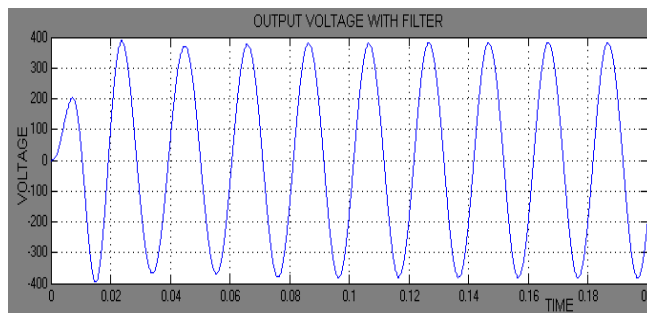

Fig.16. Output voltage of inverter with filter

Fig.16. Shows the Output voltage of inverter with filter, with PV proposed system. Here we are using normally second order filter for getting sinusoidal waveform instead of square wave form.

CONCLUSION

The characteristic equation of the solar cell is successfully validated in this paper using MATLAB/Simulink. The model in Simulink is ready for further research work as proposed and same proposed PV system is applied to grid by using single phase and three phase interfacing inverter and same system applied to grid.

REFERENCES

- [1] Joe-Air Jiang, Tsong-Liang Huang, Ying-Tung Hsiao and Chia-Hong Chen, "Maximum Power Tracking for Photovoltaic Power Systems", Tamkang Journal of Science and Engineering, Vol. 8, No 2, pp. 147_153 (2005)
- [2] Huan-Liang Tsai, Ci-Siang Tu, and Yi-Jie Su, "Development of Generalized Photovoltaic Model Using MATLAB/SIMULINK", Proceedings of the World Congress on Engineering and Computer Science 2008 WCECS 2008, October 22 - 24, 2008, San Francisco, USA
- [3] S.P. Sukhatme, "Solar Energy- Principles of thermal collection and storage", Tata McGraw Hill Publishing Company Limited, New Delhi (1984)
- [4][online]Available:http://en.wikipedia.org/wiki/Solar_azimuth_angle
- [5][online]Available:http://en.wikipedia.org/wiki/Solar_elevation_angle