

Harmonic Analysis of a Specified output voltage with improved power quality AC -DC dual converter fed four Quadrant DC Drive

¹B.PRAVEEN KUMAR,¹Asst.Professor ²S.Trilochana²Asst.Professor ³D.JOSEPH KUMAR ³Asst.Professor

¹EEE DEPARTMENT

²EEE DEPARTMENT

³EEE DEPARTMENT

¹DNR COLLEGE OF ENGINEERING & TECHNOLOGY, BHIMAVARAM,AP,INDIA

²GVVIT COLLEGE OF ENGINEERING & TECHNOLOGY, TUNDURU,AP,INDIA

³DNR COLLEGE OF ENGINEERING & TECHNOLOGY, BHIMAVARAM,AP,INDIA

¹praveenraidynamic227@gmail.com ²trilochana243@gmail.com ³josephkumar023@gmail.com

ABSTRACT:-

Single Phase AC-DC Converters have been developed to a Matured Level, however this paper Investigates Improved Power Quality in terms of Power Factor Correction ,reduced Total Harmonic Distortion at input AC mains .The Converter topologies ,capable of functioning as Bidirectional Buck Converters are Simulated for Buck Modes, which outputs variable bidirectional DC voltage and reversible Current employing discrete [power IGBTs] components based four quadrant switches[4 QSW].the operation of the Separately excited DC Machine in each of the four Quadrants when fed by the symmetrical Multipulse Modulated ,Improved power quality. The armature Control of the DC machine with Constant Load Torque is undertaken in both Clockwise and Anti Clockwise directions in the Motoring and Generating Mode. The Results of the Simulations Confirm the Feasibility and Predicted performance indicates at the AC interface the Harmonic Profile of the Proposed drive fed by the improved power Quality dual converter can be manipulated to enable use of a simple filter compared to those in the SMM Technique

INDEX TERMS:-Dual Converter, Harmonic Reduction, Improved Power Quality, Single Phase AC-DC converter, Phase Control, Symmetrical Multipulse Modulation.

I INTRODUCTION:-

Traditionally Solid State AC-DC Converters are designed using Diodes and Thyristors to provide Controlled and Uncontrolled and Bidirectional DC Power. They have the problems of injected current Harmonics, resultant voltage Distortion and poor

power factor at input AC Mains and slowly varying rippled DC output at load end, low efficiency .In view of stringent requirement of power quality at the AC mains and their increased applications , a new breed of converters have been developed using new Solid –state self –commutating device such as MOSFETs,IGBTs,GTOs

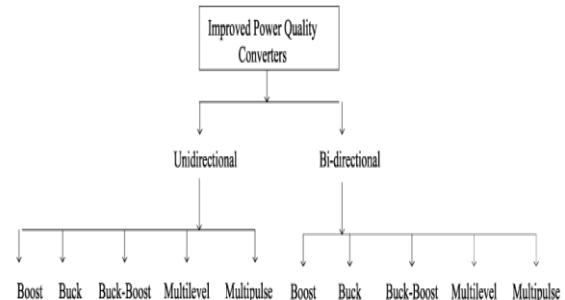

Converter-based classification of improved power quality converters.

These Converter are referred as improved power quality Converter [IPQC].IPQC technology has matured at a reasonable level for AC-DC Conversion with reduced Harmonic Currents , high power factor ,low Electromagnetic Interference[EMI] and Radio frequency Interference [RFI] at input AC mains and well regulated and good quality DC output to feed loads .However the increased use of the Contemporary improved power quality AC-DC Converters[IPQCs] [1].The four quadrant DC Drive operation is well established .In this paper the performance of the separately excited DC Machine fed by a single phase , symmetrical Multipulse Modulated, Improved power Quality, Dual AC-DC

buck Converter is investigated from of operation . The Armature Control Method of the DC Machine that provides constant Torque operation is undertaken in both clockwise and anticlockwise directions in the motoring and Generating modes. The Performance of the proposed drive in each quadrant is compared with that of the single phase, phase control based AC-DC converter. The Simulation based performance evaluation of the drive indicate that the proposed drive has potential for better values of Total Harmonics Distortion (THD) by using a Filter apart energy Saving.

The Symmetrical Multipulse Modulation[SMM] [2] technique is adopted, wherein; Several equidistant pulses per half cycles(M) are used to obtain an output voltage that can be continuously varied by varying the duty cycle(δ) of the pulses. The Technique continues to evoke interest as it is relatively less complex and therefore easy to implement. The Separately excited DC machine based drive is chosen to exploit the advantages that are inherent to decoupling between the armature and excitation electromagnetic systems including better dynamic response, better stability etc. The Circuit diagram of the Proposed four quadrant drive is shown in Figure.1. It comprises the dual buck converter that is essentially inverse parallel connection of two bi-directional buck converter that has the single-phase source connected to the AC side via Step up Transformer TR and the Armature Winding A_1A_2 of the DC Machine Connected to the DC Side

II TOPOLOGICAL CONSIDERATIONS:- DUAL BUCK CONVERTER

The Dual Buck Converter Provides a Similar function as a Conventional Thyristor Bridge Converter but with improved Power Quality interms of High Power Factor and reduced Harmonic currents at AC mains and fast regulated Bidirectional output voltage for reversible power flow. The power semi converters are GTOs at higher power ratings and Transistors at low power ratings with High Switching Frequency. The use of Transistors IGBTs necessitates a series diode with every Transistor to provide the reverse voltage Blocking Capability. This two device combination comprising series connection of a Transistor and a diode constitutes a Two Quadrant

Switch [2QSW] with Controllable turn-on and turn-off of Unidirectional Current and Bidirectional Voltage Blocking Capability. The Diodes have to be of the fast recovery type to ensure that the low turn-on and turn-off times Characteristic of the IGBTs are not comprised. The series diodes apart from providing the bipolar blocking ability to the transistors also ensure that the relevant IGBTs alone are effective in a particular half cycle.

In the Figure. I the circuit shows two sets of Subsystems devices [I and II] every set has four 2 QSWs having IGBT and diode in series constitutes a Dual Buck converter. The four 2QSWs of set I are D_1M_1 , D_2M_2 , D_3M_3 , D_4M_4 and other set II $D_1^1M_1^1$, $D_2^1M_2^1$, $D_3^1M_3^1$, $D_4^1M_4^1$ The dual buck converter referred inverse-connection of two bidirectional buck converter . The four Combinations of two 2QSWs in inverse parallel connection of 2QSWs Constitutes a four quadrant switch[4 QSW] that can provides controllable turn-on and turn-off bidirectional current and bidirectional voltage blocking . In the figure-I, E =Induced emf in the Armature and DFW=Freewheeling Diode.

III PWM TECHNIQUE IN THE SINGLE PHASE DUAL AC-DC BUCK CONVERTER

The Dual Buck converter Operates in both of the modes rectification or inversion corresponding to the DC Machine functioning in the Motoring or Generating modes respectively and in particular quadrant in the speed –Torque shown in the Figure.2 is obtained by the Switching Conditions of the IGBTs of the two sets [I and II] of devices. In given Figure.2 the different Parameters indicates as Follows:

T_L =Load (External Mechanical) Torque.

T_M = Electromagnetic (Internal) Torque.

$G\Omega$ = Rotor (Mechanical) Speed

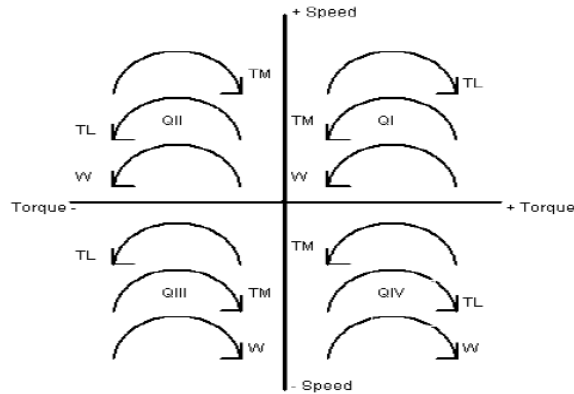

The Switching conditions of the Two sets of devices in the converter for the four Quadrant operation shown in the given below Table-I

Fig. 2. Speed-torque plane with the four quadrants demarcated.

TABLE I
CONDITIONING OF SWITCHING STATES OF THE TWO SETS OF IGBTs IN THE DUAL BUCK CONVERTER

Mode	Converter Operation	Quadrant (Q)	Set I IGBTs (M1,M2,M3,M4)	Set II IGBTs (M1',M2',M3',M4')	Armature Winding (A ₁ A ₂) Connection & Other Criterion
Motoring	Rectification	I	SMM switching pattern A	OFF	A ₁ to P, A ₂ to N,
	Rectification	III	OFF	SMM switching pattern A displaced by 180°	A ₁ to P, A ₂ to N, reverse DFW.
Generating	Inversion	II	SMM switching pattern A displaced by 180°	OFF	A ₂ to P, A ₁ to N, E > amplitude of H.V. winding voltage, reverse DFW.
	Inversion	IV	OFF	SMM switching pattern A	A ₂ to P, A ₁ to N, E > amplitude of H.V. winding voltage.

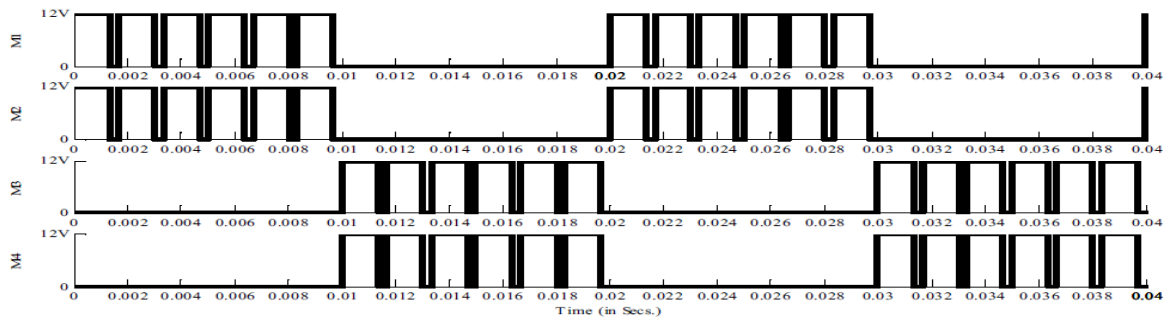

Fig. 3. Gate signals (switching pattern A) of the set I IGBTs, as per SMM technique with M = 6 and δ = 0.8, for I quadrant operation of dc drive.

For the Successful realization of power Transfer from the DC link to the AC source the Converter has to be achieved by maintaining the Machine in the generating mode, connecting the Armature Winding A₁ A₂, with making the polarity across the DC link keeping the magnitude of its induced emf E, greater the the amplitude of the Transformer HV side Voltage and Imparting a phase Shift of 180° to the gate switching control of the set-I or set-II IGBTs corresponding to the rectification operation in

Quadrant-I or III and to obtain Inversion in Quadrant-II or IV respectively

The field Winding F₁F₂ is connected to a Time invariant DC Voltage. The Armature Winding A₁ A₂ Is connected to the DC side of the dual converter. The Symmetrical Multipulse Modulation [SMM] involves chopping of the sinusoidal Voltage sources by several equidistant pulses per Half Cycle [M]. The output. The Fundamental component Magnitude and that the r.m.s value of the output voltage and its

Harmonics profile can be varied continually by changing the duty cycle (δ) pulses and

M. Thus, in the case of the SMM Technique there are options of changing number of Pulses per Half Cycle (M) keeping δ constant or the Duty cycle (δ) keeping M fixed to obtain a specific output voltage. Both the Strategies have been used in this paper; and the change in the power Quality parameter viz. power factor and THD on the ac side have been recorded and interpreted.

IV SIMULATION OF FOUR QUADRANT DC DRIVE

The rotation of speed ω and Torque in the clockwise and anti-clockwise are considered as positive and negative respectively. The motion of the drive is said to be reverse and forward when it rotates in the clockwise and anti-clockwise directions respectively. The load Torque always opposes the Electromagnetic Torque. In the motoring mode the electromagnetic torque is greater than the load torque i.e $T_M > T_L$. This implies that in this mode T_M is the driving torque and therefore, the angular speed, ω has a direction of rotation same as that of T_M . In the Generating mode $T_L > T_M$ i.e T_L is the driving torque and, hence ω has the direction of T_L . The magnitude of ω is proportional to the difference in the magnitude of T_M and T_L . The electrical power of the machine is given by the product of the electromagnetic torque T_M and the angular speed ω . If the electrical power, thus computed is positive or negative sign then the drive is Estimate to be absorbing or delivering power respectively, corresponding to the generating or motor modes respectively. The drive direction is determined by the direction of speed ω .

From the above, operation of four quadrants are determining as follows:

QI = Forward motoring QII = Forward generating
QIII = Reverse motoring QIV = Reverse generating

The Dc machines Armature control is obtained by keeping the field excitation flux constant by connecting the field winding $F_1 F_2$, to a firm time invariant DC source and applying varying voltages to the armature winding, $A_1 A_2$, by sensibly changing the duty cycle(δ) and the number of pulses per half

cycle(M) so as to make sure non-adverse impact viz. be short of adequate voltage at start, polarity, etc. Reversal of the electromagnetic torque is obtained by reversing the armature current I_a , direction. No filters for justifying ripple on the DC link and simple filter is used for harmonics on the ac side have been considered in the simulation model. The machine magnetic is assumed to be in the linear region free from saturation.

A TRANSFORMER PARAMETERS

A Transformer TR, is used in the model to step up that ac voltage source to an proper level as to attain a mean value of the dc voltage adequate with the armature voltage rating of the dc machine. Its parameters are:

Rating: 10KVA, 50Hz

L.V Side $V_1=230V, R_1=0.002p.u., L_1=0.087p.u$

H.V Side $V_s=265V, R_2=0.002p.u., L_2=0.08p.u$

Core: $R_m=500p.u., L_m=500p.u.$

The Transformer voltage ratio is determined on the basis of the average value of the DC voltage of the converter for $\delta=1.0$ given as below

$$\frac{2\sqrt{2}}{\pi} V_s = V_{dc}$$

Where

V_s = Transformer H.V side terminal voltage (rms value)

V_{dc} = Average value of DC voltage of the Converter

$V_{dc}=240V$ (rated armature voltage corresponding to $\delta=1.0$ from the above equation since the maximum value of the HV side of transformer is $v_s=265V$. Thus the Transformer voltage ratio has been taken as 230/265.

B.DC MACHINE PARAMETERS

The Parameters of the Separately Excited DC Machine considered in the simulation model are as follows:

Machine Rating: 5HP, 540V, 1750rpm, Field: $V_r=300V$

Armature Winding: $R_a=2.581\Omega, L_a=0.028H$

Field Winding: $R_f=281.3\Omega, L_f=156H$

Field-armature mutual inductance: $L_{af} = 0.9483H$

Total inertia: $J=0.02215kg\cdot m^2$

Viscous friction coefficient: $B_m = 0.002953NmS$

Coulomb friction torque: $T_r=0.5161Nm$

Initial speed: 1 rad.sec-1

C ASSUMPTIONS IN CONVERTER TOPOLOGY AND AC-DC SYSTEMS

Consider all the power semiconductor devices are assumed to be ideal. In the simulation of the drive an ideal sinusoidal ac voltage source is used. Operation in each quadrant is done maintaining a load torque of constant magnitude to ensure the electrical loading of the machine remains the same for both phase control

,the symmetrical Multipulse modulation technique and a simple filter is used to facilitate a fair comparison of the Characteristics. These Topology devices used with unsurpassed performance because of higher switching rate and negligible losses.

V.CIRCUIT DIAGRAM, RESULTS AND DISCUSSION

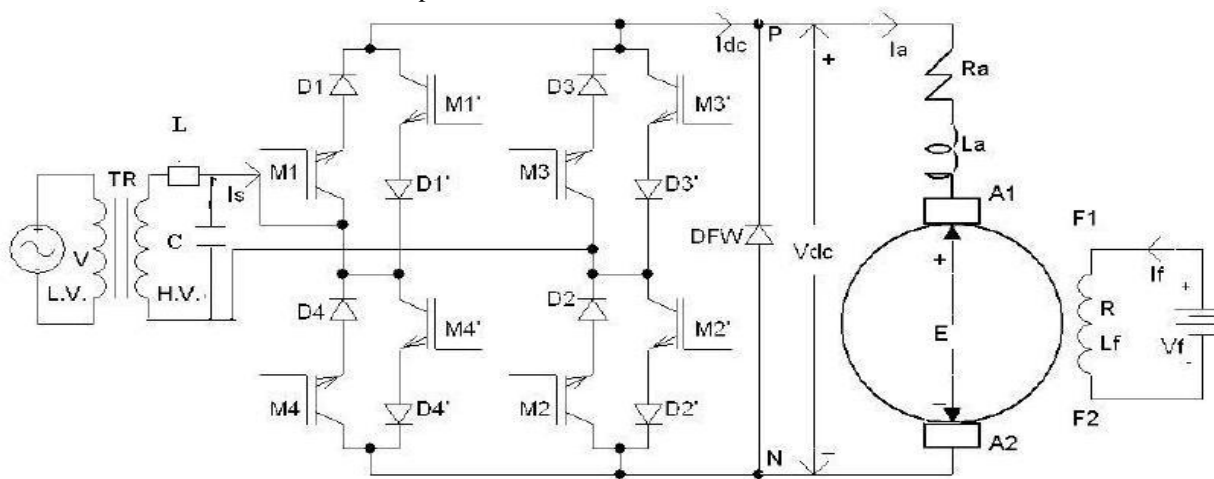

Fig.1 Improved power Quality,single phase,Dual Ac-Dc Buck Converter fed Four Quadrant,Armature Controlled,Separately Excited DC Drive Using Filter

A. Symmetrical Multipulse Modulated (SMM) Dual Buck Converter Fed Four Quadrant Operation of DC Drive.

The most simple of Multipulse modulation technique is SMM has the pulses are of equal width and placed equidistant from each other and, therefore do not require the usual reference and carrier wave control combination for generation. They can be predetermined by digital logic synchronizes with a zero crossing detector output latched to the ac side fundamental frequency. The output voltage in the SMM technique is controlled by the number of pulses per half cycle (M) and their duty cycle (δ).

The Characteristics of the dc drive obtained by use of the technique with $M=6$ is given in the Figure, pertaining to forward motoring mode (I Quadrant), forward generating mode (II Quadrant), reverse motoring mode (III Quadrant) and finally reverse

generating mode (IV Quadrant) respectively. The duty cycle (δ) of the pulses has been kept at 0.7 and 0.8 corresponding to 0.8 p.u and 0.7 p.u. of the rated armature voltage for I, II, III and IV quadrants respectively. Here involving the transient at the starting of the drive has been shown for both forward and reverse motoring operations in fig . It is apparent that the starting in fig is fairly softer (i.e less starting current) and the magnitude of the maximum Torque is lower because of the application of reduced voltage, conversely the steady state torque in both cases is same i.e is 20Nm.fig 2. show the plot for forward and reverse generating modes respectively that correspond to 0.8 p.u. and 0.7 p.u. of the rated armature voltage. As explained in the section the generating mode in both directions is characterized by high. Here the technique SMM involves several switching of the conducting devices within the relevant half cycle and, therefore, the apart of the freewheeling diode across the armature is very significant. It ensures that the armatures current is continuous and of low ripple content be smooth and

non-smooth jerky. The freewheeling diode also ensures that the voltage is free from spikes of large magnitudes and is unipolar. This is very important for the protection of the insulation of the armature winding and if not provided for leads to failure of the winding and, hence the machine itself. The SMM technique involves multipulses within a half cycle (M) hence the duration of each pulse for small. The duty cycle of the pulses (δ) is typically high above 0.6 not including perhaps during starting; therefore, the off-time is low. The technique provides better power quality in terms of total harmonic distortion (THD) when M and δ are high. The self-commutating devices such as IGBTs employed in the converter are, thus, better utilized in terms of their switching speed and this also implies that the off-time is lowered. The moment of inertia of the rotor is a factor as well. These aspects ensure that the armature current, hence torque of the machine is smooth and machine characteristics are not comprised.

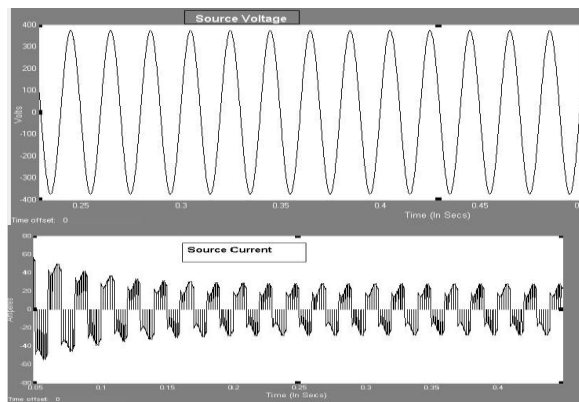

Fig 4 (a).Quadrant I:- H.V ac side voltage & current for M=6& $\delta=0.8$

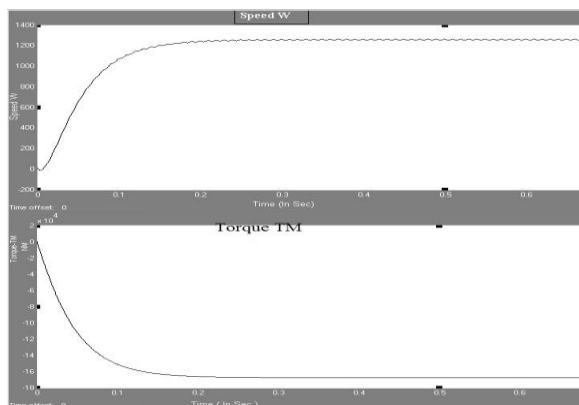

Fig 4 (b) Quadrant I:- Speed & Electromagnetic Torque for M=6& $\delta=0.8$

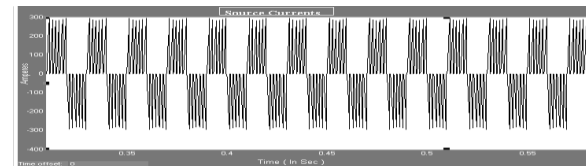
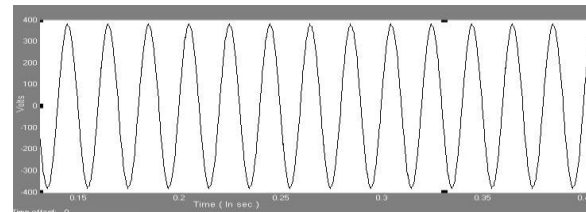

Fig 5 (a) :- H.V ac side voltage & current for M=6 &

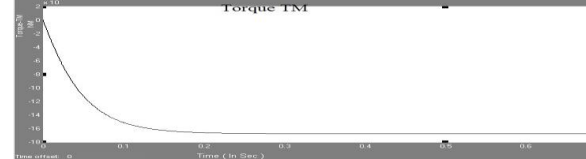
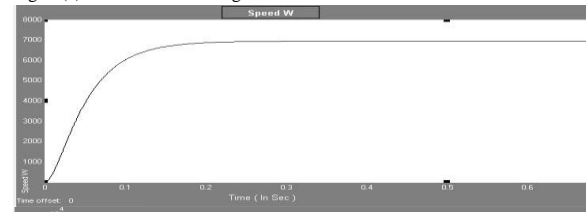

Fig 5 (b) Quadrant II :- speed & Electromagnetic Torque for M=6 & $\delta=0.8$

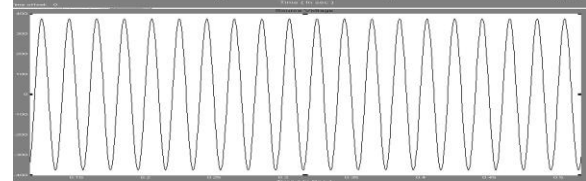
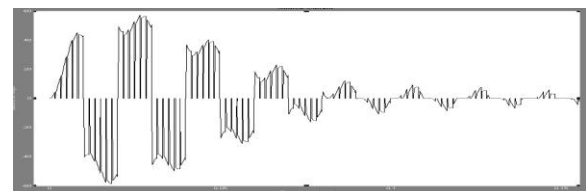

Fig 6(a).Quadrant III :- H.V ac side voltage & current for M=6& $\delta=0.8$

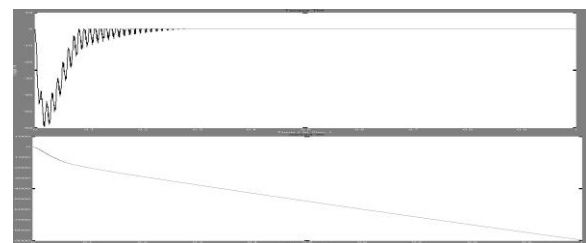

Fig 6 (b) Quadrant III:- Speed & Electromagnetic Torque for M=6& δ

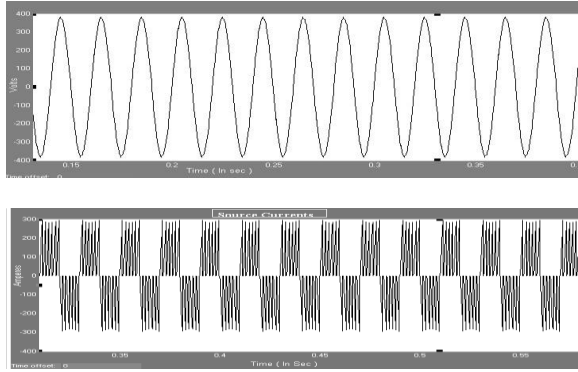

Fig 7(a).Quadrant IV:- H.V ac side voltage & current for $M=6$ & $\delta=0.8$

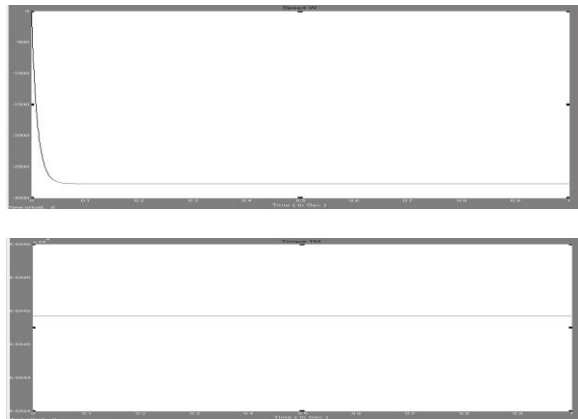

Fig 7 (b) Quadrant IV;_speed & Electromagnetic Torque for $M=6$ & $\delta=0.8$

A. Symmetrical Multipulse Modulated (SMM) Dual Buck Converter Fed Four Quadrant Operation of DC Drive with Filter for a specific output Voltage.

The Control Strategy is implemented SMM the most simple of Multipulse Modulation Technique as the Pulses are of equal width placed equidistant from each other. Hence the Simulation based performance analysis of both rectification and Inversion i.e., four Quadrant operation in Buck modes, of Single Phase versions of the BI-directional Buck Converter are Presented. The Input current can be comprising into any determine Pulses per Half Cycle, and the Source Voltage waveform obtained when the single-phase converter in simulated in the buck mode operation of four quadrant. The value of the line Inductor employed as the buffer element in the Buck mode an between the generated voltage and the Main Ac voltage Converter, it is crucial for shaping the input current. For the low value of this inductor large switching ripples are injected into the supply current

and a high value does not permit shaping of the AC source current. In the Buck mode the value of the DC link capacitor is crucial. Here a low value of capacitor placed and cause steady-state and rise in DC link voltage under Transient condition. The value of the Inductor and Capacitor as the Input Filter in the Buck mode is also important the AC voltage and Current Waveforms for the single Phase Bi-directional Buck Converter.

The characteristics of the DC Drive can be obtained by use of the Technique. Given below in the Fig.(A)(A)A(A)A(A) to I Quadrant forward Motoring Mode and III Quadrant Reverse Motoring Mode ;II Quadrant Generating Modes and IV Quadrant Reverse Generating Mode . The initial Transient where in the induced emf builds up in the Armature winding is not shown. The Technique SMM involves the Multiple Switching of the conducting devices with in relevant half cycle and, the role of the freewheeling diode across the Armature is very important. It is to make sure that the Armature current is continuous and of low ripple content. These are important for the Torque developed in the Armature to be smooth and Non-Jerky. The Freewheeling also ensure that the voltage is free from spikes of large magnitudes and is Unipolar. This is very important for the protection of the insulation of the Armature winding and if not provided for leads to failure of the winding and, the Machine itself. Here the SMM Technique involves Multiple Pulses within a half cycle (M) with a Filter. During Starting and Off-Time is Low. The Technique provides better power Quality in terms of Total Harmonics Distortion [THD] when M and δ are high.. The low Total Harmonic Distortion [THD] at the number of Pulses can be seen. If the low Total Harmonic Distortion [THD] at the number of Pulses can be given for the specified output the Total Harmonic Distortion [THD] can be reduced. The self-Commutating devices such as IGBTs employed in the Converter are better utilize in terms of their Switching speed and lowered of time. The moment of Inertia of the rotor factor in well. Here both the Technique Characteristics with Filter and Without Filter is well Compared. **NOTE:-** While in the 2 & 4 Quadrant the filter Configuration should be change .

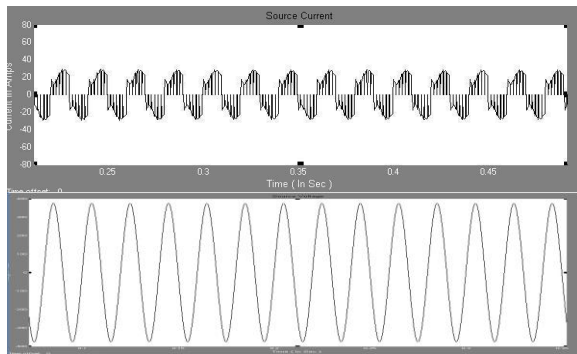

Fig 8 (a).Quadrant I:- H.V ac side voltage & current for M=6& $\delta=0.8$

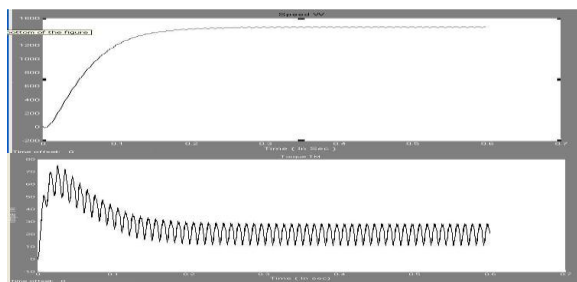

Fig 8(b) Quadrant I:_speed & Electromagnetic Torque for M=6 & $\delta=0.8$

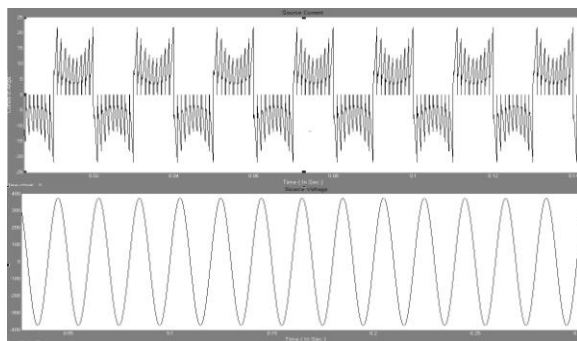

Fig 9 (a).Quadrant II:- H.V ac side voltage & current for M=6& $\delta=0$.

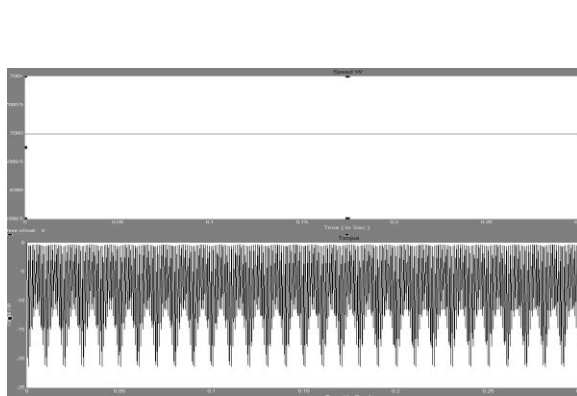

Fig 9(b) Quadrant II:_speed & Electromagnetic Torque for M=6 & $\delta=0.8$

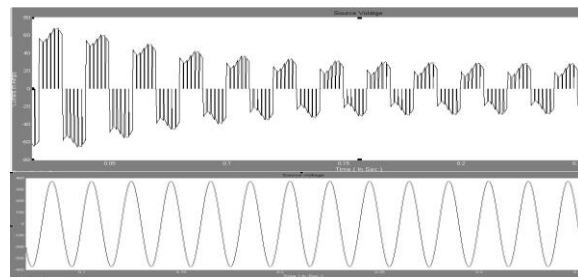

Fig 10 (a).Quadrant III:- H.V ac side voltage & current for M=6& $\delta=0.8$

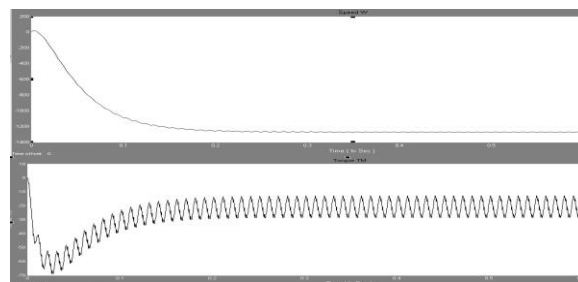

Fig 10 (b) Quadrant III:_speed & Electromagnetic Torque for M=6 & $\delta=0.8$

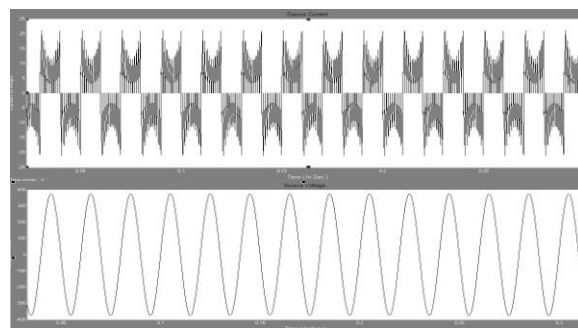
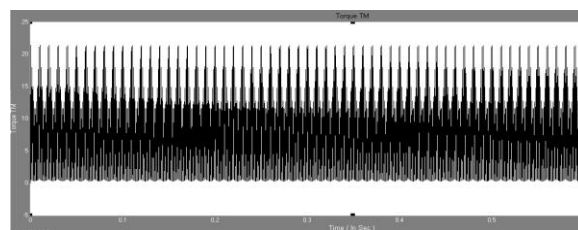

Fig 11 (a).Quadrant IV:- H.V ac side voltage & current for M=6& $\delta=0.8$



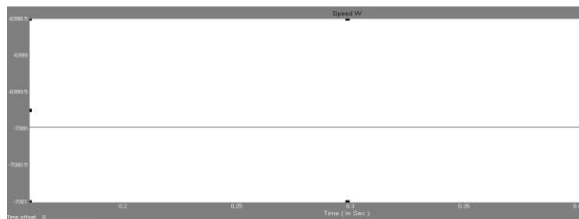
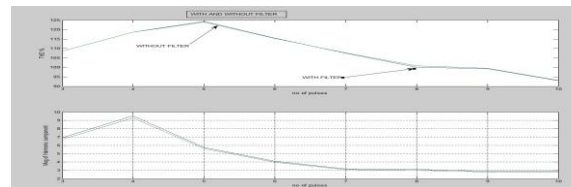
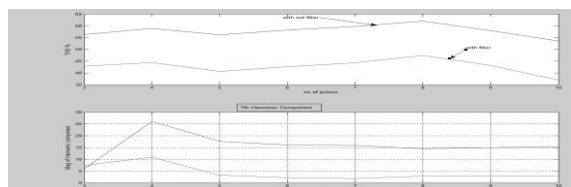

Fig 11 (b) Quadrant IV; speed & Electromagnetic Torque for $M=6$ & $\delta=0.8$

Data for Harmonics Distortion with Symmetrical Multipulse Modulation with Filter for Specific Output



Quadrant II:- Specific Output Voltage =240V with and without filter & 7th harmonic component



Quadrant I:- Specific Output Voltage =240V with and without filter & 7th harmonic component

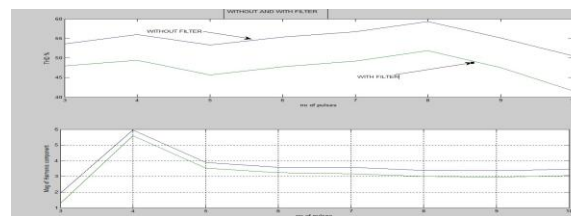

Quadrant III:- Specific Output Voltage =240V with and without filter & 7th harmonic component

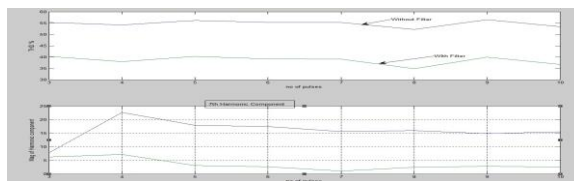

Quadrant I:- Specific Output Voltage =245V with and without filter & 7th harmonic component

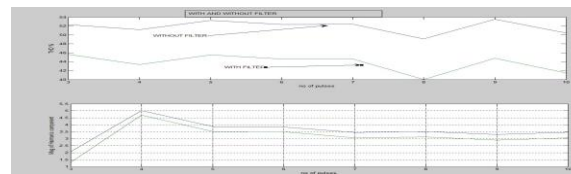

Quadrant III:- Specific Output Voltage =245V with and without filter & 7th harmonic component

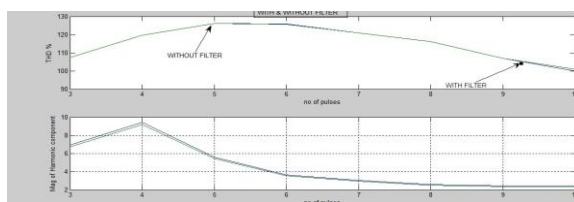

Quadrant II:- Specific Output Voltage =240V with and without filter & 7th harmonic component

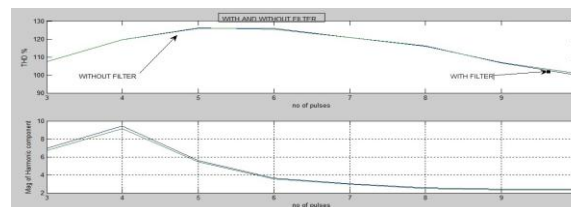

Quadrant IV:- Specific Output Voltage =240V with and without filter & 7th harmonic component

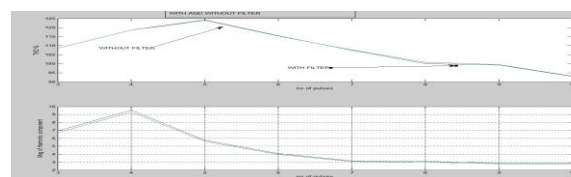

Quadrant IV:- Specific Output Voltage =245V with and without filter & 7th harmonic component

The four-quadrant operation has been shown for a single value of $M = 6$, however, simulations have been conducted with higher values of M and the

parameters obtained including the total harmonic distortion (THD) of the ac side current. It has also been observed that the harmonic profile for a specific voltage can be altered by changing M keeping δ constant and vice-versa. This feature of SMM is used to manipulate the Harmonic profile to ensure that the lower order harmonics are suppressed or even eliminated by judiciously selecting M and δ , thereby ensuring only those of the higher order are present. The higher order harmonics are filtered relatively easily and results in the use of filters that are economical, compact, and of lower weight.

The data for the SMM and SMM with Filters for a specific output are shown in the waveforms are tabulated in Table III. It is apparent that the values of THD obtained by this method are lower and, therefore, is a better technique than SMM. However, in this method neither can the harmonic profile be altered nor is harmonic mitigation and selective harmonic elimination inherent. It has been verified [7] by the author that the SMM method gives much lower values of THD as well for higher value of M for static loads. The author is curious if the same hold good for drives as well. The efforts towards this research are already underway.

VI. CONCLUSIONS

The separately excited dc machine drive for a specific output voltage has been analysed for harmonic content in the four quadrants of operation with Symmetrical Multipulse Modulation and symmetrical Multipulse modulated Technique with filter dual buck converter.

VII. REFERENCES

- [1] Bhim Singh, B.N. Singh, A. Chandra, Kamal Al-Haddad, Ashish Pandey, and D.P. Kothari, "A Review of Single-Phase Improved Power Quality AC-DC Converters," *IEEE Trans. Ind. Electron.*, vol. 50, No. 5, pp. 962-981, October 2003.
- [2] A. Mozdzer, Jr. and B. K. Bose, "Three-phase ac power control using power transistor," *IEEE Trans. Ind. Appl.*, vol. IA-12, pp.499-505, Sept./Oct., 1976.
- [3] K. E. Addoweesh and A. L. Mohamadein, "Microprocessor based harmonic elimination in chopper type AC voltage regulators," *IEEE Trans. Power Electron.*, vol. 5, pp. 191-200, Apr.1990.

- [4] G. M. Hashem and M. K. Darwish, "Generalized symmetrical angle PWM technique for ac voltage controller," in *Proc. IEEE UPEC'04*, 2004, pp.898-901.

- [5] A. N. Arvindan, V. K. Sharma and M. Subbiah, "Harmonic Analysis of Microprocessor based Three-Phase Improved Power Quality AC/AC Voltage Controller using Power MOSFETs," in *Proc. IEEE ISIE'06*, 2006, pp.763-768.

- [6] A. N. Arvindan and V. K. Sharma, "Microprocessor based Symmetrical Multipulse Modulation in a Three-Phase Improved Power Quality AC-AC Converter using Four Quadrant Switch Realizations" in the *Institution of Electronics and Telecommunication Engineers (IETE), New Delhi, India, Journal of Research (ISSN 0377-2063)*, Vol 53, No. 6, pp. 563-571, Nov.- Dec.2007.

- [7] A. N. Arvindan, "Power Quality Assessment in a Bi-directional AC/AC Converter with Four-Quadrant Switch Realizations" in *Proc. IEEE TENCN'08*, 2008, session P12.

- [8] *IEEE Recommended Practices and Requirements for Harmonics Control in Electric Power Systems*, IEEE Std. 519, 1992.