

Double Input Z-Source DC-DC Converter Fed with Separately Excited DC Motor

Shobhan babu.B¹, B.Sreenu²

**(Department of EEE, Anurag engineering college, JNTU- Hyd, TS, INDIA)
Email:shoban204@gmail.com*

*** (Department of EEE, Anurag engineering college, JNTU-Hyd, TS, INDIA)
Email:sreenueee777nits@gmail.com*

ABSTRACT: The Z-source converter employs a unique impedance network (or circuit) to couple the converter main circuit to the power source, thus providing unique features that cannot be obtained in the traditional voltage-source and current-source converters where a capacitor and inductor are used, respectively. The Z-source converter overcomes the conceptual and theoretical barriers and limitations of the traditional voltage-source converter and current-source converter and provides a novel power conversion concept.

The project deals with double input z-source dc-dc converter fed with separately excited dc motor. The proposed converter, the input dc voltage can be boosted and also input dc sources can deliver power to the load individually or simultaneously, so combination of a battery with one of the new energy sources such as solar array, wind turbine or fuel cell can be used as input sources. Different states of double input Z-source dc-dc converter are analyzed, steady state operation of converter is explained and modeling of separately excited dc motor is explained in detail. The simulation is done using MATLAB/SIMLINK. Finally, the simulation results are presented to confirm the theoretical analysis.

Keywords: Z -source converter; double input; dc-dc converter; dc motor.

I.INTRODUCTION

The renewable energy such as photovoltaic (PV) and wind has created various electric energy sources with different electrical characteristics for the modern power system. In order to combine more than one energy source, such as the solar array, wind turbine, fuel cell (FC) and commercial ac line to get the regulated output voltage, the different topologies of multi input converters (MICs) have been proposed in recent years [1]-[4].

Traditionally, two dc voltage sources are connected to two independent dc-dc power converters to obtain two stable and equivalent output voltages, which are then connected to the dc bus, to provide the electric energy demanded by the load.

Another approach for the double-input dc-dc converter is to put two dc sources in series to form a single voltage source where traditional dc-dc power converters can be used to transfer power to the load. In order to transfer power individually, each dc voltage source needs a controllable switch to provide a bypass short circuit for the input current of the other dc voltage source to deliver electric energy continuously [3], [4].

Another approach is to put PWM converters in parallel with or without electrical isolation using the coupled transformer [5]. Control schemes for these MICs with paralleled dc sources are based on time sharing concept because of the clamped voltage. Because of the voltage amplitude differences between two dc sources, only one of them can be connected to the input terminal of the dc-dc converter and transfer power to the load at a time [3].

The objective of this paper is to propose a dc motor fed with double input dc-dc converter which has the following advantages:

The dc sources can deliver power to the dc motor individually or simultaneously; the multi winding transformer is not needed; the magnitude of the input dc voltage can be higher or lower than the one with a regulated

Output; minimum switching devices are used in this circuit. The proposed double input dc-dc converter is proper for renewable-energy applications and combination of two different sources (such as battery and photovoltaic or fuel cell)

II. CIRCUIT CONFIGURATION AND PRINCIPLE OF OPERATION

A. Z-Source Converters

Z-source converters are modern group of power electronic converters which can overcome problems with traditional converters. The Z-source inverter is a novel topology [6] that overcomes the conceptual and theoretical barriers and limitations of the traditional voltage-source converter and current-source converter. The concept of Z-source was used in direct ac-ac power conversion [7]. Similarly, the

concept of Z-source also was extended to dc-dc power conversion [8].

B. Circuit Configuration of Proposed Converter

The schematic circuit diagram of the proposed dc drive fed with double-input Z-source dc-dc converter with two different voltage sources is shown in Fig. 1. It consists of two different input sources, V_{dc1} and V_{dc2} , and four diodes, D1-D4, applied to provide current path in different states. In this paper, permanent connection of input dc sources is considered, so D1 and D2 can be replaced with active switches if it's required to connect and disconnect each of sources to input side of converter frequently. Energy receiver, converter and transmitter sections are situated in the middle side of the converter. This section is a two-port network that consists of a split-inductor L1 and L2 and capacitors C1 and C2 connected in x-shape which is named "Z-network". An active switch, S, is situated in output port of Z-network to control input and output power of converter. The final section of converter is a LC filter beside the load in order to reject output signal ripple.

C. principle Operation of Double Input DC-DC Converter

There are four different operation states with respect to active or inactive states of dc sources. As previously mentioned, both of the input sources can deliver power to the load either individually or simultaneously through the MIC. When only one of the input sources feeds the MIC, it transfers power to the load individually and the MIC will operate as does a PWM converter. Table I summarizes the operation states of the proposed double input dc-dc converter

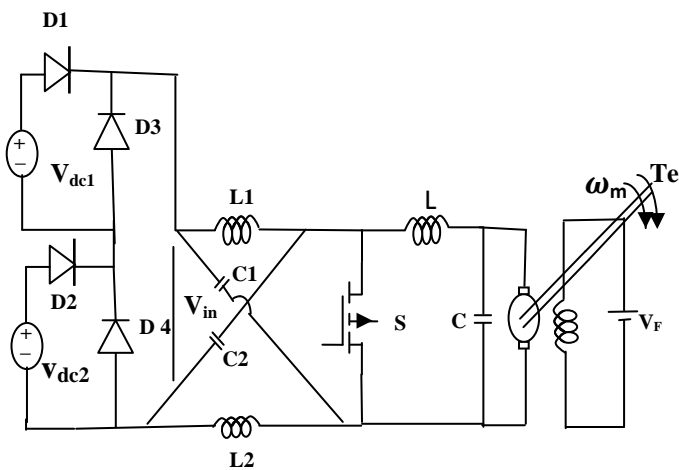

Fig1.DC Motor fed with double input Z-source DC-DC converter

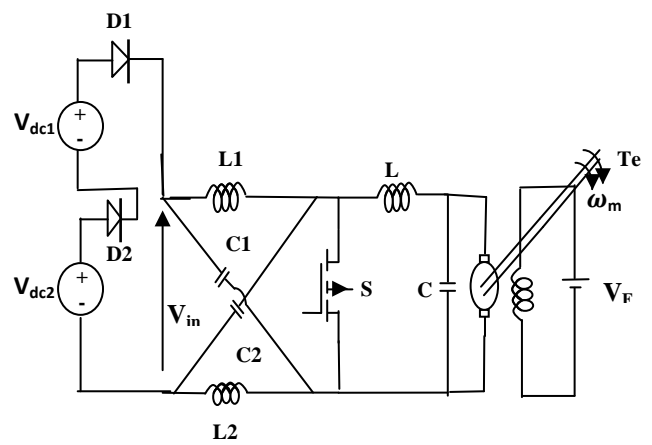

Fig2. Double input DC-DC converter state1 equivalent circuit

1) State 1, both source 1 and source 2 are active

Fig. 2 shows equivalent circuit of this state. When both source1 and source 2 are active, the converter input dc voltage is sum of voltage of two series dc sources, as Fig. 3 and (1) illustrate.

$$V_{in} = V_{dc1} + V_{dc2} \quad (1)$$

In this state, because both two sources are active, D1 and D2 are forward biased and D3 and D4 are reverse biased. Thus, the sources current enters in Z-network through D1 and D2 and after passing load impedance, comes back into sources through negative polarity.

2) State 2, source 1 is active and source 2 is inactive

The equivalent circuit of this state is shown in Fig. 3. In this state, source 1 is active, so only this source provides converter (consequently load) energy. Because of source 1 is active then D1 is forward biased and D3 is reverse biased, so current follows from D1 to Z-network to load.

TABLE I. STATES OF DOUBLE INPUT DC-DC CONVERTER

state	Sources States		Switches States				V_{in}
	V_{dc1}	V_{dc2}	D1	D2	D3	D4	
1	Active	Active	On	On	Off	Off	$V_{dc1} + V_{dc2}$
2	Active	Inactive	On	Off	Off	On	V_{dc1}
3	Inactive	Active	Off	On	On	Off	V_{dc2}
4	Inactive	Inactive	Off	Off	On	On	0

In reverse path from load to the source, current can't pass through source 2 and D2, so D4 is forcedly turned on and conduct current to source 1. In this state, converter input dc voltage is only provided by source 1, as (2) shows.

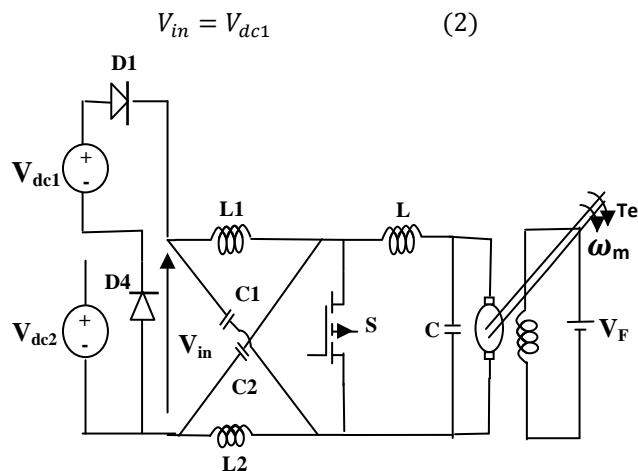

Fig3. Double input DC-DC converter state2 equivalent circuit

3) State 3, source 1 is inactive and source 2 is active

If source 1 is eliminated for each reason and source 2 is active, the converter can operate normally without effect of source 1 elimination. Fig. 5 shows the equivalent circuit for this state. In state 3, it's only source 2 that supplies converter and load. Source2 activation causes forward bias of D2 and reverse bias of D4. Because of source 1 disconnection, current passes through D3 and indeed, current turns it on forcedly to complete current path. In this state, converter input dc voltage is only provided by source 2, as (3) shows.

$$V_{in} = V_{dc2} \quad (3)$$

4) State 4, both source 1 and source 2 are inactive

Basically, this state is only following of one of the previously mentioned three states. Because in this state both dc sources are inactive and disconnected from converter, D1

And D2 are forcedly turned off and consequently, the only existing path for remain current, from previous state, is provided by D3 and D4. Thereupon, in state4 D3 and D4 are turned on. Fig. 6 shows equivalent circuit of this state. Input voltage is zero in this state as shown in (4).

$$V_{in} = 0 \quad (4)$$

Obviously, because both dc sources disconnect from converter, duration of this state is very short and when current descends to zero, whole of converter will be inactive.

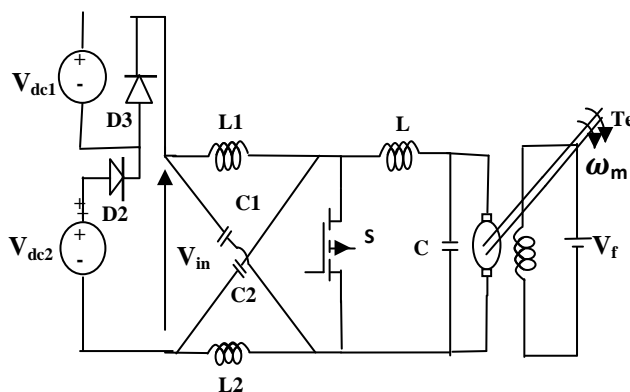

Fig4. Double input DC-DC converter state3 equivalent circuit

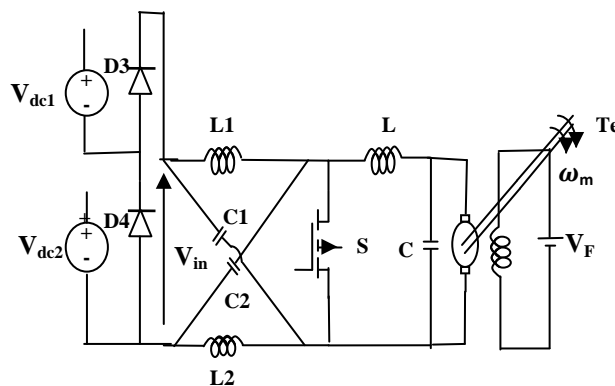

Fig5. Double input DC-DC converter state4 equivalent circuit

III. STEADY STATE ANALYSIS OF DC MOTOR FED WITH DOUBLE INPUT Z-SOURCE DC-DC CONVERTER

All four states of double input Z-source dc-dc converter can be analyzed in similar way, but in this section only first state is analyzed which can be applied to the other states. Fig. 3 is considered as converter circuit for steady state analysis.

Similar to the other Z-source inverter/converter topologies, Z-network of the Z-source dc-dc converter is also symmetrical, that is, the inductors L1 and L2 and capacitors C1 and C2 have the same inductance (L) and capacitance (C), respectively. From the symmetry and the equivalent circuits, the inductor and capacitor voltages have following relations [8]:

$$V_{C1}=V_{C2}=V_C, \quad V_{L1}=V_{L2}=V_L \quad (5)$$

There are two modes in steady state operation of converter circuit. In mode 1 diodes D1 and D2 are turned on and the switch S is turned off. The dc sources charge Z-network capacitors, while Z-network inductors discharge and transfer energy to the load. Converter operating interval in this mode is (1-D) T, where D is duty ratio of switch S, and T is switching cycle. Fig. 7 shows equivalent circuit of mode 1. Thus in this interval the following equations are received [8]:

$$V_{in} = V_{dc1} + V_{dc2} \quad (6)$$

$$V_C = V_{in} - V_L \quad (7)$$

$$V_o = V_{in} - 2V_L \quad (8)$$

In mode 2, switch S is turned on and D1 and D2 are turned off. Z-network capacitors discharge, while inductors charge and store energy to release and transfer to the load in the next interval. Converter operating interval in this state is DT. Fig. 8 shows mode 2 equivalent circuit. Following equation expresses this interval equivalent circuit [8]:

$$V_C = V_L, V_o = 0 \quad (9)$$

The average voltage of the inductors over one switching period (T) in steady state should be zero, so (6)-(9) result:

$$V_L = \int V_C \cdot DT + (V_{in} - V_C)(1 - D)T]dt \quad (10)$$

Considering (10) equal to zero, results following equation:

$$\frac{V_C}{V_{in}} = \frac{1 - D}{1 - 2D} \quad (11)$$

Similarly, the peak output voltage of converter in a Switching cycle can be expressed as follows:

$$V_L = 2V_C - V_{in} = \frac{V_{in}}{1-2D} \quad (12)$$

The average output voltage can be expressed as:

$$V_o = V_C = \frac{1-D}{1-2D} V_{in} \quad (13)$$

$$V_o = \frac{1 - D}{1 - 2D} (V_{dc1} + V_{dc2}) \quad (14)$$

This output voltage is given as the input to the DC motor.

Modeling of separately excited dc motor

$$V_a(t) = R_a i_a(t) + L_a \frac{di_a(t)}{dt} + e_b(t) \quad (15)$$

$$e_b(t) = K_b \cdot w(t) \quad (16)$$

$$T_m(t) = K_T i_a(t) \quad (17)$$

$$T_m(t) = J_m \cdot \frac{dw(t)}{dt} + B_m \cdot w(t) \quad (18)$$

Where V_a = armature voltage, R_a =armature resistance, L_a =armature inductance, i_a = armature current, e_b =back emf, $w(t)$ =angular speed, T_m =motor torque, J_m =rotor inertia. B_m =viscous friction coefficient, K_T =torque constant and K_b =back emf constant.

Eventually, the transfer function between angular speed and armature voltage at no load is

$$\frac{w(s)}{V(s)} = \frac{K_b}{s^2 J_m L_a + s(B_m L_a + R_a J_m) + (B_m R_a + K_b^2)} \quad (19)$$

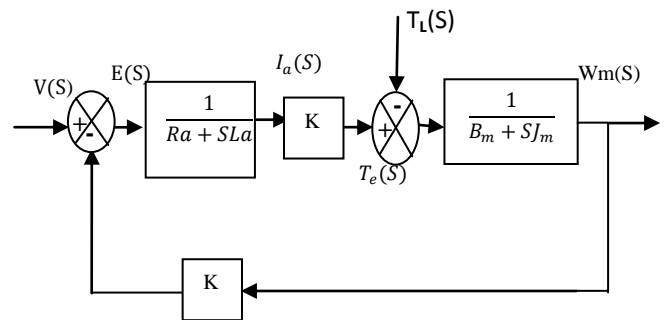

Fig.6 Block diagram of the DC motor

IV.SIMULATION RESULTS

Simulation of double input Z-source dc-dc converter fed dc motor was performed using MATLAB SIMULINK to confirm above analysis. Simulation consists of four sections that each section describes each state of converter. Converter parameters in the simulation were as in Table II.

TABLE II.SIMULATION PARAMETERS

parameter	value
Vdc1	100
Vdc2	40
C1=C2	1000µF
C	500µF
L1=L2=L	0.5mH
switching frequency	10KHZ
duty ratio	30%
Ra	0.5 Ω
La	0.01 mH
Jm	0.05kg.m ²
Bm	0.02N.m.s
TL	10N.m

Double input Z-source dc-dc converter fed dc motor is controlled by PWM duty cycle control. So by adjusting duty cycle, converter output voltage and speed of the dc motor are regulated. As previously mentioned, dc sources can supply converter individually or simultaneously. In this simulation independence of dc sources from each other is shown in four different states.

A. State 1, both source 1 and source 2 are active

For state 1, that both dc sources were active during simulation time, converter produced 244V by 30% duty cycle in boosting mode. Fig. 7 shows converter output voltage. Fig. 8 shows the electromagnetic torque and Fig. 9 shows the angular speed of the motor. Input current passed through D1 and D2 because these switches were forward biased and turned on. D3 and D4 were reverse biased, thus their currents were zero.

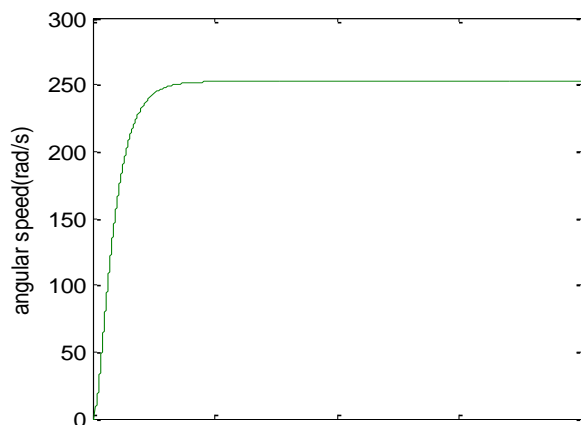

Fig9. Angular speed of the dc motor

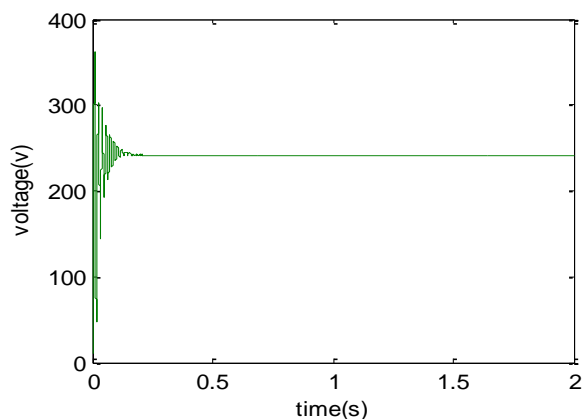

Fig7. Double input DC-DC converter output voltage in state 1

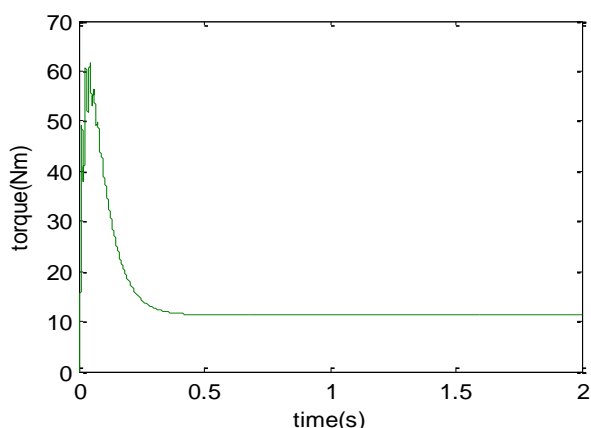

Fig8. electromagnetic torque of the dc motor in state 1

B. State 2, source 1 became inactive

For state 2, that source1 became inactive and disconnected from converter. Fig. 10 shows output voltage of the converter for state 2. As this figure shows output voltage decreased to 69V which is only source 2 stepped up dc voltage. Thus only source 2 supplied to converter independent of source 1. Simulation time, converter produced 69V by 30% duty cycle in boosting mode. Fig. 10 shows converter output voltage. Fig. 11 shows the electromagnetic torque and Fig. 12 shows the angular speed of the motor. Input current passed through D2 and D3 because these switches were forward biased and turned on. D1 and D4 were reverse biased, thus their currents were zero.

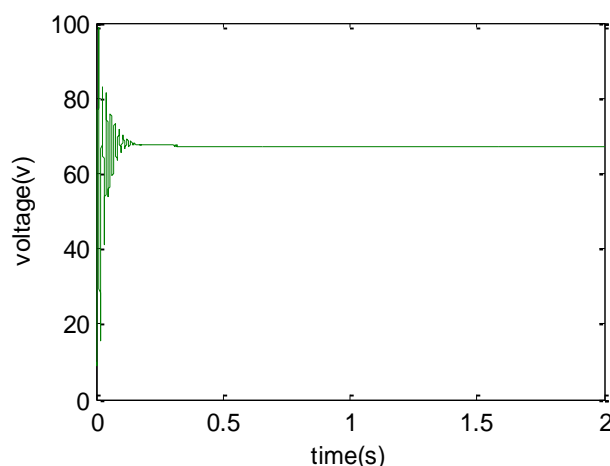

Fig10. converter output voltage in state 2

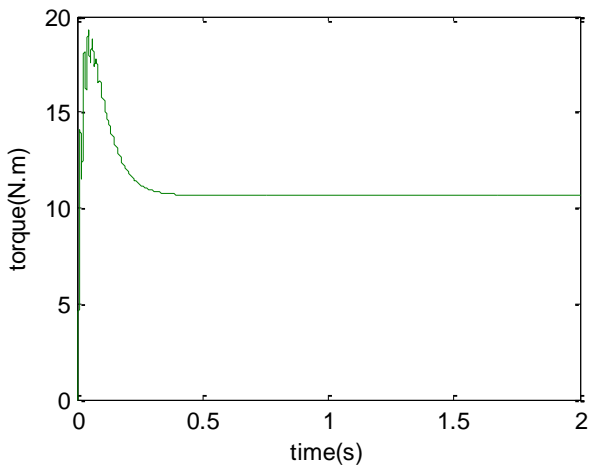

Fig11. electromagnetic torque in state 2

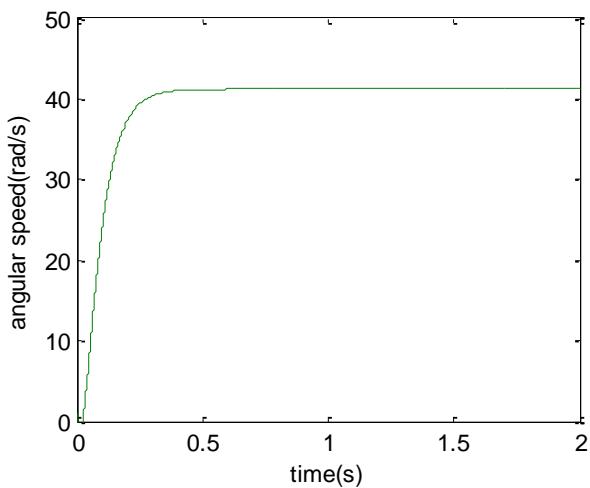

Fig12. angular speed of the dc motor in state 2

C. State 3, source 2 became inactive

Similar to the state2 , in state 3 Source 2 became inactive and disconnected from converter.fig.13 shows output voltage of the converter for state 3. As this figure shows output voltage decreased to 175V which is only source 1 stepped up dc voltage. Thus only source 1 supplied converter independent of source 2. Simulation time, converter produced 175V by 30% duty cycle in boosting mode. Fig. 13 shows converter output voltage. Fig. 14 shows the electromagnetic torque and Fig. 15 shows the angular speed of the motor. Input current passed through D1 and D4 because these switches were forward biased and turned on. D2 and D3 were reverse biased, thus their currents were zero.

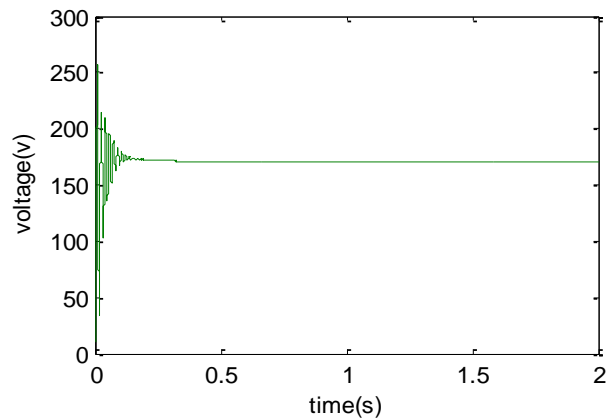

Fig13. converter output voltage in state 3

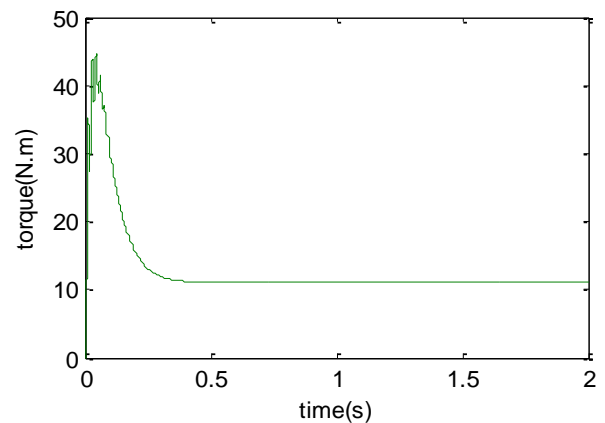

Fig14. electromagnetic torque of the dc motor in state 3

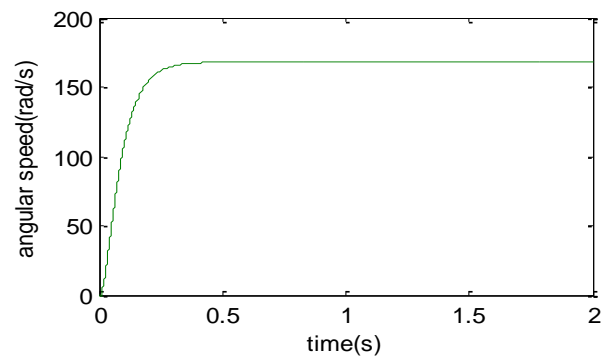

Fig15. angular speed of the dc motor state 3

D. state 4: Both source 1 and source 2 became inactive

This state is not considered as an active operation state, because both dc sources become inactive and indeed, there is not any source to supply converter and load. In this state D1 and D2 were turned off, therefore converter input current path switched to D3 and D4.

V. CONCLUSION

The paper has proposed a double input Z-source converter fed dc motor. This drive has the advantages of both dc motor and Z-source converter. The system configuration and operation principle have been analyzed in detail. Based on the equivalent circuits, the mathematical model has been established. Simulation results have validated the preferred features as well as the possibility of the proposed drive system.

REFERENCES

- [1] E. Muljadi and H.E. Mckenna, "power quality issues in a hybrid power system," *IEEE Trans. Ind. Appl.* vol. 38, pp. 803-809, May/ Jun 2002
- [2] F. Giraud and Z. M. Salameh, "Steady-state performance of a grid connected rooftop hybrid wind-photovoltaic power system with battery storage," *IEEE Trans. Energy Convers.*, vol. 16, no. 1, pp. 1-7, Mar 2001.
- [3] Yaow -Ming Chen, Yuan-Chuan Liu, and Sheng-sien Lin, "Double- Input PWM DC-DC Converter for High-/Low-Voltage Sources," *IEEE Trans. Ind. Electron.*, vol. 53, no. 5, October 2006.
- [4] Yuan-Chuan Liu and Yaow -Ming Chen, "A systematic approach to synthesizing multi-input dc-dc converters" *IEEE Trans. Power Electron.*, vol. 24, no. 1, January 2009.
- [5] H. Matsu, W. Lin, F. Kurokawa, T. Shigemizu, and N. Watanabe "Characteristics of the multiple-input dc-dc converter," *IEEE Trans. Ind. Electron.*, vol. 51, no. 3, pp. 625-631, Jun 2004.
- [6] F. Z. Peng, "Z-Source inverter," *IEEE Trans. Ind. Appl.*, vol. 39, no. 2, pp. 504-510, March/April 2003.
- [7] Xu Peng Fang, Zhao Ming Qian, and Fang Zheng Peng, "Single-phase Z-Source PWM AC-AC Converters," *IEEE Power Electron. Lett.*, vol. 3, no. 4, December 2005.
- [8] Xupeng Fang and Xingquan Ji, "Bidirectional Power Flow Z-Source DC-DC Converter," IEEE Vehicle Power and Propulsion Conference (VPPC), 2008, Harbin, China

Biography:



Shobhan babu.B received the B.Tech Degree in EEE from MITS Affiliated to JNTUH in 2009. He is currently pursuing M.Tech in ANURAG ENGG COLLEGE. Mobile: +91-9494347562 Email id: shoban204@gmail.com



B.Sreenu received B.Tech Degree in EEE from CJITS affiliated to JNTUH in 2005. Received M.Tech in PE from JNTUCEH in 2012. Working as an asst. professor in ANURAG ENGG COLLEGE. Mobile: +91-9848207493 Email id: sreenu777nits@gmail.com