

Analysis of Controller Effects of STATCOM on Power System during the Fault Condition

Bharat Thapa ^{#1}, T. Murali Mohan ^{#2}

[#]Department of Electrical and Electronics Engineering, Jawaharlal Nehru Technological University, Kakinada, AP, India.

¹ bthapa14@gmail.com

²tmmohan2009@gmail.com

Abstract— Due to increased demands and loads of different quality, electric power systems are growing highly unstable whose control is proving to be difficult. Reactive power compensation is done for the voltage stability and regulation in these power systems. Using FACTS (Flexible Alternating Current Transmission Systems) devices, fast dynamic control of voltage and phase angle of high voltage ac lines can be achieved. FACTS devices such as STATCOM (Static Synchronous Compensator) regulate to improve the voltage profile by dynamically absorbing or generating the reactive power during system faults. They have a faster response than conventional compensators. These devices are connected to the transmission line as shunt. In this paper, analysis of STATCOM effects on the voltage profile, active –reactive power on the different buses are done before and after the fault occurrence in the power system.

Index Terms— STATCOM, reactive power compensation, system fault, PSAT.

I. INTRODUCTION

A power system containing generators and different linear and nonlinear loads is highly unstable system. It is also non stationary system since the power network configuration changes continuously as the lines and loads are switched on and off [5]. The control of such system for the stability in the power network is especially done through the compensation of the reactive power. Reactive power causes an increase in the losses of the transmission systems, decrease in the energy capacity carried in the transmission line and changes in the voltage amplitude at the end of the line [4]. Hence it is necessary to provide reactive power compensation in order to increase transmitted power, decrease losses and provide stability of voltage amplitude at the end of the line. Reactive power compensation is used as an effective method to improve both transmission capacity and voltage stability [6].

The use of reactive power compensation devices are wide in practice to increase the transmittable power in the power system. It has been convincingly seen that the dynamic stability of the power system can be improved and the voltage profile can be maintained if the reactive power compensation of transmission line is made rapidly variable by using the solid

state devices i.e. FACTS devices [4]. FACTS devices can be effectively used for the control of power flows, providing the Possibility of operating the transmission grid with increased flexibility and efficiency [1]. The comprehensive devices that Originate from the FACTS technology are Static Var Compensator (SVC), Static Synchronous Compensator (STATCOM) and Unified Power Flow Controller (UPFC) [7]. In this paper, analysis of the system before and after the fault condition using the STATCOM reactive power resources connected to the transmission line in the 4 bus system is done. Power System Analysis Toolbox (PSAT) program was utilized to analyze voltage profile, active and reactive power capacity on the line.

II. SYSTEM CONFIGURATION

The system configuration for the analysis of the controller effects of STATCOM on the systems during the system faults conditions is represented by the general diagram as shown in Fig. 1. The system is a 4 bus, 11 Kv closed loop power network and is simulated using the MATLAB/PSAT toolbox. The primary function of STATCOM is to control the reactive power and hence the voltage profile at the point of common coupling. Fault is applied at bus 2 at the time $T=3$ sec and fault clearing time is $T=3.5$ sec. For the system security a circuit breaker with the intervention time $T=3.5$ sec is used.

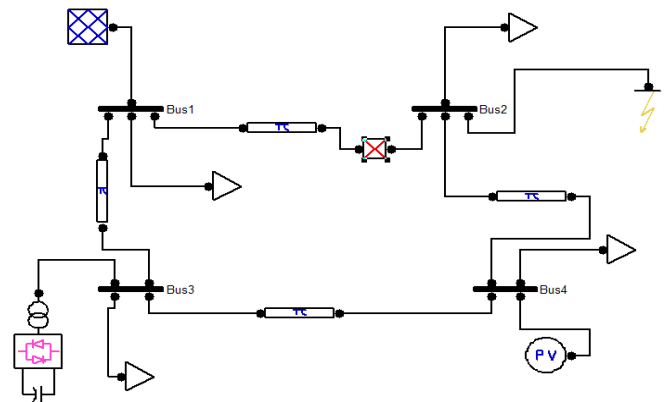

Fig 1: General diagram for the 4- bus system

The system is modeled in PSAT shown in Figure 1 and Figure 2 and 3 shows the network visualization of system with and without STATCOM.

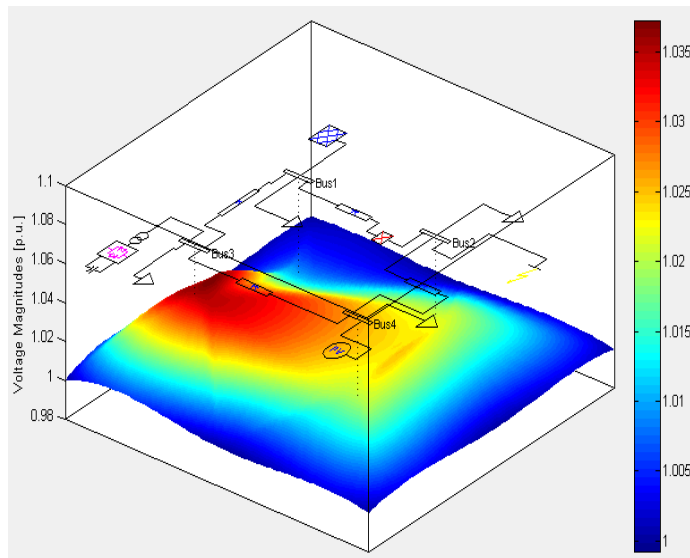

Fig 2: Network visualization of system with STATCOM

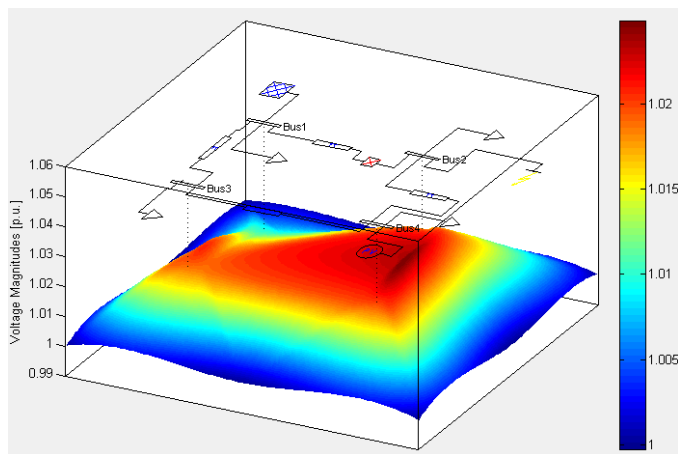

Fig 3: Network visualization of system without STATCOM

III. STATIC SYNCHRONOUS COMPENSATOR

The Static Synchronous Compensator (STATCOM) is a shunt connected reactive compensation equipment which is capable of generating and/or absorbing reactive power whose output can be varied so as to maintain control of specific parameters of the electric power system[2]. The STATCOM provides operating characteristics similar to a rotating synchronous compensator without the mechanical inertia [5]. Due to the STATCOM which employ solid state power switching devices provides rapid controllability of the three phase voltages, both in magnitude and phase angle [5]. The STATCOM basically consists of a step-down transformer with a leakage reactance, a three-phase GTO or IGBT voltage source inverter (VSI), and a DC capacitor. The AC voltage difference across the leakage reactance produces reactive power exchange between the STATCOM and the power system, such that the

AC voltage at the bus bar can be regulated to improve the voltage profile of the power system, which is the primary duty of the STATCOM. However, for instance, a secondary damping function can be added into the STATCOM for enhancing power system oscillation stability. The basic voltage-source converter representation for reactive power generation is shown schematically in Fig.4.

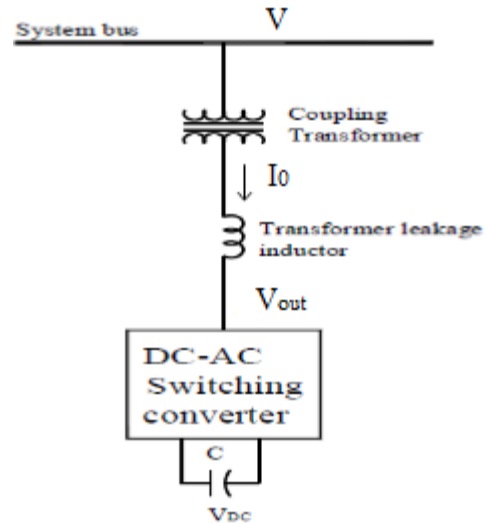

Fig 4: One line diagram of STATCOM [5]

During the faults condition the system current is large which affects the STATCOM performance resulting in the tripping of the devices [3]. Hence during and after the faults in the system it is realized that the VAR support functionality of STATCOM is required the most. V-I characteristics of STATCOM under non-stop functioning condition was given in the Fig. 5. The characteristics shows that the power system is provided with both inductive and capacitive flows in regular intervals.

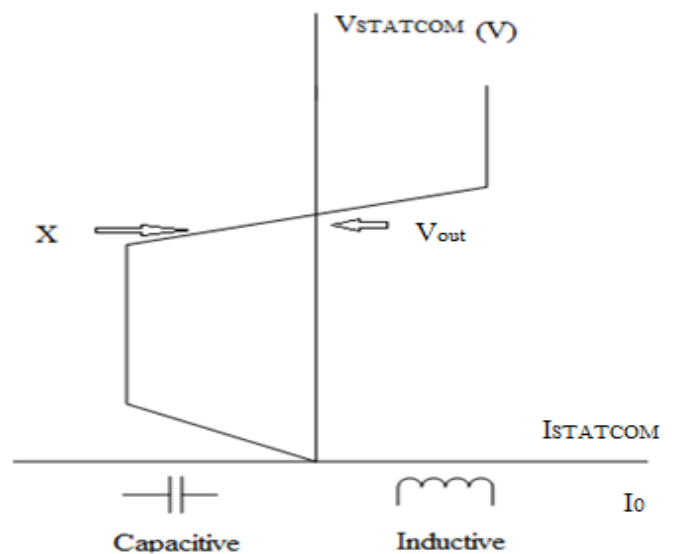

Fig 5: V-I characteristics of STATCOM

During the operation of STATCOM only the reactive power are generated and absorbed hence the system and the convertor output voltage are in phase when neglecting the circuit losses. Assuming the ac current flowing from convertor to the ac system the magnitude of the current is given by (1).

$$I_0 = \frac{V_{out}-V}{X} \quad (1)$$

Where X is the leakage reactance of coupling transformer. The corresponding reactive power exchanged is given by equation (2).

$$Q = \frac{V^2_{out}-V_{out}V\cos\alpha}{X} \quad (2)$$

If the inverter output voltage in the system is beyond compared to AC system voltage, the inverter will provide active power from DC capacitor to the AC system. If the inverter output voltage in the system is behind compared to AC system voltage, the inverter will extract active power from the AC system. The amount of active power exchanged constantly is rather small. The active exchange between voltage based inverter and AC system is given by Eq. (3).

$$P = \frac{V_{out} V \sin\alpha}{X} \quad (3)$$

IV. SIMULATION AND RESULT

This study conducted simulation practices on the 4 bus power system by utilizing the PSAT program. These practices were implemented based on the voltage profile on the system's load busses. Parameters used for the system and FACTS controllers were selected from the PSAT program. Fig. 1 displays the general structure of the 4 bus system that will be investigated.

A. Without STATCOM

First of all, a continuous power flow analysis for 4 bus system power system was undertaken in order to determine the voltage profile at different buses during and after the fault without the use of STATCOM in the system. The voltage profile of the system during the fault can be seen in Fig. 6. Fig 7 and 8 displays the real and reactive power profile at different buses when the STATCOM is not connected in the system. From this we can see the voltage dip in the bus 2 where fault have occurred and also the voltage dip can be seen at bus 3. The active and the reactive power flow at different buses can be seen. From this we can see that the active power at the bus 2 and bus 4 are maximum with respect to the other bus and active power is fully given by the bus 1. The reactive power is all negative i.e. the reactive power to the load is no avail and it can be verified from the Fig 8.

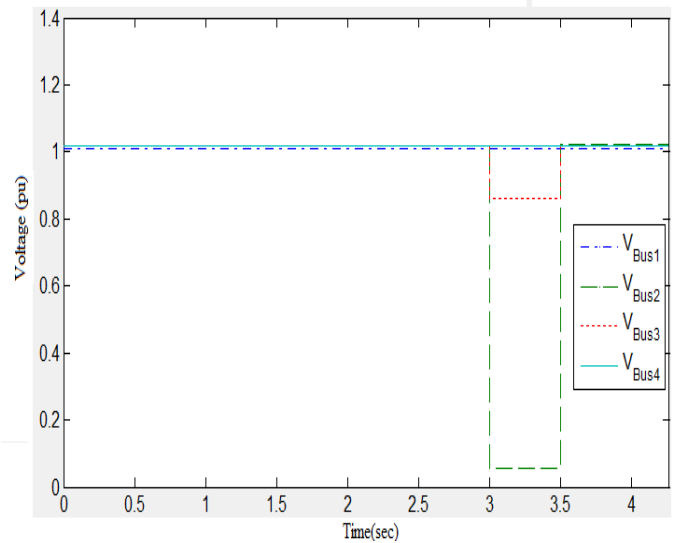

Fig 6: Voltage profile at different buses during fault without STATCOM in system

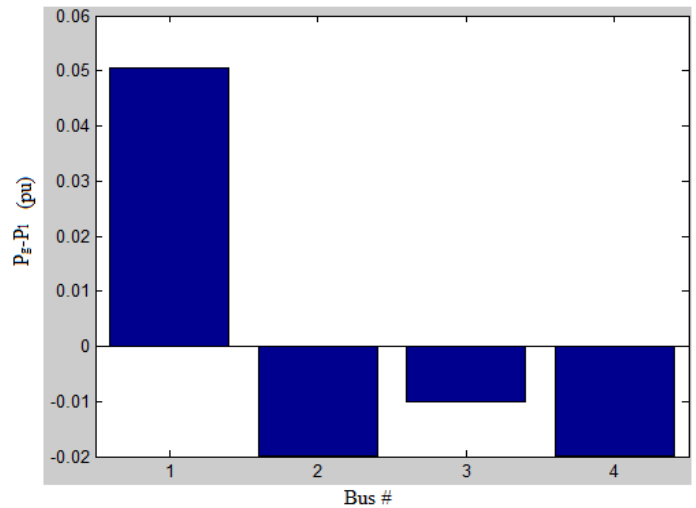

Fig 7: Real power profile at buses

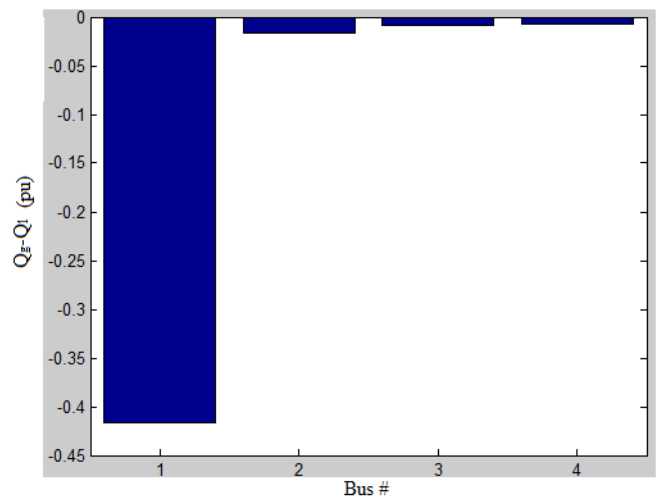

Fig 8: Reactive power profile at buses

B. With STATCOM

It was stated that bus identified as most critical in the system in terms of voltage stability needed enhancement work. In this case, another controller, STATCOM was added to the bus and load flow work was undertaken as seen in Fig.1. Table 1 provides the parameter values selected for STATCOM elements added to these bus.

Table 1: Parameter of STATCOM controller

S(MVA)	V(pu)	F (hertz)	K _r	T _r (s)	I _{max} -I _{min}
100	11	50	50	0.1	5-0.8

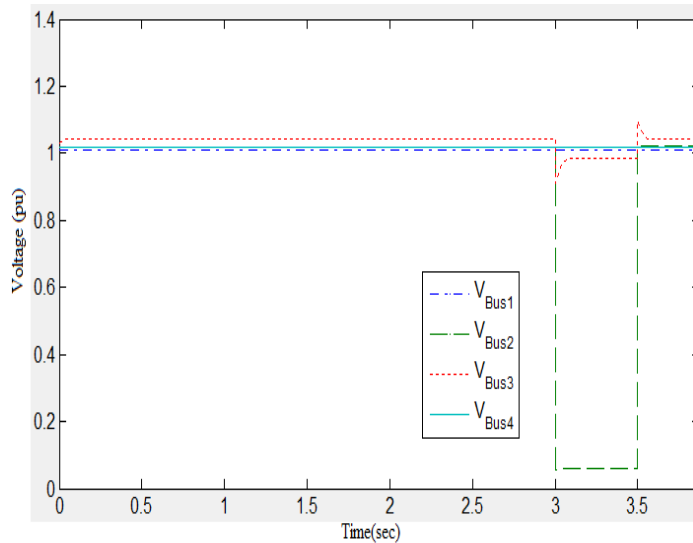

Fig 9: Voltage profile at different buses during fault with STATCOM in the system

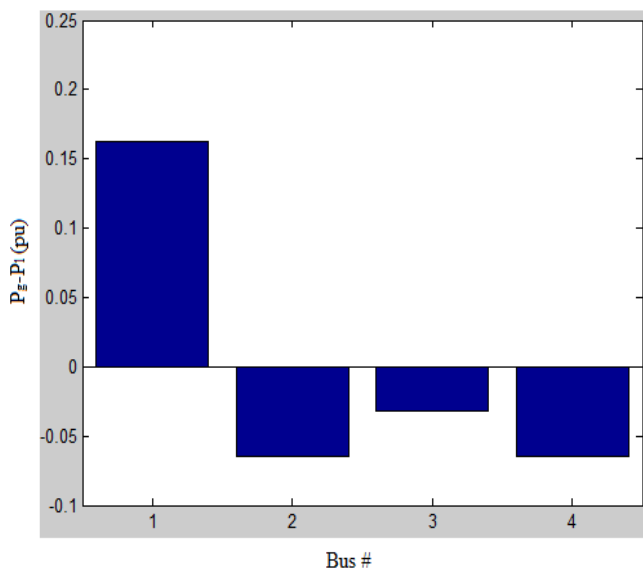

Fig 10: Real power profile at buses

Fig 9 shows the comparative summary of the changes in the voltage amplitude values in the studied 4- bus power system

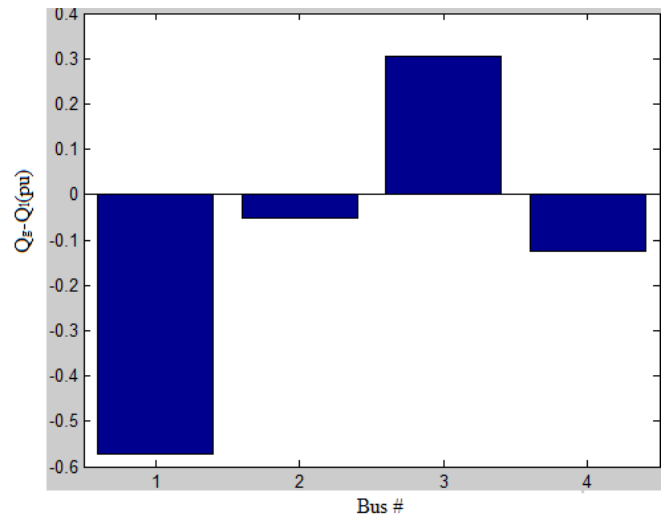

Fig 11: Reactive power profile at buses

and Fig 10 and 11 shows the transferred active and reactive power in the network. During the fault time the STATCOM maintain the voltage profile of the bus 3 in which it is connected. The reactive power is compensated by the STATCOM to the system in order to maintain the voltage profile. From the Fig. 11 we can see the reactive power compensated by the STATCOM on the system at bus 3.

The obtained results have shown STATCOM controllers increase the static loading limits in a power system. Hence, it can be said that the reliability levels of the system against voltage collapse are increased. In this system, voltage profile was maintained during the fault i.e. under voltage drop during the fault in the system is maintained. By the addition of STATCOM to the system, the system is injected with reactive Power.

V. CONCLUSION

Increasing energy demand has necessitated the development of new electric energy production resources. Currently, reactive power compensation elements FACTS (Flexible Alternating Current Transmission Systems) devices have been used [5]. The FACTS devices include power electronics components. They have a faster response than conventional compensators. In this study, STATCOM (Static Synchronous Compensator) that are known as the FACTS devices are used. The effects of FACTS devices on the voltage profile, active –reactive power in the system buses were investigated.

ACKNOWLEDGEMENT

The author wish to thank to everyone who have directly or indirectly supported for the completion of the work. Their valuable comments and suggestion has greatly improved the quality of paper.

REFERENCES

- [1] Y. Suresh, A.K Panda, "Dynamic performance of STATCOM under line to ground faults in power system," *5th IET international conference*, Brighton, UK, April 2010, pp. 1-6.
- [2] Fathi M. H. Youssef, E. A. Badran, S. Abulanwar. Dynamic performance comparison between STATCOM and SVC. *OJEEE* [online], pp. 425- 429 Available: <http://infomesr.org/en/scientific-research/journals/current-journals/21-ojeee>.
- [3] Su Chen, Geza Joos, Luis T. Moran, " Dynamic performance of PWM STATCOM operating under unbalance and fault condition in distribution systems", *Power Engineering Society Winter Meeting IEEE (Vol. 2)* , Columbus ,OH, Jan- Feb 2001,pp. 950-955.
- [4] Laszlo gyugyi, "Dynamic Compensation of AC Transmission Lines by Solid State Synchronous Voltage Sources", *IEEE transaction on power delivery*, Vol. 9, No. 2, April 1994.
- [5] Narain G. hingorani , Laszlo gyugyi, "Understanding FACTS Concepts and Technology of Flexible AC Transmission Systems", Wiley publication,2000.
- [6] Salih tosan, "Investigation Of Controllers Effects of Svc and STATCOM on Power System", *Energy Education Science and Technology part A: Energy Science and Research*,Vol. (issue)29 (2),2012, pp. 749-760.
- [7] Anirudh dube, P. R. Sharma, "Dynamic Stability Improvement and Real Power Losses Reduction of a Multi Machine Power System Using Unified Power Flow Controller", *International Journal of Power System Management and Energy Management*,Vol. (issue) 1 (4), 2012.



Bharat Thapa, born in 1987, completed his Bachelor in Electrical and Electronics engineering specialization in Power and Control from Kathmandu University, Nepal. He is currently pursuing his M. Tech degree from Jawaharlal Nehru technological university, Kakinada, A.P., India. His field of interest includes renewable energy, power system analysis.



Thenepalli Murali Mohan, born in 1975, completed B. Tech from S. V. University, Tirupati in 1999 and completed M. Tech from IIT Madras in 2001. He has 12 years of teaching experience both at under and post Graduate levels. Currently he is working towards his doctoral degree. His research interest includes renewable energy sources and power system deregulation.