

# GAIN FLATTENING OF EDFA USING GFF

Warsha Balani<sup>#1</sup>, Prof Manish Saxena<sup>\*2</sup>

<sup>#</sup>EC Deptt, R.G.P.V Bhopal  
Mtech Student B.I.S.T Bhopal

<sup>1</sup>balani.warsha@gmail.com

<sup>\*</sup>EC Deptt, R.G.P.V Bhopal  
Assistant Prof B.I.S.T Bhopal

<sup>2</sup>manish.saxena2008@gmail.com

**Abstract**— In this paper we optimise the gain of the 8 DWDM channel over entire conventional band i.e. C band .EDFA has high gain, large bandwidth, low noise but has uneven gain[1]. This unevenness reduces the transmission bandwidth and degrades the performance of system [1]. The gain flattening is done with the help of the Gain Flattening Filter (GFFs). We approach to the external modulation in the proposed model. Numerical simulation result shows that this technique can minimise unevenness up to 0.05dB gain from 23.48 to 23.43dB in all the prescribed channels.

**Keywords**— EDFA, gain flatness, Gain Flattening Filter (GFFs).

## I. INTRODUCTION

Erbium doped fiber amplifiers have had a major impact in the field of light wave communications. Optical amplifiers have contributed to the growth of a fifth generation of optical communication systems. But as the demands on the networks increased techniques like Dense Wavelength Division Multiplexing (DWDM) were developed. The performance of DWDM in ultra-long haul networks improved because of the fact that amplifiers were available that could amplify the wavelengths used in the network without requiring any conversion of the optical signal to the electrical signal. The importance of EDFA's is due to their compatibility with the fiber network, low insertion loss, polarization insensitivity, high gain levels and near quantum limited noise performance[4].

In DWDM transmission systems and their related optical networks, one of the key technological issues is the achievement of broad and flat gain bandwidth for Erbium Doped Fiber Amplifiers(EDFA's). Gain differences occur between optical channels having large wavelength spacing (e.g.  $\Delta\lambda > 1\text{nm}$ ). In long amplifier chains, even small spectral gain variations (e.g.  $\Delta G < 0.75$

dB) can result in large differences in the received signal power, causing unacceptably large BER discrepancies between received signals[4]. For some optical channels, complete power extinction can occur at the system output, due to insufficient gain compensation along the amplifier chain. Additionally, the ASE generated in the region of highest gain (i.e., near  $\lambda = 1530\text{ nm}$ ) in unequalized EDFAs causes homogenous gain saturation, which affects WDM channels at longer wavelengths[1].

Uniformity of gain involves two aspects, namely gain equalization and gain flattening. Gain equalization means achieving identical gains for a discrete number (two or three) of optical channels. Gain flattening means achieving a spectrally uniform gain bandwidth. Gain equalization can be achieved with requiring gain flattening. For example, given an EDFA of length L, the pump power can be chosen such that the gains at two different wavelengths become exactly equal due to signal re-absorption at short wavelengths. This method though useful does not work under saturated operating conditions. Later methods to flatten the gain using hosts such as fluorozirconate glass were investigated. It was found that the gain spectrum for these fibers though more uniform did not provide high pump efficiency. Therefore, these methods were not investigated any further.

## A) TECHNICAL BACKGROUND OF EDFA

The routines in EDFA numerically solve the rate equations coupled with propagating equations under stationary conditions. It is assumed a two-level Er system approximation and the rate equations are based on the energy level diagram. The same expressions described in the module Erbium Doped Fiber are adopted by this model. The main difference is related to the amplifier pump scheme selection. You can choose co-propagating, counter-propagating, or bi-directional pump schemes with the option to set wavelength and pump power. Geometrical Er-doped fiber

parameters and cross-section curves are required as input files. As output files, you can access gain, output power values, and noise figure determined in the ASE bandwidth set as noise input data.[5]

**B) ERBIUM DOPED FIBER RATE AND PROPAGATION EQUATIONS**

The lifetime transition from level 4I11/2 is of the order of microseconds for silicate hosts. Therefore, it is reasonable to neglect the population density N3 in the rate equations description. A two-level system approximation is used in this case. Under the assumption of the normalized population densities N1 and N2 at the ground and metastable energy level, 4I15/2 and 4I13/2 populations are calculated by numerically solving the rate and propagation equations[1]:

$$\frac{\partial N_2(z,t)}{\partial t} = -\frac{N_2(z,t)}{\tau} - \frac{1}{A_{eff}} \sum_{n=1}^N \{ \Gamma_n [(\sigma_n^e + \sigma_n^a) N_2(z,t) - \sigma_n^a] \} [p_n^+(z,t) + p_n^-(z,t)] \dots \dots \dots 1$$

$$N_2 + N_1 = 1$$

$$\frac{\partial p_n^\pm(z,t)}{\partial t} = u_n \{ \rho \Gamma_n [(\sigma_n^e + \sigma_n^a) N_2(z,t) - \sigma_n^a - \alpha] \} [p_n^\pm(z,t) + 2\rho \Delta v N_2 \Gamma_n \sigma_n^e] \}$$

where the optical powers are expressed in units of number of photons per unit time,  $\tau$  is the metastable spontaneous emission lifetime, N is the number of channels taken into account in the simulation (including signals, pumps, and ASE bins),  $\rho$  is the number density of the active erbium ions,  $\alpha$  is the attenuation coefficient (which takes into account the background loss of the fiber),  $\Delta v$  is the frequency step used in the simulation to resolve the ASE spectrum, and  $A_{eff}$  is the effective doped area given by  $\pi b^2$ , where  $b$  is the Er doping radius (it is considered a uniform distribution of erbium ions in the area given by the Er doping radius region). The  $n$ th channel of wavelength  $\lambda_n$  has optical power  $P_n(z,t)$  at location  $z$  and time  $t$ , with emission and absorption cross-section  $\sigma_n^e$  and  $\sigma_n^a$  respectively, and confinement factor  $\Gamma_n$ . The superscript symbols + and - are used to indicate channels traveling in forward (from 0 to L) and backward (from L to 0) directions, respectively. For beams traveling in the forward direction  $u_n = 1$  and for beams in the opposite direction  $u_n = -1$ . The overlap integrals between the LP01 mode intensity (which is used in this program) distribution doped region area are given by:

$$\Gamma_n(v) = \frac{\int_0^\infty |E(r,v)|^2 r dr}{\int_0^\infty |E(r,v)|^2 r dr}$$

Where  $E(r,v)$  gives the electric density field.[5]

**C) THEORETICAL ASPECT OF GAIN FLATTENING FILTER (GFF)**

Gain Flattening Filter (GFFs), also known as gain equalizing filters, are used to flatten or smooth out unequal signal intensities over a specified

wavelength range. This unequal signal intensity usually occurs after an amplification stage (e.g., EDFA and/or Raman). Typically, GFFs are used in conjunction with gain amplifiers to ensure that the amplified channels all have the same gain.

The quality of a GFF is best described by the peak-to-peak error function (PPEF) because it represents the maximum flatness of the transmitted signal. The PPEF is calculated by comparing the spectral performance of the manufactured filter to the target curve specification. In general, the factors that determine the minimum PPEF that can be achieved are the maximum slope and the smoothness of the target curve. Some applications require multiple flattening regions or the addition of pass band outside the flattening region; these may increase the complexity of the filter. The wavelength domain specified in the gain equalizing target typically defines the operating range  $[\lambda_{Start}, \lambda_{End}]$ [6].

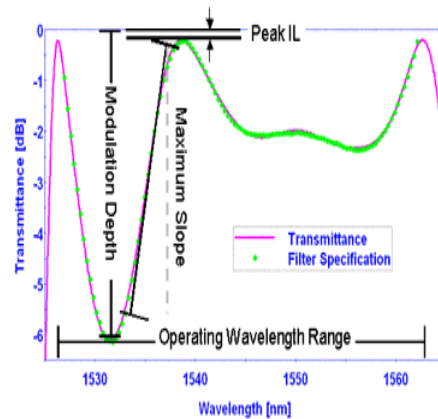

Fig. 1(a). Gain equalizing target curve

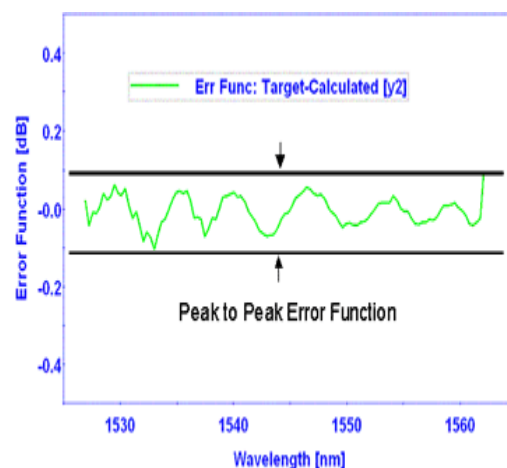

Fig. 1 (b) Peak to Peak error function

**II. II SET-UP MODEL**

Our proposed model is shown in the figure which consists of the WDM transmitter having the

frequency of the 1525 nm with the spacing of the 5 nm at -20 dB power. The signal is then routed to the WDM MUX whose properties are almost same

WDM MUX receives the signal at the ONU side after passing through the GFF. The property of the ONU WDM DMUX is similar to the transmitter.

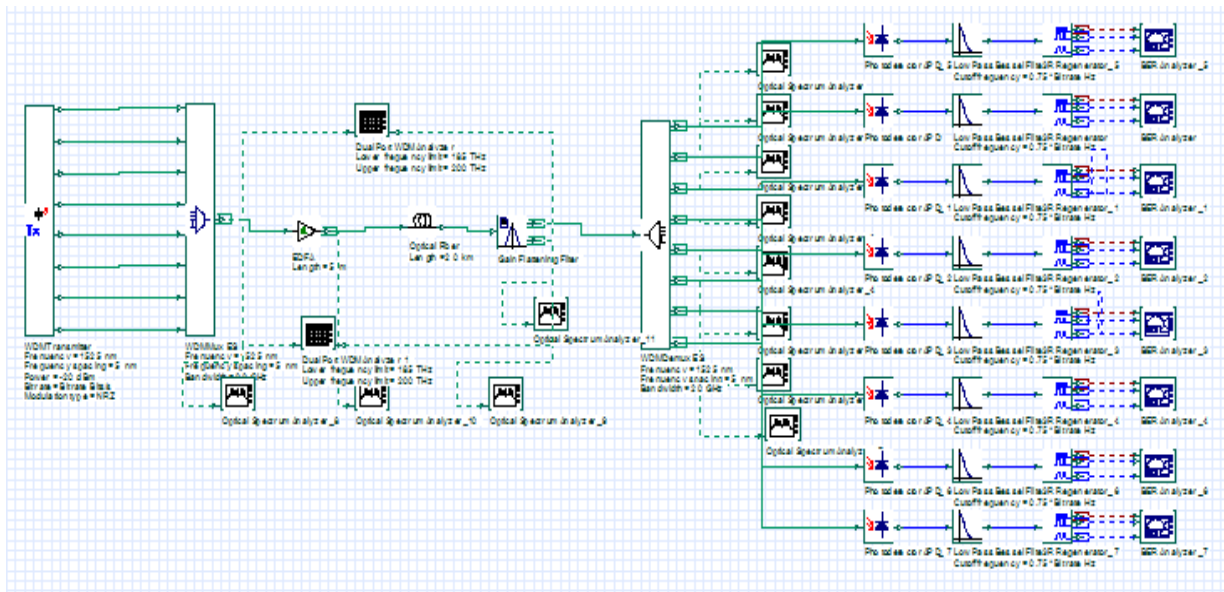

to that of the WDM transmitter having the bandwidth of 10 GHz. The signal is then passed through the optical fiber through the EDFA. The

Finally the signal is retrieved by the photo detector. The proposed model is shown in the fig2

Fig 2 Set up Model

III. RESULT AND ANALYSIS

The under mentioned figure demonstrate the uneven gain of the conventional amplifier due to the non linear effect, which is responsible for the reducing the performance of the leading devices connected in the network. So in order to enhance the performance its important to flat the gain of the amplifier. This gain flattening is possible with the help of the GFF(Gain Flattening Filter).

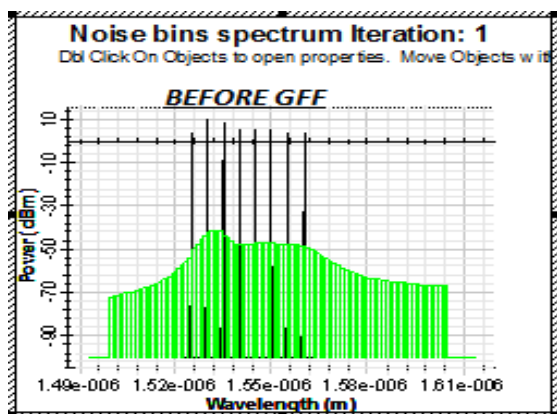

Fig. 3(a). Gain before GFF.

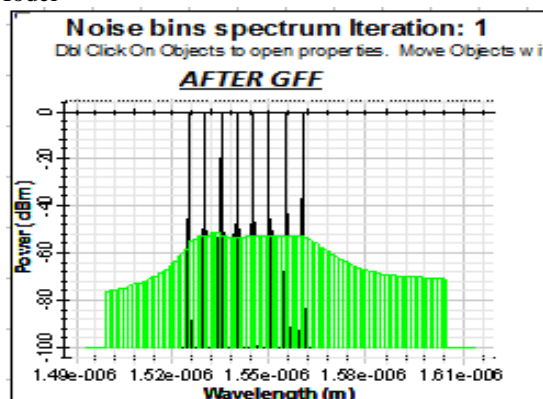

Fig. 3(b). Gain after GFF.

As the signal passes through the GFF the gain of the amplifier is flattened due to reduction in the uneven signal intensity over a specified wavelength range. The aspect is fully cleared with the help of the fig.3(a,b). The first figure shows the gain variation before passing through the GFF, where as fig 3.b shows the equilised gain after passing through the GFF.

The spectrum of the GFF is demonstrated in the fig. 4 which is just opposite of the ASE generated by the conventional EDFA in order to compensate the unequal variation in the channels gain

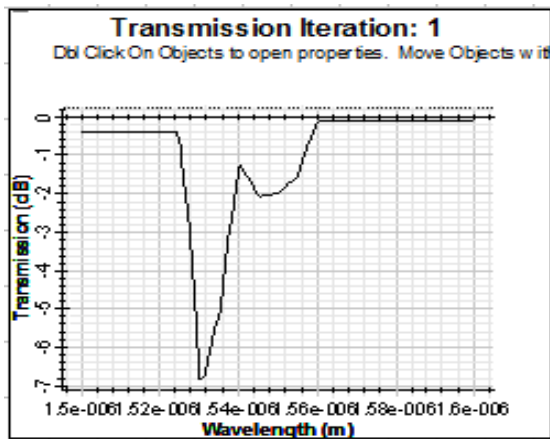

Fig. 4. GFF spectrum.

The typical plotting of the graph between the gain and wavelength after GFF is shown in the fig.5. As from the figure it is clear that the gain of the channels is almost flat ranging from 1525 to 1560 nm which is the range of the conventional band. where as a small spike of .4dB at 1530 nm wavelength is shown in fig 5.

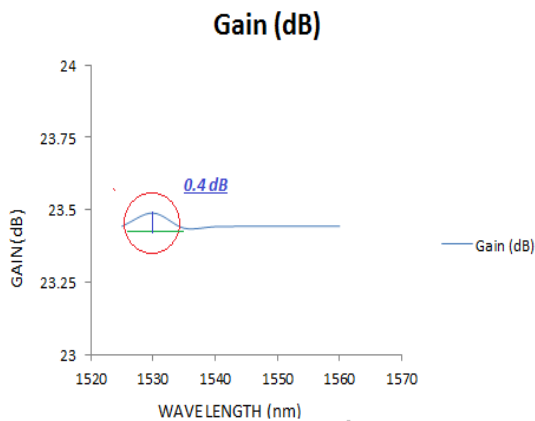

Fig. 5. Gain v/s wave-length plotting.

A band of spike is visible at the range of 1530 to 1540 nm wavelength due to the ASE of the EDFA. The fig.6 is the plotting between the output noise and the wavelength of the over all system. This spike is responsible for producing the variation of 0.4 dB at 1530 nm wavelength from the other wavelength ranging from 1525 to 1560 nm.

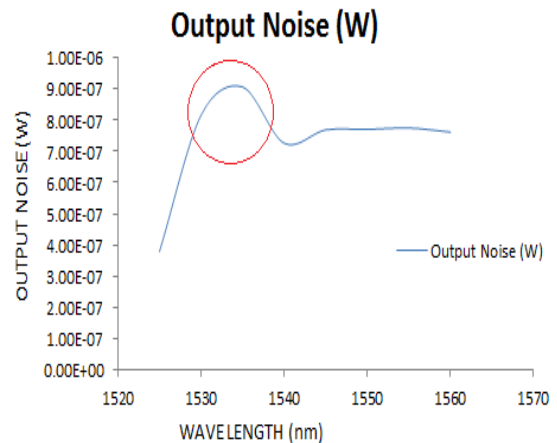

Fig. 6. Output noise v/s wavelength plotting.

#### IV. CONCLUSIONS

In this paper a attempt is made theoretically to flattened the gain of the EDFA which is the vital issue in the DWDM long haul communication. In our proposed design we optimised the GFF to achieve 23.45 dB gain in all associated channels. From the simulation study it is quite clear that the transmission spectrum. of the GFF is complimentary to the ASE of the EDFA. The uneven gain of the EDFA is 0.4 dB due to the ASE of the EDFA

#### ACKNOWLEDGMENT

This research project had been carried out in the Optical communication laboratory under the Dept. of Electronics and Communication, BIST Bhopal. All authors and co-authors are contributed in this project.

#### References

- [1] Liu Kaixian, Du Juan “research of edfa gain flattening based on chirped fiber Bragg grating” *Proceedings of IC-BNMT2009*, IEEE.
- [2] C. M. de Sterke and J. E. Sipe, “Gap Soliton”, in *Progress in optics*, 1994, vol. XXXIII, pp.203-260, E.Wolf, Ed., North-holland, Amsterdam.
- [3] Turan Erdogan, *Fiber Grating Spectra*, Journal of Lightwave technology, 15(8):1277-1294, 1998.
- [4] S. Vikra, K. Thyagarajan “A New Design for a gain flattened Erbium Doped Fiber Amplifier” Dept. of Physics, Indian Institute of Technology Delhi, 2010.
- [5] C.R. Giles and E. Desurvire, “Modeling erbium-doped fiber amplifiers,” *Journal of Lightwave Technology*, Vol. 9, N. 2, pp. 271-283, 1991.
- [6] <http://www.lightwaves2020.com/products/tffcoating/gfffilters.asp>
- [7] U-V Photo-induced fiber gratings of gain equalization, I.Riant, *J Optical Fiber Technologies* (2002).171-194.