

# An Intelligent Robot for Bomb Detection with Wireless Video Transmission

Babul Kumar, Debadas Khuntia, Chhote Lal Kumar Ram

Department of Electrical And Electronics Engineering

Bharath Institute of Science and Technology

Chennai-600 073, India

babul\_kuma35@yahoo.com

1

Under the SuperVision of-

S.P.VIJAYARAGAVAN, Asst. Prof., Bharath University, Chennai-600073

**Abstract**— This paper proposes a surveillance system in the form of robot designed with the help of a micro-controller for remotely controlled operation using Zig-Bee communication established between robot and the host pc in a range of 100 meters and equipped with wireless video footage transmission using RF signal for live video at 25-30 frames per second. In the real time application, the detection of bomb is one of the tough and risky task for human life. In order to eliminate this, this paper introduces a ROBO on the plate-form of Embedded System.

**Keywords**— Intelligent Robot, Bomb Detection Robot, Zig-Bee Surveillance vehicle

## I. INTRODUCTION

There are a lot of application of robot in the real time ranges from pick-place to bomb detection, chemical handling to electronic assembly, and metal welding to mine finding and a lot more. The mechanism of all these robots are almost same, only in variance with its programming part. Furthermore, each robot manufacturer provides its unique coding according to its application. MPLAB, the software used to program the micro-controller, is a well-known software. In the proposed robot, we are using PIC 16F877A as a micro-controller.

### A. ROBOT UNIT

The robot vehicle is relatively lightweight and its chassis is designed to accommodate most of the weight at the lowest possible point in the body in. The articulated arm of the robot-unit is placed on the top-deck of the vehicle and it is uniquely shaped in order to support the module which is capable of moving in vertical direction. There is a communication link between master control unit and robo-unit via Zig-Bee Link.

Though it is a Bomb detection Robot, but the real time bomb sensor is not used because of the variable composition of bomb material, a metal sensor or magnetic sensor can be used as a proto-type and can be replaced by a real bomb sensor if used practically widely for the purpose. The robot unit packs of four DC motors(2 for wheel and 2 for arm), one 8-bit PIC micro-controller, a wireless camera, motor driver circuitry to control and drive the motors and Zig-Bee modem Circuitry to transmit and receive signal being send by master control unit or by the micro-controller. There are two motor driver circuit,

one for the wheel movement control and one for the vertical movement control.

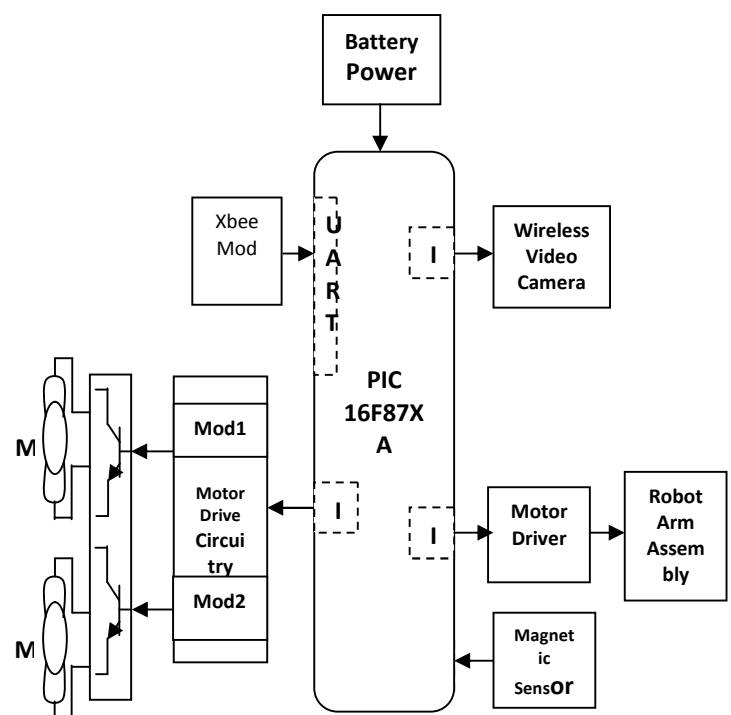

Figure 1 Robot Unit

### B. CONTROL UNIT

The control unit comprises of a PC, a GUI interface software, a Zig-Bee R<sub>x</sub>-T<sub>x</sub> duplex communication modem, a level converter which converts host computer control signal to Zig-Bee compatible signal and a driver interface card. A wireless RF receiver is used to receive the footages send by the camera placed on the robot unit to visualize the live video of the place where the robot is present. Using a driver interface card, the can be seen on the host PC or can be directly seen on a television without using any interface card. Though the PC does not understand the signal received by Zig-Bee, we use Level-Converter in between PC and modem

to change the level of signal and make the signal PC acceptable.

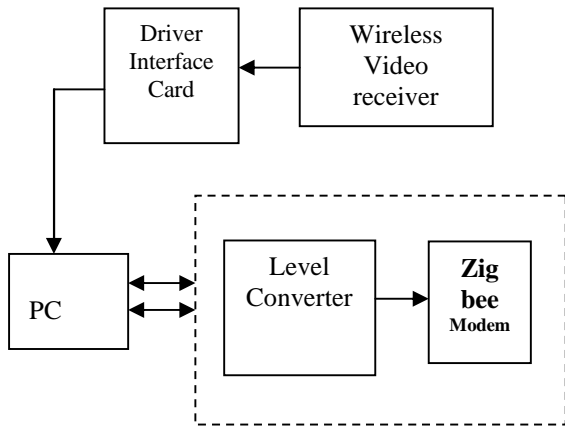

FIGURE 2 CONTROL AND MONITORING UNIT

The detailed explanation of each unit of robot and control circuit is being explained in next sections with the underwired plate-form.

II. ZIG-BEE COMMUNICATION LINK

In the proposed paper, Zig-Bee are standard protocol used to establish a network infrastructure required for wireless sensor networks. Due to its low cost, high performance, small foot print, reliable and self healing, global with use of unlicensed radio band, security purposes, flexible and extendable, integrated intelligence for network set-up and message routing and low power consumption, it is widely used now a days for wireless network establishment.

There are numerous applications that are ideal for the redundant and self-configuring capabilities of Zig-Bee wireless mesh networks. It is mainly used in Home Automation, Industrial Automation, Energy Management and Efficiency.

It provides the interface to the physical transmission medium as radio. There are two types of frequency used in Zig-Bee. The lower frequency physical layer covers both the 868MHz European band and the 915MHz band used in countries such as the US and Australia. The higher frequency physical layer (2.4GHz) is used virtually worldwide.

ZigBee networks include the following device types:

A. Coordinator

This device starts and controls the network. The coordinator stores information about the network, which includes acting as the Trust Center and being the repository for security keys.

B. Router

These devices extend network area coverage, dynamically route around obstacles, and provide backup routes in case of device failure or network congestion. They can connect to the coordinator and also support child devices.

C. End Devices

These device transmits or receives a message, but it cannot perform any routing operations. They must be connected to either a router or the coordinator, and do not support child devices

Features	XBee	XBee-PRO
* Range - Indoor	100ft (30m)	300 ft (100m)
*Range – Outdoor	300ft (100m)	1mile(1500m)
Transmit Power	0dBm(1mW)	20dBm(100mW)
Receiver Sensitivity	-92 dBm	-100 dBm
214mA	TX Current	45mA
RX Current	50mA	55mA
Power-Down (Sleep) Current	<10uA	<10uA

\* Ranges are line of sight and height dependent

Table I XBee Features

Supply Voltage	2.8 - 3.4 V
Transmit Current	45 mA (@ 3.3 V)
Receive Current	50 mA (@ 3.3 V)
Serial Data Interface	3V CMOS UART
Size	0.960" x 1.087" (2.438 cm x 2.761 cm)
Weight	0.10 oz (3g) - w/ U.FL. connector
Antenna Options	U.FL. RF connector, chip antenna, or whip antenna
Operating Temp.	-40 to 85° C (industrial)

Table II Power and Physical Properties

In the proposed paper, XBee operating voltage is 3.3V which is being converted from 5V using a voltage regulator and R<sub>x</sub>-T<sub>x</sub> port of XBee is connected to UART terminal of micro-controller.

III. MICRO-CONTROLLER

Micro-controller used here is PIC 16F877A which is preferable due to its best performance, high speed, accuracy and choices of data transfer protocol. This highly dense integrated chip is compatible with most of the devices and network and so as easily accessible at low cost. The operating voltage of this chip is 5V which is obtained with the help of 7805 voltage regulator IC. The earlier, it was known as micro-computer because it contains both processor and peripheral. A micro-controller exhibits of many blocks such as Memory Unit, Central Processing Unit, Bus, Io Terminals, Timers,

Serial Communication (UART,I2C), Watch dog and AD converter.

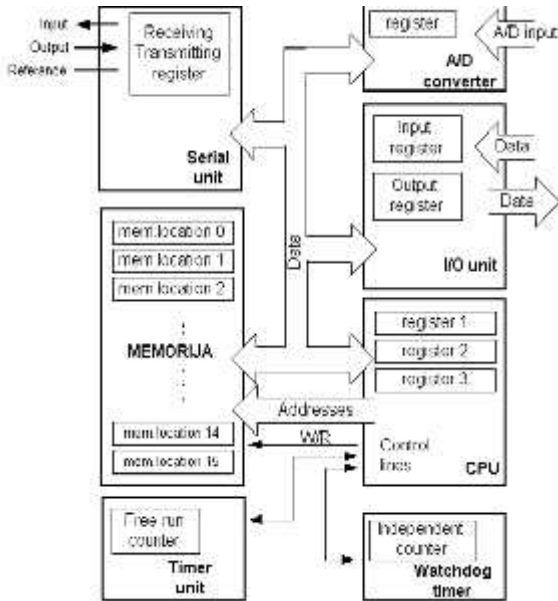

Figure 3 Microcontroller with its basic elements and internal connections

A. PIC Microcontroller (PIC16F877X) Microcontroller Core Features:

- High-performance RISC CPU
- Only 35 single word instructions
- All single cycle instructions except for program branches
- Operating speed: DC - 20 MHz clock input DC - 200 ns
- Up to 8K x 14 words of FLASH Program Memory, Up to 368 x 8 bytes of Data Memory (RAM) Up to 256 x 8 bytes of EEPROM data memory
- Interrupt capability (up to 14 sources)
- Eight level deep hardware stack
- Direct, indirect and relative addressing modes
- Power-on Reset (POR)
- Power-up Timer (PWRT) and Oscillator Start-up Timer
- Watchdog Timer (WDT)
- Programmable code-protection
- Power saving SLEEP mode
- Selectable oscillator options
- Low-power, high-speed CMOS FLASH/EEPROM
- Fully static design
- In-Circuit Serial Programming (ICSP) via two pins
- Single 5V In-Circuit Serial Programming capability
- In-Circuit Debugging via two pins
- Processor read/write access to program memory
- Wide operating voltage range: 2.0V to 5.5V
- High Sink/Source Current: 25 mA
- Commercial and Industrial temperature ranges
- Low-power consumption:
  - < 2 mA typical @ 5V, 4 MHz
  - 20 mA typical @ 3V, 32 kHz
  - < 1 mA typical standby current

The clock pulse is given to the PIC using a Crystal Oscillator. The PIC16F87XA can be operated in four different oscillator

modes. The user can program two configuration bits (FOSC1 and FOSC0) to select one of these four modes:

- LP Low-Power Crystal
- XT Crystal/Resonator
- HS High-Speed Crystal/Resonator
- RC Resistor/Capacitor

IV. POWER CIRCUIT

A power supply provides a constant output regardless of voltage variations. "Fixed" three-terminal linear regulators are commonly available to generate fixed voltages of plus 3 V, and plus or minus 5 V, 9 V, 12 V, or 15 V when the load is less than about 7 amperes. In this circuit, the required power is 5V for micro-controller and motor driver IC ,3.3V for Zig-Bee and 6V for motors.

The "78xx" series (7805, 7812, etc.) regulate positive voltages while the "79xx" series (7905, 7912, etc.) regulate negative voltages. Often, the last two digits of the device number are the output voltages; eg, a 7815 is a +15 V regulator, while a 7905 is a -5 V regulator. The 78xx series ICs can supply up to 1.5 Amperes depending on the model

power supply

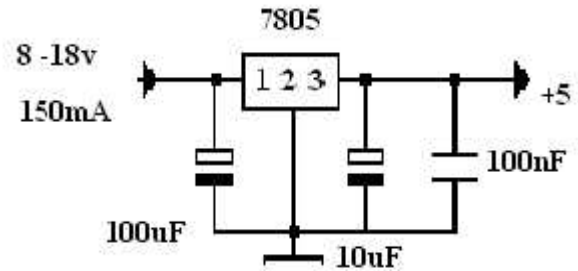

Figure 4

This circuit used is a small +5V power supply, which is useful when experimenting with digital electronics. This circuit can give +5V output and about 150 mA current, but it can be increased to 1 A when good cooling is added to 7805 regulator chip. The circuit has over overload and thermal protection.

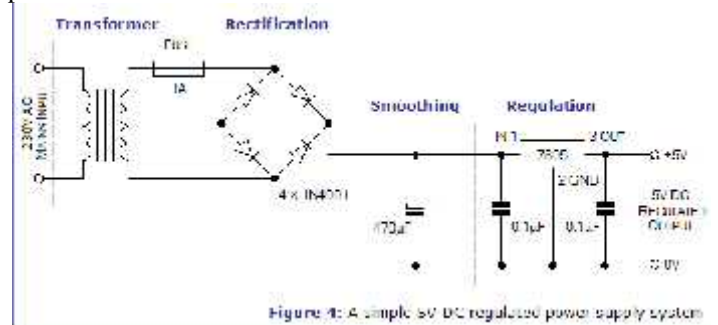

Figure 4: A simple 5V DC regulated power supply system

Figure 5

Thus, the Power supply is given to the circuit by 230V AC for Control unit and via 6V battery in Robot unit.

V. MOTOR DRIVER CIRCUIT TO DRIVE DC MOTOR

The L293D motor driver IC is designed to provide a bidirectional drive currents of up to 600mA at voltages from 4.5 V to 36 V. Devices are designed to drive inductive loads such as relays, dc and bipolar stepping motors, as well as other high-current/high-voltage loads in positive supply applications. All inputs of it are TTL compatible. Each output is a complete totem pole driver with a Darlington transistor sink and a pseudo-Darlington source.

A. Features of L293D

- Wide Supply-Voltage Range: 4.5 V to 36 V
- Separate Input-Logic Supply
- Internal ESD Protection
- Thermal Shutdown
- High-Noise-Immunity Inputs
- Output Current 1 A Per Channel (600 mA L293D)
- Peak Output Current 2 A Per Channel (1.2 A L293D)
- Output Clamp Diodes for Inductive Transient Suppression (L293D)

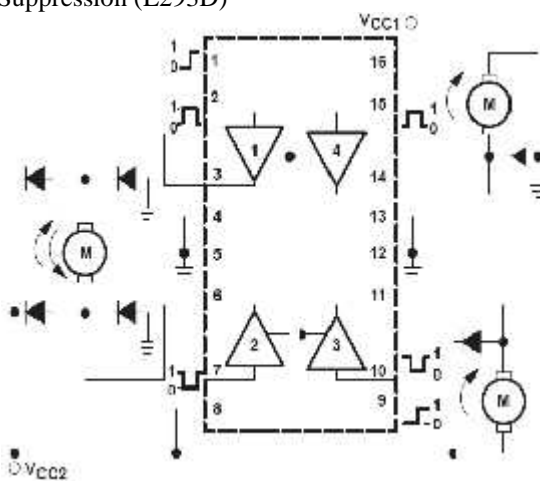

Figure 6 Block Diagram of L293D motor driver IC

B. Model of DC Motor

To be modeling a DC Motor, simple circuit of its electrical diagram. is considered. To Simulate the DC motor, the following steps are to be made step by step;

Step1:To perform the simulation of the system, an appropriate model needs to be established. Therefore, a model based on the motor specifications needs to be obtained

Step2: The motor torque T is related to the armature current, i, is given by a torque constant K;

$$T = K_i$$

The generated voltage is relative to angular velocity by;

$$e_a = k_m$$

DC Motors can rotate in two directions depending on polarity of the battery connected to the motor. Both the DC motor and the battery are two terminal devices that has positive and negative terminals. In order run the motor in the forward direction, connect the positive motor wire to the positive battery wire and negative to negative. However, to run the motor in reverse just switch the connections; connect the positive battery wire to the negative motor wire, and the negative battery wire to the positive motor wire. An H-Bridge circuit allows a large DC motor to be run in both directions

with a low level logic input signal.

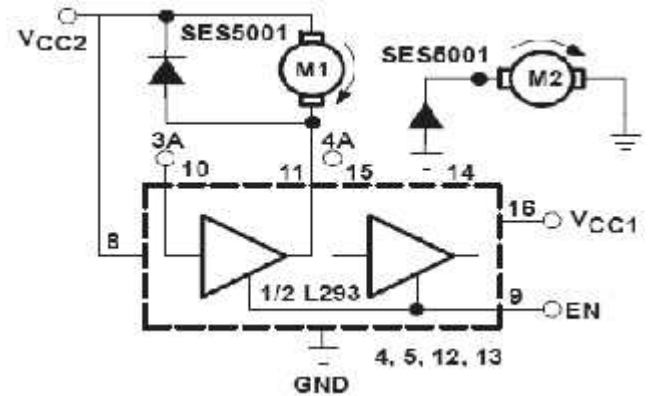

Figure 7 Connection to DC Motor

VI. WIRELESS CAMERA

To visualize the live environment around the robot, a wireless mini RF camera is used. There are two units of Camera, receiving unit and transmitting unit. Transmitting unit contains of camera with a RF transmitter and Receiving unit compromises with an RF antenna and a signal processing driver unit. In addition to that if we use PC to watch the footages, an additional Driver Interface Card will come into the picture to change the signal level to PC compatible.



Figure 8 Wireless mini camera

A. Technical parameters of transmitting unit:

- Size: only 38x25x16mm
- Video Camera Parts: 1/3CMOS, 1/4 Image Sensors
- System: PAL/CCIR NTSC/EIA
- Horizontal Definition: 380 Lines
- Scanning Frequency: PAL/CCIR: 50Hz, NTSC/EIA: 60Hz
- Minimum Illumination: 3 LUX Sensitivity: +18DB-AGL
- Electrical Level Output: 50mW
- Frequency Output: 1.2Ghz
- Transmission Signal: Audio, Video
- Linear Transmission Distance: 50-100m
- Voltage: DC+9V
- Current: 300mA
- Power Dissipation: 640mW

B. Technical parameter of receiving unit:

- Wireless Audio/Video Receiver
- Receiving Method: Electronic Frequency Modulation
- Reception Sensitivity: +18dB
- Receiving Frequency: 1.2Ghz
- Receiving Signal: Audio, Video
- Voltage: DC+12V
- Current: 500mA

VII. ANALOG TO DIGITAL CONVERTER

In this paper, ADC is used as a magnetic sensor specifically and it is also integrated with the micro-controller used. An analog-to-digital converter (abbreviated ADC, A/D or A to D) is an electronic integrated circuit, which converts continuous signals to discrete digital numbers. The reverse operation is performed by a digital-to-analog converter (DAC). A successive-approximation ADC uses a comparator to reject ranges of voltages, eventually settling on a final voltage range. Successive approximation works by constantly comparing the input voltage to the output of an internal digital to analog converter until the best approximation is achieved. At each step in this process, a binary value of the approximation is stored in a successive approximation register (SAR). The SAR uses a reference voltage (which is the largest signal the ADC is to convert) for comparisons

The Analog-to-Digital (A/D) Converter module in a micro-controller has five inputs for the 28-pin devices and eight for the 40/44-pin devices. The conversion of an analog input signal results in a corresponding 10-bit digital number. The A/D module has high and low-voltage reference input that is software and serial communication is used to transfer the digital data to avoid the bit-missing and bit-mixing drawbacks of parallel data transfer. The A/D converter has a unique feature of being able to operate while the device is in Sleep mode. To operate in Sleep, the A/D clock must be derived from the A/D's internal RC oscillator. The A/D module has four registers. These registers are:

- A/D Result High Register (ADRESH)
- A/D Result Low Register (ADRESL)
- A/D Control Register 0 (ADCON0)
- A/D Control Register 1 (ADCON1)

1. ADCON0 REGISTER

R/W-1	R/W-0	R/W-0	R/W-0	R/W-0	R/W-0	U-0	R/W-0	
ADCS1	ADCS0	CHS2	CHS1	CHS0	GO/DONE	-	ADON	
							bit 7	bit 0

2. ADCON1 REGISTER

R/W-0	R/W-0	U-1	U-0	R/W-0	R/W-1	R/W-0	R/W-1	
ADFM	ADCS2	-	-	PCFG3	PCFG2	PCFG1	PCFG0	
							bit 7	bit 0

The ADCON0 register controls the operation of the A/D module. The ADCON1 register configures the functions of the port pins. The port pins can be configured as analog inputs (RA3 can also be the voltage reference) or as digital I/O.

3. Selecting the A/D Conversion Clock

The A/D conversion time per bit is defined as TAD. The A/D conversion requires a minimum 12 TAD per 10-bit conversion. The source of the A/D conversion clock is software selected. The seven possible options for TAD are:

- 2 TOSC
- 4 TOSC
- 8 TOSC
- 16 TOSC
- 32 TOSC
- 64 TOSC
- Internal A/D module RC oscillator (2-6 μs)

For correct A/D conversions, the A/D conversion clock (TAD) must be selected to ensure a minimum TAD time of 1.6 μs.

VIII. SOFTWARE USED

To run any robot, we need a software and a unique coding which leads to give the successful control over robot according to their application. Here, we have used MPLAB for preparing coding under the plate-form of Embedded system and fetch the software to the micro-controller. then for running and control purpose, we use Hyper-Terminal which is default in Window XP of Microsoft.

A. Embedded Systems:

A general definition of embedded systems is embedded systems are computing systems with tightly coupled hardware and software integration, which are designed to perform a dedicated function. In some cases, embedded systems can function as standalone system. These are the peripherals to communicate Embedded Systems with outside world such as:

- Serial Communication Interfaces (SCI): RS-232, RS-422, RS-485 etc
- Synchronous Serial Communication Interface: I2C, SPI
- Universal Serial Bus (USB)
- Networks: Ethernet, Controller Area Network, LonWorks, etc
- Timers: Capture/Compare and Time Processing Units
- Discrete IO: aka General Purpose Input/Output (GPIO)
- Analog to Digital/Digital to Analog (ADC/DAC)

Embedded system is a dynamic plate-form and flexibility is its weapon. In recent years, it is an open field for research and development specially in autonomous area.

B. MPLab:

It is a well known software to program a micro-controller and in this proposed robot, coding is written using this software only. One can go for other software too according to their availability and proficiency of the code-writer.

*C. Hyper Terminal:*

It is a default Window XP plate-form. It can be opened as- Start-All prog-Accessories-Communication-Hyper Terminal. The data transfer which is common to the control unit and the is 9600 bits per second as a default. One can open this plate-form, connect the RS-232 to one of the communication port and setting all the setting as default, make a connection over control unit and host PC. Further, the PC will send the command and according to the program the robot will response.

## IX. WORKING

After connecting control unit by host PC and establishing wireless connection between control unit and robot unit, give dc supply to the robot and AC/DC supply to the control unit. By pressing the RESET button on the robot unit, the micro-controller will send a command window page to the host PC regarding how to control the robot (i.e. by using which button it will move forward, reverse, left, right and expand or contract its arm). Once the command window appears on the PC screen, it indicates that the robot is wirelessly connected to the host PC.

Now, we can send the robot to the distant or desired places according to our desire or need by following the video footages sent from the robo mini-cam. Whenever any sensing material is being found by the robot sensor (here, metal sensor, so it will sense metal), the robot will send command to the PC –“bomb found”. By using robo-arm we can pick the bomb by contracting or expanding the arm and place it to the save place without any human interface. A buzzer will also beep when the bomb is found. Thus, we can detect, find and dispose the bomb to the safer place.

## X. CONCLUSION AND FUTURE RESEARCH

Although this research is still a proto-type only and for the demonstration purpose only. It is successfully demonstrated and also has proven to allow a two-way communication between robot and its controller which will allow a non-expert to interact with and can control it.

We are currently extending this system to allow for real time control over the robot from a remote place. The speed of robotic arm is also supposed to control using PWM. At the end of the research, we will get a fully automated robot with simple control over it and can be used as a real time “BOMB DETECTION ROBOT”

## ACKNOWLEDGEMENTS

We would like to thank S.P.VIJAYARAGAVAN, Asst. Professor, BHARATH UNIVERSITY for his enormous supports regarding technical expertise and guidance to develop this product.

## REFERENCES

- [1] William H. Yeadon, Alan W. Yeadon. Handbook of small electric motors. McGraw-Hill Professional, 2001.
- [2] Michael Barr. "Embedded Systems Glossary". *Neutrino Technical Library*. Retrieved 2007-04-21.
- [3] "Robotics: About the Exhibition". The Tech Museum of Innovation. Retrieved 2008-09-15.
- [4] [en.wikipedia.org/wiki/Analog-to-digital\\_converter](http://en.wikipedia.org/wiki/Analog-to-digital_converter)
- [5] [www.zigbee.org/](http://www.zigbee.org/)
- [6] [www.wtpl.co.in/](http://www.wtpl.co.in/)
- [7] W.Leohard,"control of electri drives",3<sup>rd</sup> ed.,New York:springer 2001
- [8] T.Song, J.Park, s. June and J. Jeon,"The development of interface devices for human robot interaction",Control, Automation and Systems,2007