

DYNAMIC VOLTAGE RESTORER FOR VOLTAGE SAG MITIGATION

¹RAVIKUMAR D. PATEL²VIJESH N. PATEL³ CHINTANKUMAR A. PATEL.

Department Of Electrical Engineering, L D College Of Engineering, Gujarat Technological University, Ahmedabad-380015, Gujarat, India.

ravipatel1189@gmail.com

ABSTRACT:

Power quality phenomena or power quality disturbance can be defined as deviation of the voltage and current from its ideal waveform. Power quality is one of the major factor now. There many custom power devices are available to mitigation of power quality problem. The DVR (Dynamic Voltage Restorer) is one of the most efficient and effective solution of all custom power device. The DVR is connected in series with the distribution system. The basic function of the DVR is to inject a dynamically controlled voltage generated by the forced commutated converter in series to the bus voltage by means of a booster transformer. This report describes introduction about power quality its problems DVR principle, and various type of voltage compensation techniques simulation result to understand the performances of the system under fault condition and other condition. In order to mitigation of power quality problem the custom power device like DVR efficient effective lower cost smaller size and fast dynamic response to the disturbances. For this project MATLAB SIMULIK is used to understand the system and power quality problems.

KEY WORDS: *Dynamic Voltage Restorer, Voltage Sags, Swells, Interruption, Power Quality, VSC.*

1. INTRODUCTION

Faults at either the transmission or distribution level may cause voltage sag or swell in the entire system or a large part of it. Also, under heavy load conditions, a significant voltage drop may occur in the system. Voltage sags can occur at any instant of

time, with amplitudes ranging from 10 – 90% and a duration lasting for half a cycle to one minute There are many different methods to mitigate voltage sags and swells, but the use of a custom Power device is considered to be the most efficient method [9]. Like Flexible AC Transmission Systems (FACTS) for transmission systems, the term custom power pertains to the use of power electronics controllers in a distribution system, especially, to deal with various power quality problems. Each of Custom Power devices has its own benefits and limitations [4]. Dynamic Voltage Restorer (DVR) is one of the most effective type of these devices. There are numerous reasons why the DVR is preferred over the others. A few of these reasons are presented as follows. The SVC pre-dates the DVR, but the DVR is still preferred because the SVC has no ability to control active power flow. Another reason is that the DVR costs less compared to the UPS. Other reasons include that the DVR has a higher energy capacity and lower costs compared to the SMES device. Furthermore, the DVR is smaller in size and costs less compared to the DSTATCOM [6]. Based on these reasons, it is no surprise that the DVR is widely considered as an effective custom power device in mitigating voltage sags. This paper Introduced Dynamic Voltage Restorer (DVR) and its operating principle [1]. Then, analyses of the voltage correction methods were presented. At the end, simulation results using MATLAB were illustrated and discussed.

2. STRUCTURE OF THE DVR

The DVR basically consists of a power circuit and a control circuit. Control circuit is used to derive the parameters (magnitude, frequency, phase shift, etc...) of the control signal that has to be injected by the

DVR. Based on the control signal, the injected voltage is generated by the switches in the power circuit. Power circuit mainly comprising of five units. The series voltage controller is connected in series with the protected load.

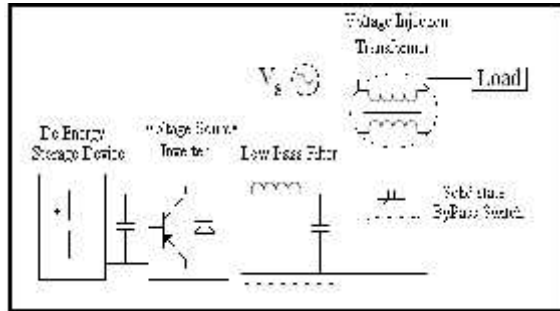

DVR Power circuit

A. *DC energy storage device*: This provides the realpower requirement of the DVR during compensation. [9]

B. *Voltage Source Inverter (VSI)*: VSI is basically used to convert the DC voltage supplied by the energy storage device to an AC voltage. This is coupled through injection transformer to the main system. Generally the rating of the VSI is low voltage and high current due to the use of step up injection transformers. [9]

C. *Passive Filter*: A Low pass filter consists of an inductor and a capacitor. It can be placed either at the high voltage side or the inverter side of the injection transformer. Basically it filters out the switching harmonic components from the injected voltage. [9]

D. *Bypass switch*: To protect the inverter from high currents, a by-pass switch (crowbar circuit) is incorporated to by-pass the inverter circuit. [9]

E. *Voltage Injection Transformer*: The high voltage side of the injection transformer is connected in series to the distribution line, while the low voltage side is connected to the DVR power circuit. The basic function of the injection transformer is to increase the voltage supplied by the filtered VSI output to the desired level while isolating the DVR circuit from the distribution network. The transformer winding ratio is predetermined according to the voltage required in the secondary side of the transformer. [9]

3. PROPERTIOUS CHOICE OF DVR

There are numerous reasons why DVR is preferred over other devices:

1. Although, SVC predominates the DVR but the latter is still preferred because the SVC has no ability to control active power flow.
2. DVR is less expensive compared to the UPS.
3. UPS also needs high level of maintenance because it has problem of battery leak and have to be replace as often as five years.
4. DVR has a relatively higher energy capacity and costs less compared to SMES device.
5. DVR is smaller in size and costs less compared to DSTATCOM
6. DVR is power efficient device compared to the UPS.

4. CONVENTIONAL CONTROL STRATEGIES

Several control techniques have been proposed for voltage sag compensation such as pre-sag method, in-phase method and minimal energy control [2] [3].

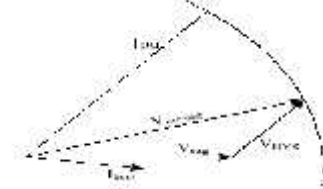

Pre-Sag Compensation Techniques

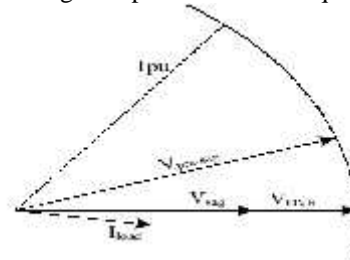

In-Phase Compensation Techniques

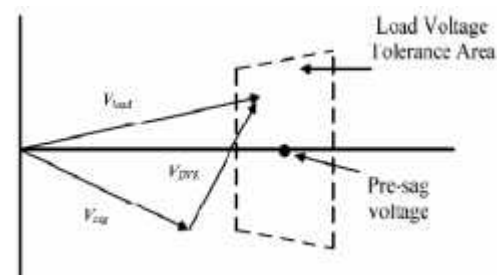

Voltage tolerance method with minimum energy injection

1. Pre-Sag Compensation Technique [11]:

The supply voltage is always tracked and the load voltage is compensated to the pre-sag condition. Before a sag occur, $V_S = V_L = V_O$. Here V_S is supply voltage, V_L is load voltage and V_O is pre sag voltage. The voltage sag results in drop in the magnitude of the supply voltage to V_S1 . The phase

angle of the supply also may shift. The DVR injects a voltage V_{C1} such that the load voltage ($V_L = V_{S1} + V_{C1}$) remains at V_o i.e. pre sag voltage (both in magnitude and phase).

2. In-Phase Compensation Technique [11]:

In this technique, only the voltage magnitude is compensated. V_{DVR} is in-phase with the left hand side voltage of DVR. This method minimizes the voltage injected by the DVR, unlike in the pre-sag compensation. Fig.2 shows phase diagram for the in-phase compensation technique [9].

$$V_{DVR} = V_{inj}$$

$$V_{inj} = V_{pre-sag} - V_{sag}$$

3. Voltage tolerance method with minimum energy injection [11]:

A small drop in voltage and small jump in phase angle can be tolerated by the load itself. If the voltage magnitude lies between 90%-110% of nominal voltage and 5%-10% of nominal state that will not disturb the operation characteristics of loads. Both magnitude and phase are the control parameter for this method which can be achieved by small energy injection.

5. OPERATING PRINCIPLE OF DVR

The basic function of the DVR is to inject a dynamically controlled voltage V_{DVR} generated by a forced commutated converter in series to the bus voltage by means of a booster transformer. The momentary amplitudes of the three injected phase voltages are controlled such as to eliminate any detrimental effects of a bus fault to the load voltage V_L . This means that any differential voltages caused by disturbances in the ac feeder will be compensated by an equivalent voltage generated by the converter and injected on the medium voltage level through the booster transformer [5]. The DVR works independently of the type of fault or any event that happens in the system, provided that the whole system remains connected to the supply grid, i.e. the line breaker does not trip. For most practical cases, a more economical design can be achieved by only compensating the positive and negative sequence components of the voltage disturbance seen at the input of the DVR (because for a typical distribution bus configuration, the zero sequence part of a disturbance will not pass through the step down transformer which has infinite impedance for this component). The DVR has two modes of operation which are: standby mode and boost mode. In standby mode ($V_{DVR}=0$), the booster transformer's low voltage winding is shorted through the converter. No

switching of semiconductors occurs in this mode of operation, because the individual converter legs are triggered such as to establish a short-circuit path for the transformer connection. Therefore, only the comparatively low conduction losses of the semiconductors in this current loop contribute to the losses. The DVR will be most of the time in this mode. In boost mode ($V_{DVR}>0$), the DVR is injecting a compensation voltage through the booster transformer due to a detection of a supply voltage disturbance [6].

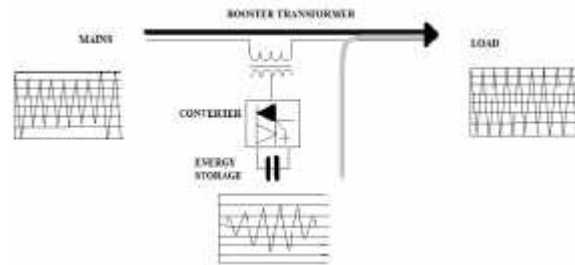

Principle of DVR system

6. TEST SYSTEM FOR DVR

Single line diagram of the test system shown in the figure.5 for DVR is composed by a 13 kV, 50 Hz generation system, feeding two transmission lines through a 3- winding transformer connected in Y/S/S, 13/115/115 kV. Such transmission lines feed two distribution networks through two transformers connected in S/Y, 115/11 kV.

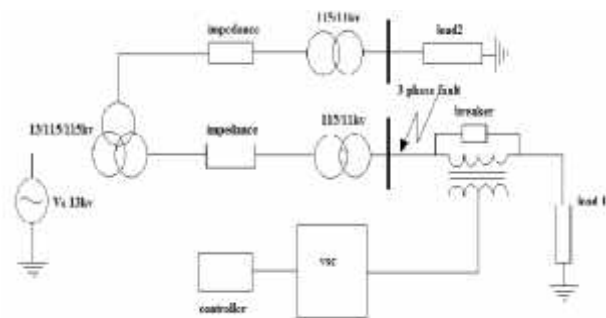

Single line diagram of the test system for DVR

7. SIMULATION RESULTS

The first simulation was done with no DVR and a three phase motor is applied to the system at point with. The second simulation is carried out at the same scenario as above but a DVR is now introduced at the load side to compensate the voltage sag occurred due to the three phase motor starting applied. When the

DVR is in operation the voltage interruption is compensated almost completely and the RMS voltage at the sensitive load point is maintained at normal condition.

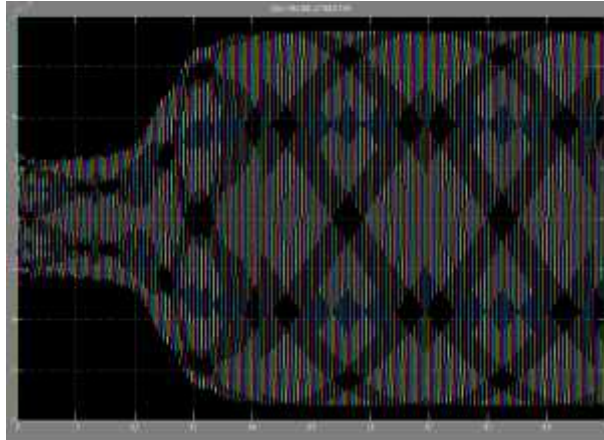

Load voltage without DVR

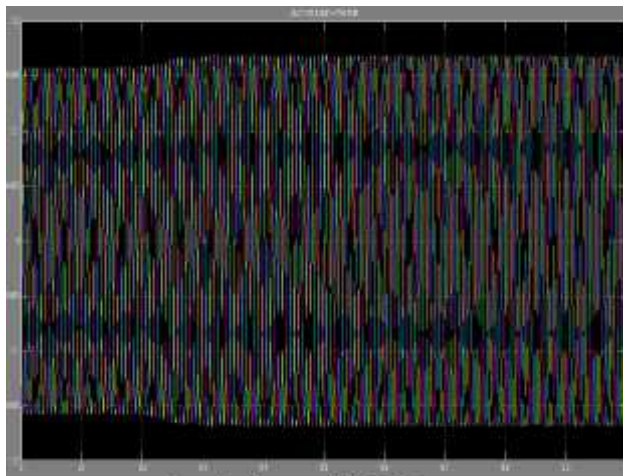

Load voltage with DVR

8. CONCLUSION

This paper has presented the power quality problems such as voltage dips, swells, distortions and harmonics. Compensation techniques of custom power electronic devices DVR was presented. The design and applications of DVR for voltage sags and comprehensive results were presented. A PWM-based control scheme was implemented. As opposed to fundamental frequency switching schemes already available in the MATLAB/ SIMULINK, this PWM control scheme only requires voltage measurements. This characteristic makes it ideally suitable for low-voltage custom power applications

The simulation results show clearly the performance of a DVR in mitigating voltage sags and swells. The DVR handles both balanced and unbalanced

situations without any difficulties and injects the appropriate voltage component to correct rapidly any anomaly in the supply voltage to keep the load voltage balanced and constant at the nominal value.

REFERENCES

1. Deepa S., Dr.Rajapandian S., "Voltage Sag Mitigation Using Dynamic Voltage Restorer System", International Journal of Computer and Electrical Engineering, Vol. 2, No. 5, October, 2010, pp.1793-8163
2. R. Omar and N. Abd Rahim, "MITIGATION OF VOLTAGE SAGS/SWELLS USING DYNAMIC VOLTAGE RESTORER (DVR)" ARPN Journal of Engineering and Applied Sciences, VOL. 4, NO. 4, JUNE 2009, pp.50-56
3. "IEEE Recommended Practice for Monitoring Electric Power Quality", IEEE std 1159-1995, 2009, pp. c1 – 81
4. N.G. Hingorani, Introducing Custom Power, in IEEE Spectrum, Vol.32, 1995, pp. 41-48
5. Wahab S. W. and Yusof A. M. "Voltage Sag and Mitigation Using Dynamic Voltage Restorer (DVR) System" ELEKTRIKA Journal of Engineering and Applied Sciences, Vol. 8, No. 2, 2006, pp. 32-37
6. Paul S., Saha P., Panda G., "Power Quality Improvement Using New Control Algorithm Based Dynamic Voltage Restorer" IJAREEIE, Vol.1, No.3, September 2012, pp.181-189
7. Pakharia A., Gupta M. "DYNAMIC VOLTAGE RESTORER FOR COMPENSATION OF VOLTAGE SAG AND SWELL: A LITERATURE REVIEW" International Journal of Advances in Engineering & Technology, July 2012. Vol. 4, Issue 1, pp. 347-355
8. Ramasamy, A.K.; Krishnan Iyer, R.; Ramachandaramuthy, V.K.; Mukerjee, R.N." Dynamic Voltage Restorer For Voltage Sag Compensation" International Conference On PEDS, Vol. 2, Year: 2005, pp. 1289 – 1294
9. Bhaskar M. A., Dash S. S., Subramani C., Kumar M. J., Kumar M. V., "Voltage Quality Improvement Using DVR," International Conference on Recent Trends in Information, Telecommunication and Computing, Vol.1, No.3, May 2010, pp.378-380
10. Tiwari H. P., Gupta S. K. "Dynamic Voltage Restorer against Voltage Sag" International Journal of Innovation, Management and

Technology, Vol. 1, No. 3, August 2010,pp.233-237

11. Tümay M., Teke A., Bayındır K. C., Cuma M.U. “SIMULATION AND MODELING OF A DYNAMIC VOLTAGE RESTORER” Modeling and Simulation IEEE 2004, pp.1-6
12. Kumar V., Prasad C., and Reddy S. “Power Quality Enhancement using Dynamic Voltage Restorer” Int. J. of Recent Trends in Engineering and Technology, Vol. 4, No. 3, Nov 2010,pp.139-140(REFERENCE)