

Implementation of Multi Level Converter Based DSTATCOM For Reactive Power Compensation and Harmonics Reduction

T.Poornima^{#1}, S.B.S.Viswanadh^{*2}

^{#1}(Department of Electrical & Electronics Engineering, VYCET, Chirala

Poornima.thota3@gmail.com

^{#2} (Department of Electronics & Communication Engineering, VYCET, Chirala

Viswanadh204@gmail.com

Abstract: Modern power systems are of complex networks, where hundreds of generating stations and thousands of load centres are interconnected through long power transmission and distribution networks. Even though the power generation is fairly reliable, the quality of power is not always so reliable. Power distribution system should provide with an uninterrupted flow of energy at smooth sinusoidal voltage at the contracted magnitude level and frequency to their customers. Power system especially distribution systems, have numerous nonlinear loads, which significantly affect the quality of power. Shunt compensation for medium voltage distribution systems requires higher rating for voltage source converters (VSCs). Ratings of the semiconductor devices in a VSC are always limited; therefore, for higher rated converters it is desirable to distribute the stress among the number of devices using multilevel topology. Cascaded multilevel configuration of the inverter has the advantage of its simplicity and modularity over the configurations of the diode-clamped and flying capacitor multilevel inverters. Application of cascaded multilevel converters for shunt compensation of distribution systems has been described in Literature. This paper presents an investigation of five-Level Cascaded H – bridge (CHB) Inverter as Distribution Static Compensator (DSTATCOM) in Power System (PS) for compensation of reactive power and harmonics. The advantages of CHB inverter are low harmonic distortion, reduced number of switches and suppression of switching losses. A CHB Inverter is considered for shunt compensation of a 11 kV distribution system. Finally a phase shifted PWM (PSPWM) technique is adopted to investigate the performance of CHB Inverter. The results are obtained through Matlab/Simulink software package. The proposed DSTATCOM is simulated for nonlinear loads.

Keywords:

Distribution Static Compensator (DSTATCOM), Power quality level shifted pulse width modulation

(LSPWM), phase shifted pulse width modulation (PSPWM), Proportional-integral (PI) control.

I. INTRODUCTION

Power quality disturbance, is generally defined as any change in power (voltage, current, or frequency) that

interferes with the normal operation of electrical equipment. The study of power quality, and ways to control it, is a concern for electric utilities, large industrial companies, businesses, and even home users. The study has intensified as equipment has become increasingly sensitive to even minute changes in the power supply voltage, current, and frequency. A growing power quality concern is harmonic distortion that is caused by the non-linearity of customer loads. Harmonics distorts the waveform shape of voltage, current level, which results in many disturbances.

Voltage sags are one of the power quality assets, which dragged the attention of many researchers as the sensitivity of loads are increasing due to the usage of power electronic devices. Fault at distribution level, sudden increase of loads, motor starting are some of the causes of the voltage sags. Such sudden variations of voltage are undesirable for sensitive loads. These undesirable voltage sags can be mitigated by connecting controlled devices either in series or shunt to the load. A few of such devices are dynamic voltage restorer (DVR) and DSTATCOM (distribution static compensator). Both these devices require voltage source converters for satisfactory operation. Usually the term power quality refers to maintaining a sinusoidal waveform of bus voltages at rated voltage and frequency. Electric power quality (EPQ) problems mainly include unbalance voltage and current, flicker, harmonics, voltage sag, dip, swell and power interruption. These power quality (PQ) problems may cause abnormal operations of devices. Hence, the maintenance and improvement of power quality has become an important scenario today.

Even though the power generation is fairly reliable, the quality of power is not always so reliable. Power distribution system should provide with an uninterrupted flow of energy at smooth sinusoidal voltage at the contracted magnitude level and frequency to their customers. Distribution systems, have numerous non linear loads, which significantly affect the quality of power. Apart from

non linear loads, events like capacitor switching, motor starting and unusual faults could also inflict power quality (PQ) problems. PQ problem is defined as any manifested problem in voltage /current or leading to frequency deviations that result in failure or mal operation of customer equipment.

Voltage sags and swells are among the many PQ problems the industrial processes have to face. Voltage sags are more severe. During the past few decades, power industries have proved that the adverse impacts on the PQ can be mitigated or avoided by conventional means, and that techniques using fast controlled force commutated power electronics (PE) are even more effective. PQ compensators can be categorized into two main types. One is shunt connected compensation device that effectively eliminates harmonics. The other is the series connected device, which has an edge over the shunt type for correcting the distorted system side voltages and voltage sags caused by power transmission system faults.

A multilevel inverter can reduce the device voltage and output harmonics by increasing the number of output voltage levels. There are several types of multilevel inverters which are named as cascaded multilevel inverter with separated dc sources, diode clamped multilevel inverter, flying capacitor multilevel inverter.

Diode-clamped multilevel inverter (DCMI):

The diode-clamped multilevel inverter uses capacitors in series to divide up the dc bus voltage into a set of voltage levels. To produce m levels of the phase voltage, a m -level diode-clamp inverter needs $m-1$ capacitors on the dc bus. single-phase five-level diode-clamped inverter is shown in the following Figure-1.

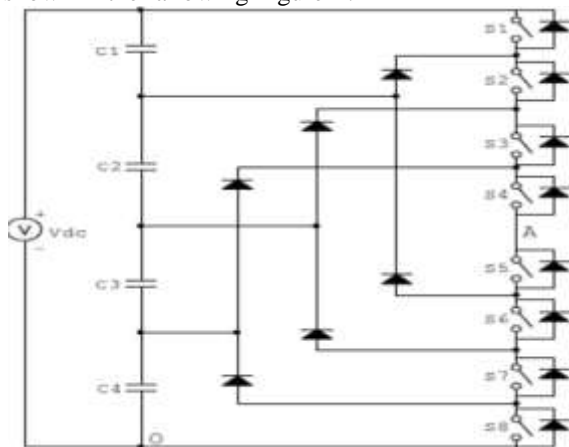

Figure:1 Flying-capacitor multilevel inverter (FCMI)

Probably the most important multilevel topology to appear recently is the flying capacitor inverter, or imbricate cells multilevel inverter, proposed by Meynard and Foch. A FCMI shown in the following Figure. It uses a ladder structure of dc side capacitors where the voltage on each capacitor differs from that of the next capacitor.

To generate m -level staircase output voltage, $m-1$ capacitors in the dc bus are needed. There are some significant disadvantages, those are the topology requires a lot of high voltage capacitors — many more than other topologies. These capacitors need to conduct the full load current for at least part of the switching cycle. Fortunately, if the switch frequency is high, these capacitors can usually be relatively small in capacitance value. Since these capacitors initially have zero voltage across them, starting the converter safely may be a non-trivial task.

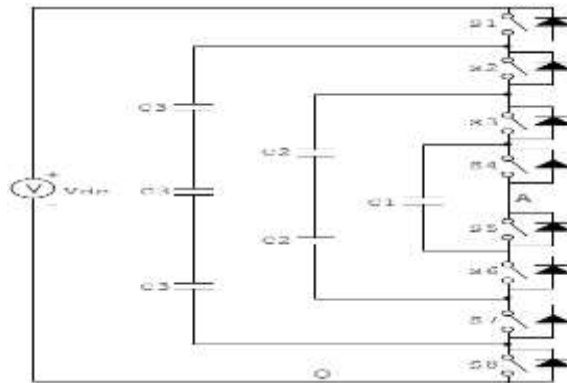

Figure:2 A single-phase five-level flying-capacitor inverter

Cascaded-inverters with separated dc sources:

The last structure introduced here is a multilevel inverter, which uses cascaded inverters with separate dc sources (SDCSs). The general function of this multilevel inverter is the same as that of the other two previous inverters. The multilevel inverter using cascaded-inverter with adjustable speed drive applications. The multilevel inverter using cascaded-inverter with SDCSs synthesizes a desired voltage from several independent sources of dc voltages, which may be obtained from batteries, fuel cells, or solar cells. This configuration recently becomes very popular in ac power supply and adjustable speed drive applications. This new inverter can avoid extra clamping diodes or voltage balancing capacitors.

This paper presents a DSTATCOM with a proportional integral controller based CHB multilevel inverter for the harmonics and reactive power mitigation of the nonlinear loads. This type of arrangements have been widely used for PQ applications due to increase in the number of voltage levels, low switching losses, low electromagnetic compatibility for hybrid filters and higher order harmonic elimination.

II. DESIGN OF MULTILEVEL BASED DSTATCOM

A. Principle of DSTATCOM

The STATCOM used in distribution systems is called DSTATCOM (Distribution-STACOM) and

its configuration is the same, but with small modifications. It can exchange both active and reactive power with the distribution system by varying the amplitude and phase angle of the converter voltage with respect to the line terminal voltage.

A D-STATCOM (Distribution Static Compensator), which is schematically depicted in Figure-3, consists of a two-level Voltage Source Converter (VSC), a dc energy storage device, a coupling transformer connected in shunt to the distribution network through a coupling transformer. The VSC converts the dc voltage across the storage device into a set of three-phase ac output voltages. These voltages are in phase and coupled with the ac system through the reactance of the coupling transformer. Suitable adjustment of the phase and magnitude of the D-STATCOM output voltages allows effective control of active and reactive power exchanges between the DSTATCOM and the ac system. Such configuration allows the device to absorb or generate controllable active and reactive power.

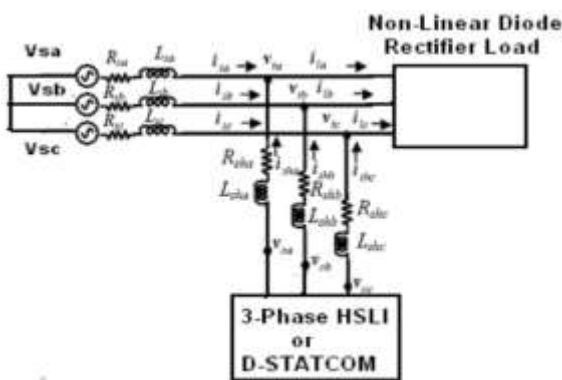

Figure - 3 Schematic Diagram of a DSTATCOM

The VSC connected in shunt with the ac system provides a multifunctional topology which can be used for up to three quite distinct purposes:

1. Voltage regulation and compensation of reactive power
2. Correction of power factor
3. Elimination of current harmonics.

B. Control for Reactive Power Compensation

Switches Turn ON	Voltage Level
S1,S2	Vdc
S3,S4	-Vdc
S4,S2	0

The aim of the control scheme is to maintain constant voltage magnitude at the point where the sensitive loads under system disturbances are connected. The control system only measures the rms voltage at the load point, i.e. no reactive power measurements are required. The VSC switching strategy is based on a sinusoidal PWM technique which offers simplicity and good response. Since custom power is a relatively low power application, PWM methods offer a more flexible option than the fundamental frequency switching methods which are favored in FACTS applications. Apart from this, high switching frequencies can be used to improve on the efficiency of the converter, without incurring significant switching losses.

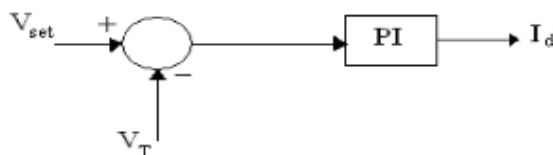

Figure - 4 PI control for reactive power compensation

The controller input is an error signal obtained from the reference voltage and the rms terminal voltage measured. Such errors processed by a PI controller; the output is the angle δ , which is provided to the PWM signal generator. It is important to note that in this case, of indirectly controlled converter, there is active and reactive power exchange with the network simultaneously. The PI controller processes the error signal and generates the required angle to drive the error to zero, i.e. the load rms voltage is brought back to the reference voltage.

C. Control for Harmonics Compensation

The Modified Synchronous Frame method is presented in [7]. It is called the instantaneous current component (id-iq) method. This is similar to the Synchronous Reference Frame theory (SRF) method. The transformation angle is now obtained with the voltages of the ac network. The major difference is that, due to voltage harmonics and imbalance, the speed of the reference frame is no longer constant. It varies instantaneously depending of the waveform of the 3-phase voltage system. In this method the compensating currents are obtained from the instantaneous active and reactive current components of the nonlinear load. In the same way, the mains voltages V(a,b,c) and the available currents $i_{l(a,b,c)}$ in $\alpha-\beta$ components must be Calculated as given by (4), where C is Clarke Transformation Matrix. However, the load current components are derived from a SRF based on the Park transformation, where „ θ “ represents the instantaneous voltage vector angle.

Table-1 Switching table of single CHB inverter

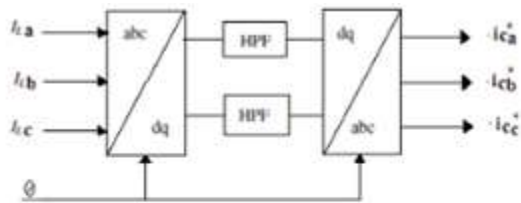

D. Cascaded H-Bridge Multilevel Inverter

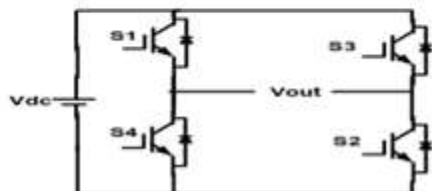

Fig:5 Circuit of single cascaded H Bridge Inverter

Fig.5 shows the circuit model of a single CHB inverter configuration. By using single H-Bridge we can get 3 voltage levels. The number of output voltage levels of CHB is given by $2n+1$ and voltage step of each level is given by $V_{dc}/2n$, where n is number of H-bridges connected incascaded. The switching table is given in Table 1.

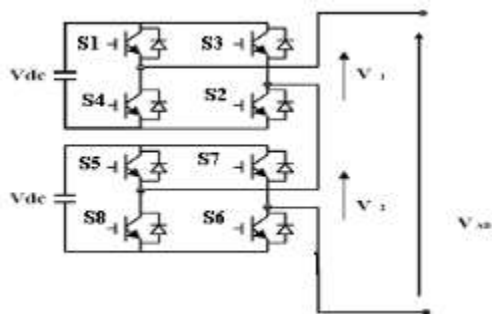

Figure-6 Block diagram of 5-level CHB inverter model

The switching mechanism for 5-level CHB inverter is shown in table-2.

Table 2. Switching table for 5-level CHB Inverter

Switches Turn On	Voltage Level
S1, S2	Vdc
S1,S2,S5,S6	2Vdc
S4,D2,S8,D6	0
S3,S4	-Vdc
S3,S4,S7,S8	-2Vdc

E. PWM Techniques for CHB Inverter

The most popular PWM techniques for CHB inverter are 1. Phase Shifted Carrier PWM (PSCPWM), 2. Level Shifted Carrier PWM (LSCPWM).

1. Phase Shifted Carrier PWM (PSCPWM)

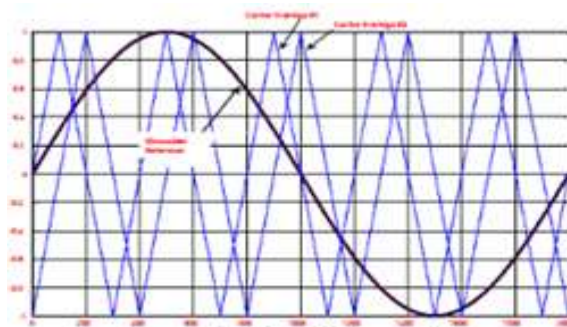

Fig:7 Phase shifted carrier PWM

Fig.6 shows the Phase shifted carrier pulse width modulation. Each cell is modulated independently using sinusoidal unipolar pulse width modulation and bipolar pulse width modulation respectively, providing an even power distribution among the cells. A carrier phase shift of $180^\circ/m$ (No. of levels) for cascaded inverter is introduced across the cells to generate the stepped multilevel output waveform with lower distortion.

IV MATLAB/SIMULINK MODELING AND SIMULATION RESULTS

Here Matlab/Simulink mode is developed for two cases. In case one Non linear loads without DSATCOM in case two Non linear loads with DSTATCOM are simulated.

A. Case one

Fig. 8 shows the Matlab/Simulink power circuit model without DSTATCOM and Fig.9 shows corresponding waveforms.

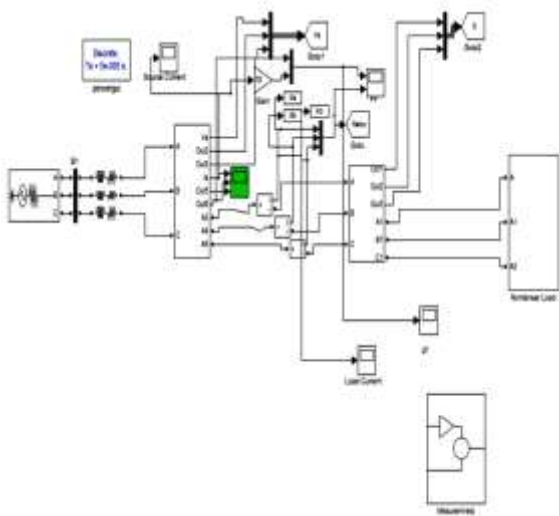

Fig.8 Matlab/Simulink power circuit model without DSTATCOM

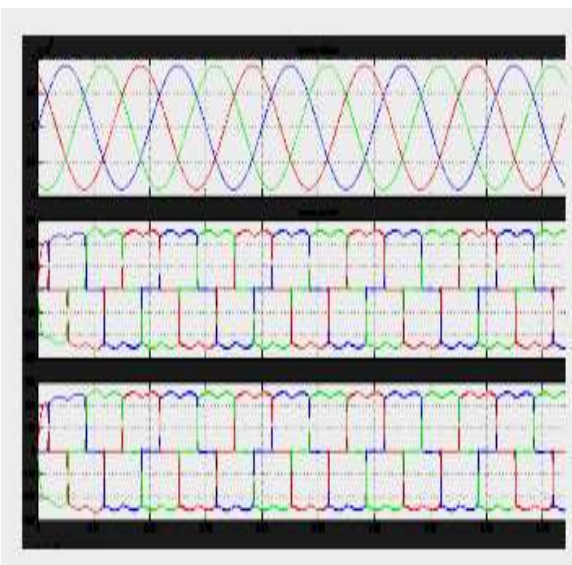

Fig. 9 Source voltage, current and load current without DSTATCOM

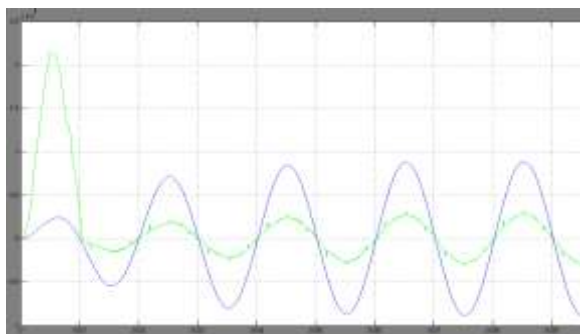

Fig. 10 Phase-A source voltage and current and pf

Fig. 10 shows the phase-A source voltage and current, even though the load is nonlinear RL load the source power factor is unity

B. Case two

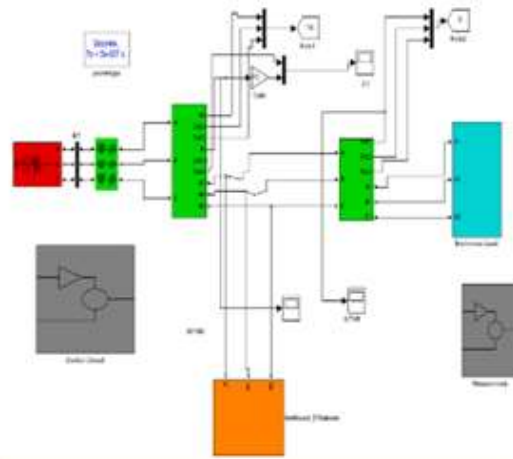

Fig. 11 Matlab/Simulink power circuit model with DSTATCOM

Fig. 12 shows the phase-A voltage of five level output of phase shifted carrier PWM inverter.

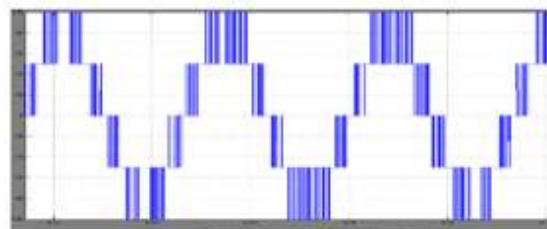

Fig. 12 five level PSCPWM output

Fig. 9 shows the three phase source voltages, three phase source currents and load currents respectively without DSTATCOM. It is clear that without STATCOM load current and source currents are same.

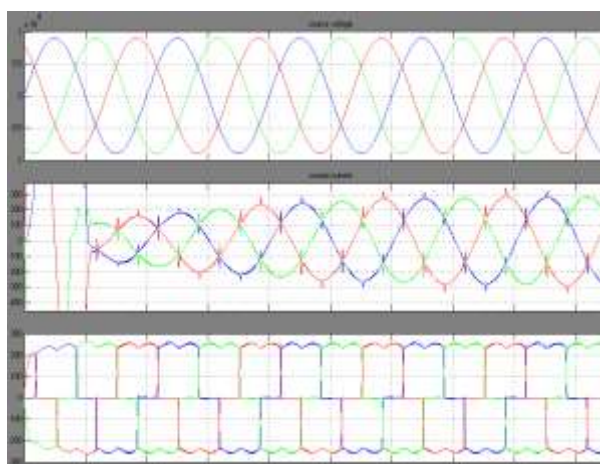

Fig. 13 Source voltage, current and load current with DSTATCOM

Fig. 13 shows the three phase source voltages, three phase source currents and load currents respectively with DSTATCOM. It is clear that with DSTATCOM even though load current is non sinusoidal source currents are sinusoidal

Fig. 14 shows the DC bus voltage. The DC bus voltage is regulated to 11kv by using PI regulator.



Fig. 14 DC bus voltage

Fig. 15 shows the phase-A source voltage and current, even though the load is non linear RL load the source power factor is unit.

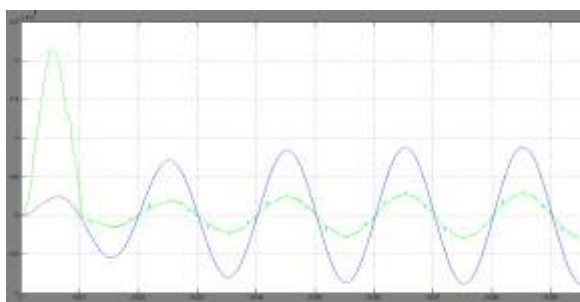

Fig. 15 Phase-A source voltage and current

Fig. 16 shows the harmonic spectrum of Phase -A Source current without DSTATCOM. The THD of source current without DSTATCOM is 36.89%.

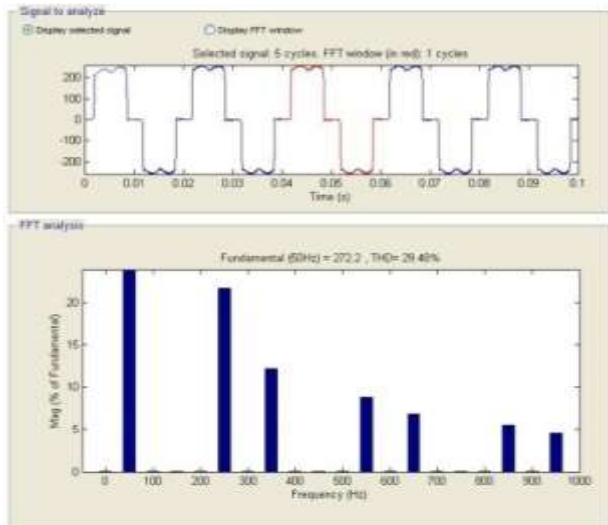

Fig. 16 Harmonic spectrum of Phase-A Source current without DSTATCOM

Fig. 17 shows the harmonic spectrum of Phase -A Source current with DSTATCOM. The THD of source current without DSTATCOM is 5.05%

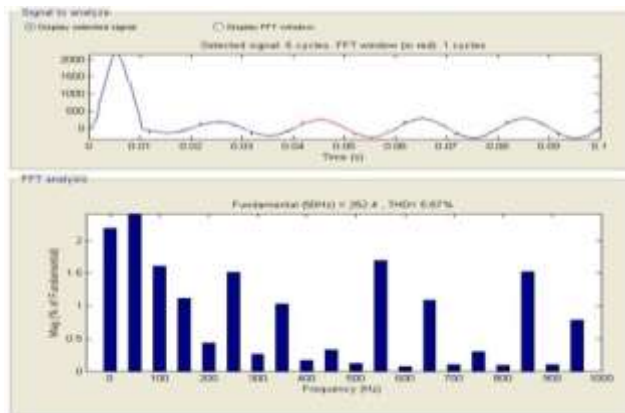

Fig. 17 Harmonic spectrum of Phase-A Source current with DSTATCOM

VI.CONCLUSION

Modern power systems are of complex networks, where hundreds of generating stations and thousands of load centres are interconnected through long power transmission and distribution networks. Even though the power generation is fairly reliable, the quality of power is not always so reliable. Power distribution system should provide with an uninterrupted flow of energy at smooth sinusoidal voltage at the contracted magnitude level and frequency to their customers. PS especially distribution systems, have numerous non linear loads, which significantly affect the quality of power. This paper studied a five level inverter used in a DSTATCOM in PS and has been successfully demonstrated in Matlab/Simulink. The benefits of five level inverter has low harmonics distortion, reduced number of switches to achieve the seven- level inverter output over the cascaded seven level inverter and reduced switching losses. Mathematical model for single H-Bridge inverter is developed which can be extended to multi H-Bridge. The source voltage , load voltage , source current, load current, power factor simulation results under non-linear loads are presented. Finally Matlab/Simulink based model is developed and simulation results are presented for both linear and non linear loads.

REFERENCES

- [1] K.A Corzine, and Y.L Familant, "A New Cascaded Multi-level H-Bridge Drive," IEEE Trans. Power.Electron., vol.17, no.1, pp.125-131. Jan 2002.
- [2] J.S.Lai, and F.Z.Peng "Multilevel converters - A new breed of converters," IEEE Trans. Ind.Appli., vol.32, no.3, pp.509-517. May/ Jun. 1996.
- [3] T.A.Maynard, M.Fadel and N.Aouda, "Modelling of multilevel converter," IEEE Trans. Ind.Electron., vol.44, pp.356-364. Jun.1997.
- [4] P.Bhagwat, and V.R.Stefanovic, "Generalized structure of a multilevel PWM Inverter," IEEE Trans. Ind. Appln, Vol.1A-

19, no.6, pp.1057-1069, Nov./Dec..1983.

[5] J.Rodriguez, Jih-sheng Lai, and F Zhengpeng, "Multilevel Inverters; A Survey of Topologies, Controls, and Applications," IEEE Trans. Ind. Electron., vol.49 , no4., pp.724-738. Aug.2002.

[6] RoozbehNaderi, and Abdolrezarahmati, "Phase-shifted carrier PWM technique for general cascaded inverters," IEEE Trans. Power.Electron., vol.23, no.3, pp.1257-1269. May.2008.

[7] Bhim Singh, Kamal AlHaddad&Ambrish Chandra, 1999, A Review of Active Filter for Power Quality Improvements, IEEE Trans on Industrial Electronics, 46(5), pp.960970

[8] Mauricio Angulo, Pablo Lezana, Samir Kouro, Jos'eRodr'iguezand Bin Wu,"Level-shifted PWM for Cascaded Multilevel Inverters with Even Power Distribution" IEEEPower Electronics specialist conference, 17-21 june 2007, pp.2373-2378.

[9] B. P. McGrath and D. G. Holmes, "Multicarrier PWM strategies for multilevel inverters," IEEE Trans. Ind. Electron., vol. 49, no. 4, pp. 858-867, August 2002.

AUTHORS PROFILE

T.Poornima has received the B.Tech degree in Electrical & Electronics Engineering from Jawaharlal Nehru Technological University in 2012. Presently She is pursuing M.Tech Power Electronics in VRS & YRN College of Engineering & Technology, Chirala. Her areas of interest are power electronics and power systems

S.B.S.Viswanadh has received the B.Tech degree in Electrical & Electronics Engineering from Jawaharlal Nehru Technological University in 2011 and M.Tech degree in Power Electronics. Presently he is working as an Asst.Prof in VYCET, Dept of Electrical & Electronics Engineering, Chirala. His areas of interest are power electronics and power systems

F
i
g
.

1
6

P
h
a
s
e
-
A

s
o
u
r
c
e

v
o
l
t
a