

A New Interleaved Three-Phase Single-Stage PFC AC–DC Converter

Nyalakonda Venkataramana Reddy

Ht no:14td1d0716

Clg:nigama engineering college,sambaiahpally karimnagar

Abstract: The widespread use of non-linear loads, such as variable speed drives (VSDs), power factor improvement has become more difficult. The presence of harmonic currents cause power capacitors to absorb them, as capacitor impedance is inversely proportional to frequency. The effects are overheating and increased dielectric stress of power capacitors, which result in their premature failure. These traditional approaches can also interact with harmonics, leading to harmonic amplifications at resonant frequency, which can damage the capacitors or components of the system. A new integrated three-level ac–dc converter is presented. The proposed converter integrates the operation of the boost power factor correction and the three-level dc–dc converter. The converter is made to operate with two independent controllers—an input controller that performs power factor correction and regulates the dc bus and an output controller that regulates the output voltage. The input controller prevents the dc-bus voltage from becoming excessive while still allowing a single-stage converter topology to be used. The paper explains the operation of the new converter in detail and discusses its features and a procedure for its proper design.

Keywords: AC–DC Power Conversion, Single-Stage Power Factor Correction (PFC).

I INTRODUCTION

Recently, developments in power electronics and semiconductor technology have lead improvements in power electronic systems. Pulse Width Modulation variable speed drives are increasingly applied in many new industrial applications that require superior performance. Hence, different circuit configurations namely inverters have become popular and considerable interest by researcher are given on them. Variable voltage and frequency supply to A.C drives is invariably obtained from a three-phase voltage source inverter. To overcome the limited semiconductor voltage and current ratings, some kind of series and/or parallel connection will be necessary. Due to their ability to synthesize waveforms with a better harmonic spectrum and attain higher voltages, multi-level inverters are receiving increasing attention in the past few years. THE ac–dc power supplies with transformer isolation are typically implemented with some sort of input power factor correction (PFC) to comply with harmonic standards such as IEC 1000-3-2 [1]. With the rapid rise in the use of electrical equipment in recent years, power converter manufactures are being pressed by regulatory to implement some form of PFC in their products. High power factor and low input current harmonics are more and more becoming mandatory

performance criteria for power converters. Although it is possible to satisfy by adding passive filter elements to the traditional passive diode rectifiers/LC filter input combination. The result of this converter is very bulky and heavy due to the size of the low frequency inductors and capacitors. Active power factor correction techniques have been used in AC-DC converter to improve power factor and reduce the harmonics. Active power factor correction can be classified into two stage scheme. Two stages PFC contain two independent power stages in cascade with PFC stage and DC-DC regulator. The total efficiency of the two stages is lower because the total power has to be processed twice with two cascade power stage. Cost of the circuit is increase several schemes have developed to combine stage into one stage [13]. This paper introduces the new converter is interfaced to induction machine drive to check the performance of the drive characteristics, explains its basic operating principles and its modes of operation, and discusses its features and its design.

II. CONVERTER OPERATION

The proposed converter and its key waveforms are shown in Figs. 1 and 2, respectively. The proposed converter uses auxiliary windings that are taken from the converter transformer to act as —magnetic switchesl to cancel the dc bus capacitor voltage so that the voltage that appears across the diode bridge output is zero. When the primary voltage of the main transformer is positive, auxiliary winding 1 ($N_{aux1}/N_1 = 2$) cancels out the dc bus voltage so that the output voltage of diode bridge 1 (DB1) is zero and the currents in input inductors L_{a1} , L_{b1} , and L_{c1} rise. When the primary voltage of the main transformer is negative, auxiliary winding 2 ($N_{aux2}/N_1 = 2$) cancels out the dc bus voltage so that the output voltage of diode bridge 2 (DB2) is zero and the currents in input inductors L_{a2} , L_{b2} , and L_{c2} rise. When there is no voltage across the main transformer primary winding, the total voltage across the dc bus capacitors appears at the output of the diode bridges and the input currents fall since this voltage is greater than the input voltage. If the input currents are discontinuous, the envelope of the input current will be sinusoidal and in phase with the input voltages. The converter modes of operation are explained in this section. The typical converter waveforms are shown in Fig. 2. The equivalent circuit in each stage is shown in Fig. 3. The converter goes through the following modes of operation.

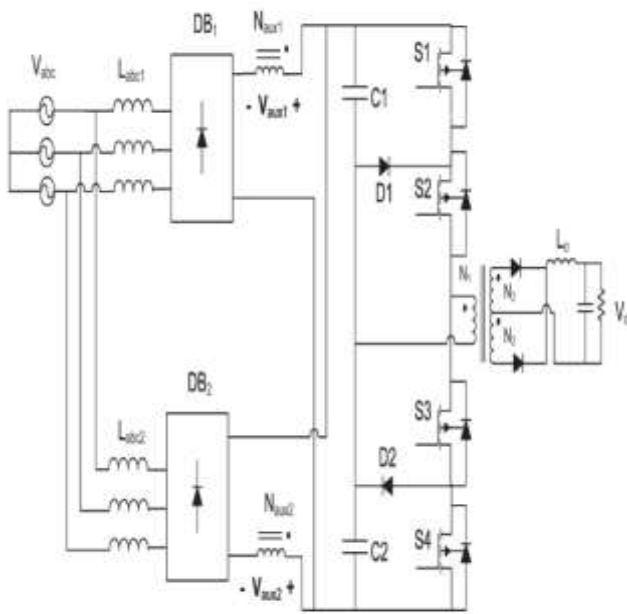
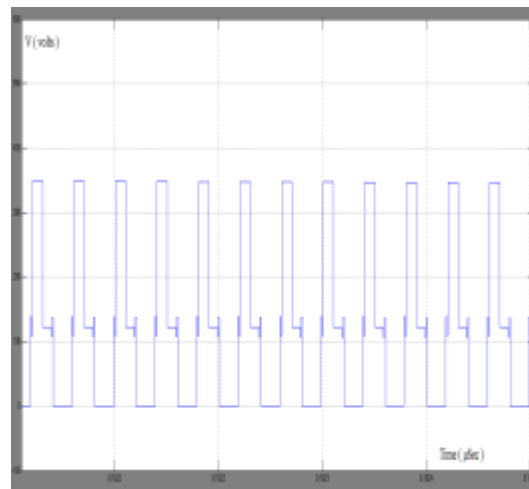
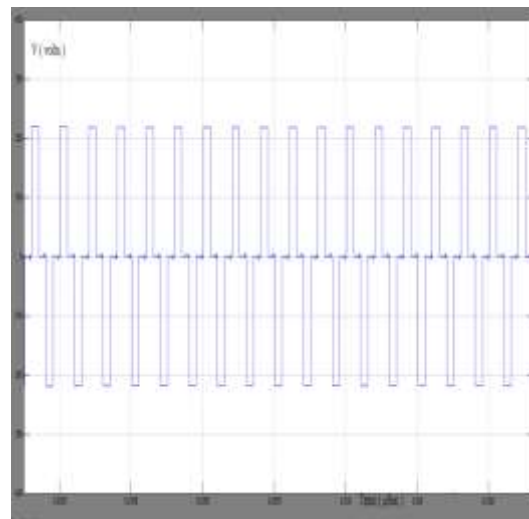
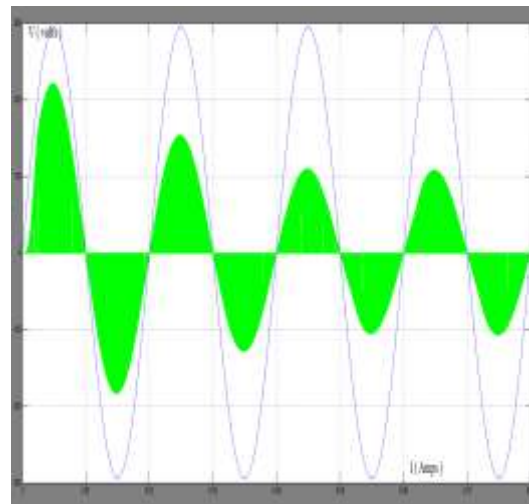

Fig.1. Proposed interleaved three-phase three-level converter.

III. CONVERTER ANALYSIS AND DESIGN

The analysis and the design of the proposed interleaved converter are almost identical to that presented and therefore are not presented here. Readers are referred to for details. In this paper, only differences in the analysis and the design are presented. With respect to analysis, steady-state operating points are identified using a computer program such as the one presented. The only difference between the analysis of the proposed converter and the one is the analysis and design of the input inductors. In the proposed interleaved converter, there are two sets of inductors (L_1 and L_2) at the input side, with each set conducting half the current. The analysis needs to consider the current in both these sets instead of just one. The values for L_1 and L_2 should be low enough to ensure that their currents are fully discontinuous under all operating conditions but not so low as to result in excessively high peak currents. The worst case to be considered is the case when the converter operates with minimum input voltage and maximum load since, if the input current in each set of inductors is discontinuous under these conditions, it will be discontinuous for all other operating conditions, and thus, an excellent power factor will be achieved.

IV. MATLAB/SIMULINK RESULTS



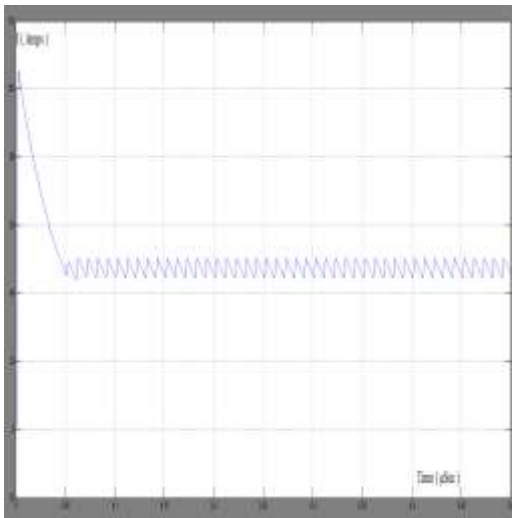
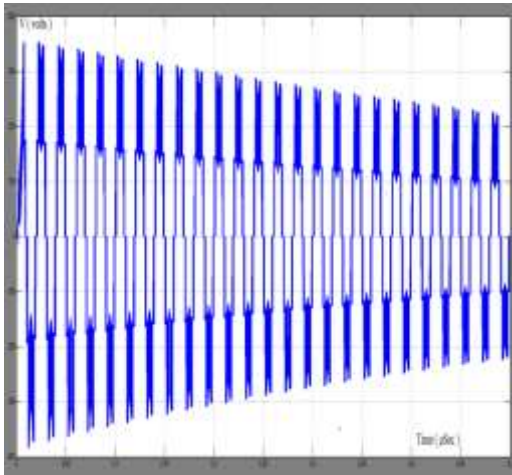

REFERENCES

- [1] *Limits for Harmonic Current Emission (Equipment Input Current >16 A per Phase)*, IEC1000-3-2 Int. Std., 1995.
- [2] *Limits for Harmonic Current Emission (Equipment Input Current >16 A per Phase)*, IEC1000-3-4 Int. Std., 1998.
- [3] *IEEE Recommended Practices and Requirements for Harmonic Control in Electric Power Systems*, IEEE Std. 519-1992, Apr. 1993.
- [4] B. Tamyurek and D. A. Torrey, —A three-phase unity power factor singlestage AC–DC converter based on an interleaved flyback topology,| *IEEE Trans. Power Electron.*, vol. 26, no. 1, pp. 308–318, Jan. 2011.
- [5] J. M. Kwon, W. Y. Choi, and B. H. Kwon, —Single-stage quasi-resonant flyback converter for a cost-effective PDP sustain power module,| *IEEE Trans. Ind. Electron.*, vol. 58, no. 6, pp. 2372–2377, Jun. 2011.
- [6] H. L. Cheng, Y. C. Hsieh, and C. S. Lin, —A novel single-stage high-powerfactor AC/DC converter featuring high circuit efficiency,| *IEEE Trans. Ind. Electron.*, vol. 58, no. 2, pp. 524–532, Feb. 2011.
- [7] S. K. Ki and D. D.-C. Lu, —Implementation of an efficient transformer-less single-stage single-switch AC/DC converter,| *IEEE Trans. Ind. Electron.*, vol. 57, no. 12, pp. 4095–4105, Dec. 2010.
- [8] H. Ma, Y. Ji, and Y. Xu, —Design and analysis of single-stage power factor correction converter with a feedback winding,| *IEEE Trans. Power Electron.*, vol. 25, no. 6, pp. 1460–1470, Jun. 2010.

V.CONCLUSION

In this paper, a new converter topology has been proposed which has superior features over conventional topologies in terms of the required power switches and isolated dc supplies, control requirements, cost, and reliability. This will add up to the efficiency of the converter as well as reducing the size and cost of the final prototype. A new multilevel single-stage ac–dc converter is proposed in the paper. This converter is operated with two controllers, one controller that performs input PFC and a second controller that regulates the output voltage. The outstanding feature of this converter is that it combines the performance of two-stage converters with the reduction of cost of single-stage converters. The paper introduces the proposed converter, explains its basic operating principles and modes of operation, and discusses its design with respect to different dc-bus voltages.