

Experimental Investigations and Production of Methyl Ester Using Mahua Oil and their Performance in CI Engine

Lohith A.G¹, Dr S.S.Prabhakara², Santhosh B³

¹Tech Consulting, Tech Mahindra, Bangalore.

²Professor, Dept. of Mechanical Engineering, Don Bosco Institute of Technology, Bangalore.

³Associate consultant, unique industrial solution, Bangalore

Abstract— This paper is mainly concerned with an experimental investigations carried out on performance of biodiesel obtained from Mahua oil and its blends with diesel from 15%, 25%, 35% & 45% by volume for running a diesel engine. The properties of these blends were found to be comparable to diesel and confirming to the American standards. Engine performance, (brake specific fuel consumption, brake thermal efficiency, total energy consumption & total fuel consumption) Exhaust Gas Temperature emissions & emissions (CO, HC, NOx & CO₂) were measured to evaluate and compute the behaviour of the diesel engine running on biodiesel at injection pressures 200 bar & CR 17.5:1. The increase in power output, brake thermal efficiency and reduction in brake specific fuel consumption were observed. Injection pressure and compression ratios were found to have significant effects on engine performance parameters. The power output decreased with increase in the concentration of Mahua methyl ester in diesel. The reductions in exhaust emissions and brake specific fuel consumption together with increase brake power, brake thermal efficiency made the blend of biodiesel in between MB15 to MB25 is found suitable alternative fuel for diesel and thus could help in controlling air pollution.

Keywords— Mahua methyl ester, biodiesel, Di-Magnesium phosphate, Transesterification, performance, emission characteristic.

I. INTRODUCTION

With crude oil reserves estimated to last for few decades, there has been an active search for alternate fuels. The depletion of crude oil would cause a major impact on the transportation sector. Of the various alternate fuels under consideration, biodiesel, derived from vegetable oils, is the most promising alternative fuel to diesel due to the following reasons.

- Biodiesel can be used in the existing engine without any modifications.
- Biodiesel is made entirely from vegetable sources; it does not contain any sulfur, aromatic hydrocarbons, metals or crude oil residues.
- Biodiesel is an oxygenated fuel.
- Emissions of carbon monoxide and soot tend to reduce.
- The use of biodiesel can extend the life of diesel engines because it is more lubricating than petroleum diesel fuel.
- Biodiesel is produced from renewable vegetable oils/animal fats and hence improves the fuel or energy security and economy independence.

A lot of research work has been carried out to use vegetable oil both in its neat form and modified form. Since India is net importer of vegetable oils, edible oils cannot be used for production of biodiesel. India has the potential to be a leading world producer of biodiesel, as biodiesel can be harvested and sourced from non-edible oils like *Jatropha*, *Curcus*, *Pongamia Pinnata*, *Neem*, *Mahua*, *Castor*, *Linseed*, etc. Some of these oils produced even now are not being properly utilized. Out of these plants, we are focusing on Mahua which can grow in arid and wastelands. Implementation of biodiesel in India will lead to many advantages like green cover to wasteland, support to agriculture and rural economy and reduction in dependence on imported crude oil and reduction in air pollution.

Currently Fatty acid methyl esters (FAME) is commonly produced by performing a transesterification reaction with homogeneous base catalysts such as KOH or NaOH dissolved in methanol under mild conditions but the produced FAME is required to be purified. Moreover, the total cost of this process is not sufficiently competitive as compared to the cost of petroleum-derived diesel fuels. In order to solve these problems, several types of FAME production processes have been studied: homogeneous acid catalysed process, supercritical process, enzymatic process and heterogeneous catalyst process. The transesterification catalysed by solid base is a bright technology for the noble process featuring the fast-reaction rate under mild reaction conditions. In this paper our interests were focused on Di magnesium Phosphate for the purpose of studying the noble process using the solid base catalyst from the view point of their economical advantages.

In the present investigation biodiesel is prepared from Mahua oil using di-magnesium phosphate as heterogeneous catalyst. The properties of KOME thus obtained are compared with ASTM biodiesel standards. The performance and emission characteristics were analysed on a four stroke single cylinder direct injection diesel engine



Mahua flower, seeds and Tree.

II. EXPERIMENTAL PROCEDURE

A. Preparation of Solid base catalyst

Dibasic magnesium phosphate trihydrate ($MgHPO_4 \cdot 3H_2O$) was taken in a hot china-dish and made in the form of paste with deionized water. The paste was dried in a hot air oven at $120^\circ C$ for 24 hrs for removing the moisture content present in the mixture. Dried magnesium phosphate trihydrate is taken out from the furnace and crushed into fine particles, this fine particles of magnesium phosphate trihydrate is taken in a silica crucible and placed in muffle furnace and heated to about 5 hours by maintaining the temperature of $600^\circ C$. Thus the calcinated Di-magnesium phosphate ($Mg_2P_2O_7$) catalyst is prepared for the transesterification reactions.



Photograph of catalyst preparation



Photograph of Muffle Furnace

B. Production of MOME by Transesterification

Transesterification also called alcoholysis is the displacement of alcohol from an ester by another alcohol in a process similar to hydrolysis, except that an alcohol is employed instead of water. Suitable alcohols include: methanol, ethanol, propanol, butanol, and amyl alcohol. Methanol and ethanol are utilized most frequently. This process is widely used to reduce the viscosity of triglycerides, thereby enhancing the physical properties of fuel and improve engine performance. Thus fatty acid methyl ester (also known as biodiesel) is obtained by transesterification. Figure 4 shows the flow chart for Mahua oil transesterification catalyzed by Di-magnesium

Phosphate. Measured quantity of esterified Mahua oil is taken in a 3 neck flask with reflux condenser, the oil is heated up to $70^\circ C$. When it reaches $70^\circ C$ required quantity of methanol and calcinated Di-Magnesium Phosphate catalyst are added. The reaction time is about 3hrs. Transesterified oil is transferred into separating funnel and allowed to settle for about 7-8 hrs then three layers was formed as shown in figure 5, upper layer was biodiesel, middle layer was of glycerin and the last layer was catalyst. The catalyst and glycerin are separated. As per the flow chart methanol present in the biodiesel layer is removed by heating the biodiesel above $65^\circ C$ and decalcification is done using complexing agent such as Ethylene Di-amine tetra-acetic acid (EDTA) in order to remove the impurities present if any. The advantage of heterogeneous method is that the recovered catalyst can be reused. The Yield after this process was found to be 80-82% of biodiesel (800-820ml).

Transesterification process parameters

- Methanol to oil molar ratio :9:1
- Amount of calcinated Di-Magnesium Phosphate catalyst : 2% (w/v)
- Reaction Temperature : $70^\circ C$
- Reaction Time : 3 hours

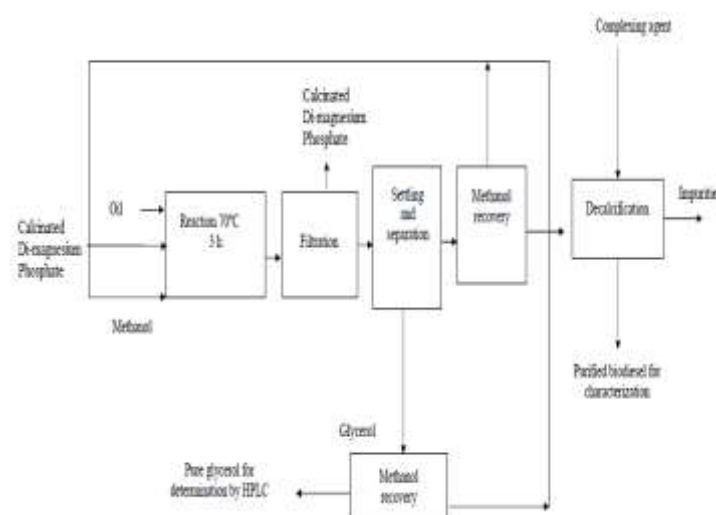

Flow chart for Mahua oil transesterification catalyzed by calcinated Magnesium phosphate.

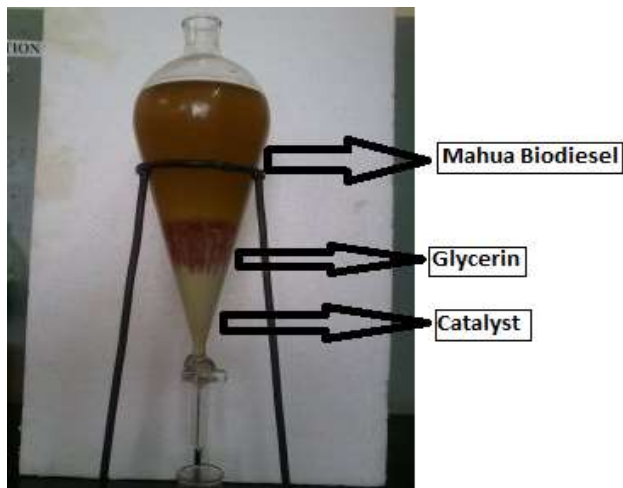

C. Properties of MOME and Diesel

American Society for Testing and Materials (ASTM) is an international standards organization that develops and publishes voluntary consensus technical standards for a wide range of materials, products, systems, and services. The obtained fuel properties are compared with ASTM standards and it is found that all the values are within specified range.

TABLE I

COMPARISON OF FUEL PROPERTIES WITH ASTM STANDARDS

PROPERTIES	UNITS	EXPERIMENTAL VALUES		
		BIODIESEL (MOME)	BIODIESEL STANDARDS (ASTM)	PETRO DIESEL
KINEMATIC VISCOSITY @40°C	CENTISTOKES	4.9	1.9-6.0	2.54
DENSITY	KG/M3	870	850-900	820
FLASH POINT	°C	141	>130	54
CALORIFIC VALUE	KJ/KG	37375	≥36000	43500
CLOUD POINT	°C	10	-3 TO 12	-28 TO -7
POUR POINT	°C	4	-15 TO 10	5.6 TO 11.1

D. Engine Test

Figure 6 shows the test rig setup. Mahua methyl ester blends (Biodiesel-MB15, MB25, MB35, MB45 and MB100) and pure Diesel were used to test a TAF-1 (Kirloskar, Four Stroke) single cylinder, water-cooled diesel engine having a rated output of 4.4 kW at 1500 rpm and a compression ratio of 17.5:1. The engine was coupled with an eddy current dynamometer to apply different engine loads (0,7,14,21,28

Nm). The emissions from the engine were studied at different engine loads. After the engine reach stabilized working condition, emissions like carbon monoxide (CO), Hydrocarbon (HC), Nitrous oxide (NO_x), carbon dioxide (CO₂) and exhaust gas temperature (EGT) were measured using a smoke-meter and an exhaust gas analyser.

Schematic Diagram of CI Engine Test Rig

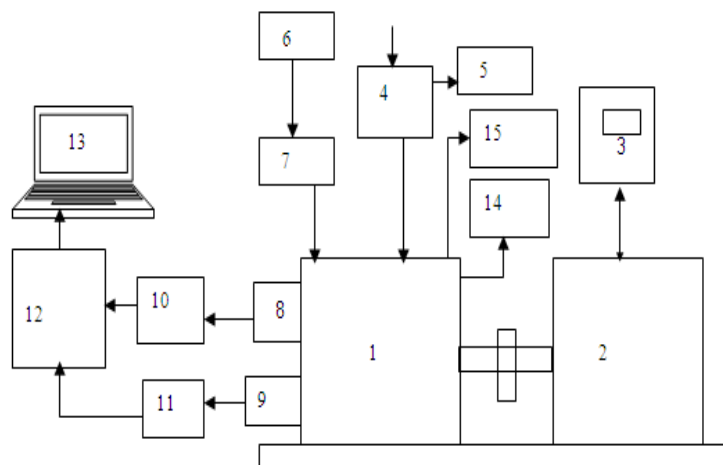

- 1. Diesel engine
- 2. Electrical Dynamometer
- 3. Dynamometer controls
- 4. Air box
- 5. U – tube manometer
- 6. Fuel tank
- 7. Fuel measurement flask
- 8. Pressure pickup
- 9. TDC position sensor
- 10. Charge amplifier
- 11. TDC amplifier circuit
- 12. A/D card
- 13. Personal computer
- 14. Exhaust gas analyzers
- 15. AVL smoke meter

III. RESULTS AND DISCUSSION

This paper compares brake specific fuel consumption, brake thermal efficiency, Exhaust gas temperature and exhaust emissions of MOME and its blends with those of diesel.

1. PERFORMANCE CHARACTERISTICS

Engine performance characteristics are the major criterion that governs the suitability of a fuel. This study is concerned with the evaluation of brake Thermal efficiency (BTE) and brake specific fuel consumption (BSFC) of the MOME diesel blends.

A. Brake Thermal Efficiency (BTE):

Brake thermal efficiency is defined as the ratio of energy in the brake power to the input fuel energy in appropriate units. [6, 7] Figure 7 shows that the variation of brake thermal efficiency (BTE) with load for different blends. In all the cases brake thermal efficiency is increased due reduced heat loss with increase in load. The maximum efficiency obtained in this experiment was 29.5% (MB45), 28.2% (MB25) for

200bar IP. But considering the viscosity, MB25 is the better option and this value is comparable with the maximum brake thermal efficiency for diesel (28.9% and 30.4% for 200bar). From the above graphs, it is found that brake thermal efficiency for biodiesel in comparison to diesel engine is a better option for part load on which most engine runs.

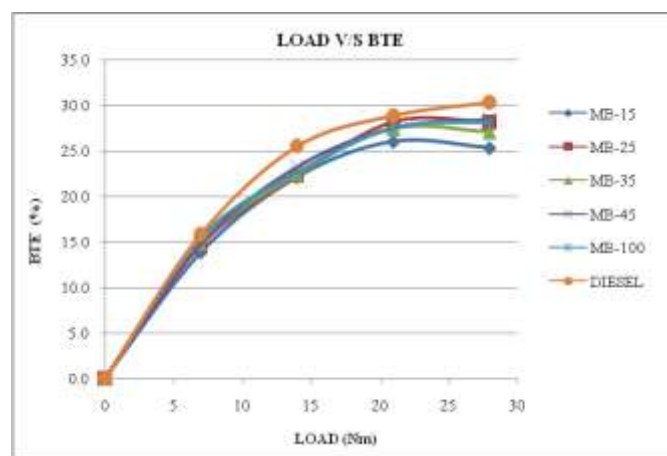

Brake thermal efficiency for IP of 200bar & 17.5:1CR vs. Load

B. Brake Specific Fuel Consumption (BSFC):

Specific fuel consumption is defined as the amount of fuel consumed for each unit of brake power developed per hour, Figure shows the variation of brake specific fuel consumption of Petro diesel and various blends of Mahua methyl ester at different loads for IP of 200bar. It is found that the specific fuel consumption for the blend MB25 is close to diesel. However if the concentration of Mahua oil in the blend is more than 25% the specific fuel consumption was found to be higher than diesel at all loads. This is because of the combined effects of lower heating value and the higher fuel flow rate due to high density of the blends. Higher proportions of Mahua oil in the blends increases the viscosity which in turn increased the specific fuel consumption due to poor atomization of the fuel.

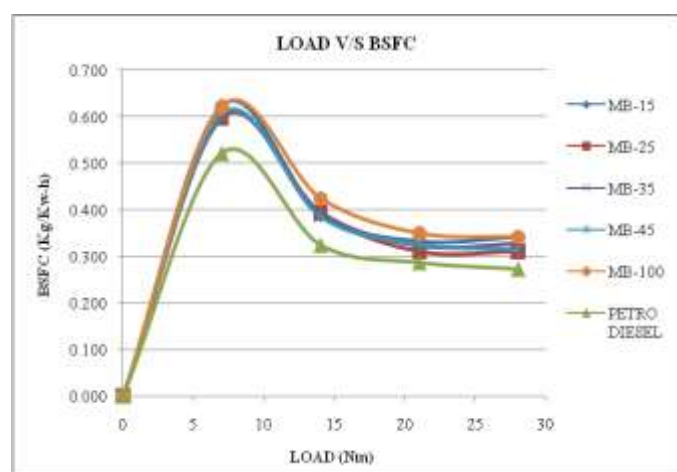

BSFC for IP of 200bar & 17.5:1CR vs. Load

C. Exhaust Gas Temperature (EGT) :

Figure shows the variation of exhaust gas temperature with load for various blends and Petro diesel. The results show that the exhaust gas temperature increases with increase in load for all blends. At all loads, Petro diesel was found to have the lowest temperature and the temperatures for various blends show an upward trend with increasing concentration of Mahua Biodiesel in the blends. The biodiesel contains oxygen which enables the combustion process and hence the exhaust gas temperatures are higher.

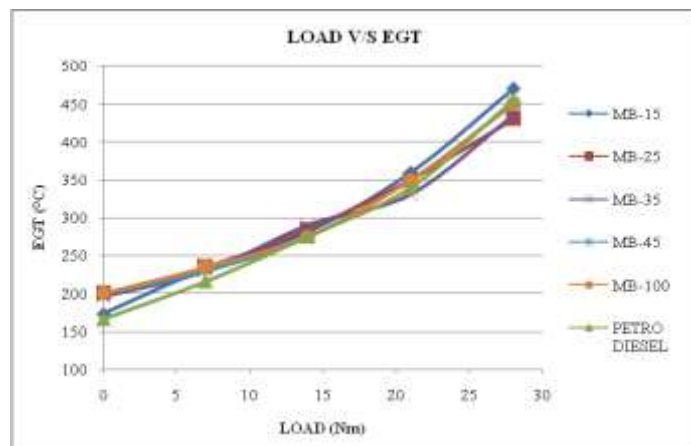

EGT for IP of 200bar & 17.5:1CR vs. Load

2. EMISSION CHARACTERISTICS

With problem like global warming ozone layer deletion and photochemical smog in addition to widespread air pollution automotive emission are placed under the microscope and every possible method is attempted to reduce emission. Hence this study compares the emission of pollutants nitrogen oxides, carbon monoxide, unburned hydrocarbon emissions and Carbon dioxide of Mahua methyl ester and its blend with diesel.

A. Carbon Monoxide Emission (CO):

Carbon Monoxide is measured by an exhaust analyser in percent (%) or parts per hundred. CO is a by product of combustion; therefore, if combustion does not take place, carbon monoxide will not be created. Based on this premise, when a misfire occurs, the carbon monoxide that would have normally been produced during the production process is not produced. Generally speaking, on fuel injected vehicles, high CO means too much fuel is being delivered to the engine for the amount of air entering the intake manifold.

Carbon monoxide emissions occur due to the incomplete combustion of fuel. The emissions of carbon monoxide are toxic. The analysis is as shown in Figure 10. Biodiesel blends give less carbon monoxide as compared to petro diesel due to complete combustion. When the percentage of blend of biodiesel increases, carbon monoxide decreases. This is due to more amount of oxygen content of biodiesels that result in

complete combustion of the fuel and supplies the necessary oxygen to convert CO to CO₂. At 28 Nm load, all blends & Petro diesel shows sudden increase in CO emissions.

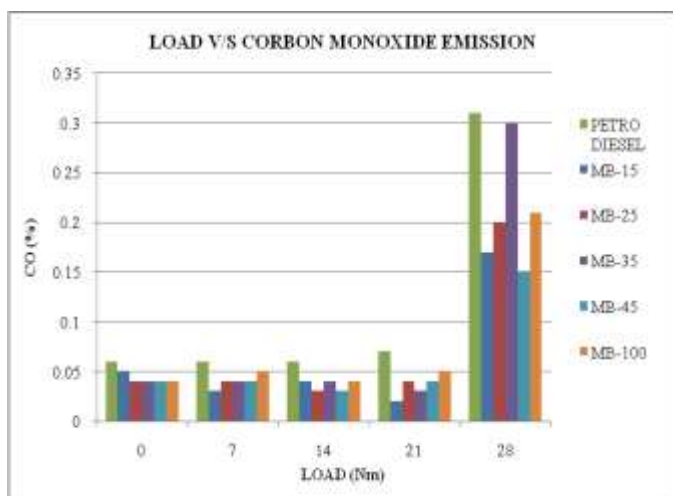

CO emission vs. Load for IP of 200bar & 17.5:1CR

B. Unburnt Hydro Carbon Emission (HC):

Hydrocarbons are measured by an exhaust analyser in parts per million (ppm). As we know, HC is unburnt fuel that remains as a result of a misfire. When combustion doesn't take place or when only part of the air/fuel charge burns, hydrocarbon levels goes up. Figure 11 shows the variation of HC emission with load for different fuels. It was observed that HC emission of the various blends was lower at partial load, but increased at higher engine load. This is due to the availability of less oxygen for the reaction when more fuel is injected into the engine cylinder at higher engine load. It is also observed from the graphs that biodiesel blends give relatively lower HC as compared to the diesel. This is because of better combustion of the biodiesel inside the combustion chamber due to the availability of excess content of oxygen in the biodiesel blends as compared to Petro diesel.

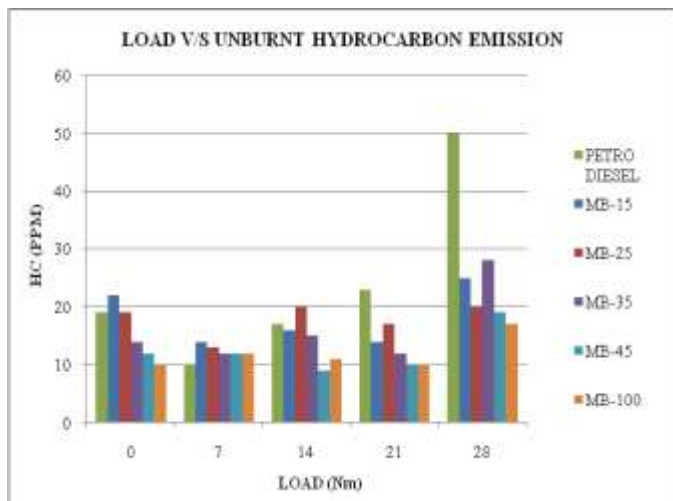

Unburnt HC emission vs. Load for IP of 200bar & 17.5:1CR

C. Nitrous Oxide Emission (NO_x):

Nitrous Oxides are measured by an exhaust analyser in parts per million (ppm). Anything which causes combustion temperatures to rise will also cause NO_x emissions to rise. Misfire can also cause NO_x to rise because of the increase in oxygen that it causes in the catalytic converter feed gas. NO_x is more likely to cause respiratory problems such as asthma, coughing, etc

NO_x emissions are extremely undesirable. Three conditions which favour NO_x formation are higher combustion temperature, more oxygen content and faster reaction rate. The above conditions are attained in biodiesel combustion very rapidly as compared to petro diesel. Hence, NO_x formations for biodiesel blends are always greater than diesel. It can be observed from figure12 that at higher power output conditions, due to higher peak temperatures, the NO_x values are likely higher for both biodiesel and Petro diesel fuel. NO_x emissions increase when fuelled with diesel- biodiesel fuel blends as compared to conventional diesel fuel. This is one of the major drawbacks of biodiesel as NO_x emission is hazardous to human health.

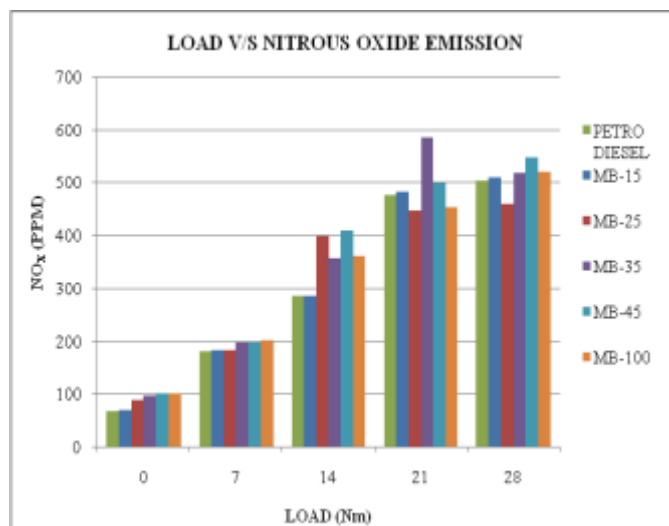

NO_x emission vs. Load for IP of 200bar & 17.5:1CR

D. Carbon Dioxide Emission (CO₂):

Carbon Dioxide is measured by an exhaust analyser in percent (%) or parts per hundred. Carbon dioxide is a by-product of efficient and complete combustion. Carbon dioxide levels are affected by air/fuel ratio, spark timing, and any other factors which effect combustion efficiency.

Figure shows the emission levels of CO₂ for various blends and petro diesel. Test measurements reveals that the CO₂ emission for all blends were less as compared to petro diesel at all loads. The rising trend of CO₂ emission with load is due to the higher fuel entry as the load increases. Bio-fuels contain lower carbon content as compared to petro diesel and hence the CO₂ emission is comparatively lower.

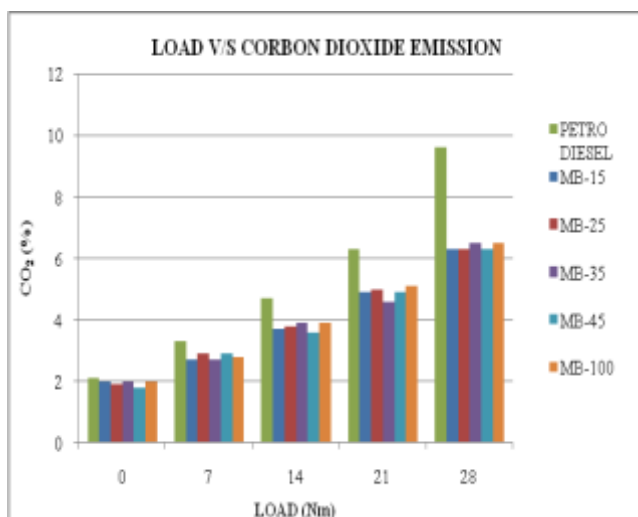

CO₂ emission vs. Load for IP of 200bar & 17.5:1CR

IV. CONCLUSION

- ✚ Under the optimum conditions, the conversion of Mahua oil reaches over 80-82 %.
- ✚ Produced MOME using calcinated Di-Magnesium phosphate catalyst, satisfies the important fuel properties as per ASTM specification of Biodiesel.
- ✚ The existing diesel engine performs satisfactorily on biodiesel fuel without any significant engine modifications.
- ✚ Engine performance with biodiesel does not differ greatly from that of petro diesel fuel. The MB25 shows good brake thermal efficiency in comparison with diesel. A little increase in fuel consumption is often encountered due to the lower calorific value of the biodiesel.
- ✚ Most of the major exhaust pollutants such as CO, CO₂ and HC are reduced with the use of neat biodiesel and the blend as compared to Petro diesel which is very much beneficiary. But NO_x emissions increase when fuelled with diesel- biodiesel fuel blends as compared to conventional diesel fuel. This is one of the major drawbacks of biodiesel as NO_x emission is hazardous to human health.
- ✚ Among the blends, MB25 showed the better performance and emission characteristics at various loading conditions.
- ✚ From all the above points it can be concluded that produced Mahua oil Methyl Ester (MOME) using heterogeneous base catalyst i.e. calcinated Di-Magnesium phosphate is safer and can certainly be considered as a potential alternative fuel.

REFERENCES

- [1] Ashish Jawalkar, Kalyan Mahantesh, M Jagadish, Madhusudhan Merawade, M C Navindgi: "Performance and Emission Characteristics of Mahua and Linseed Biodiesel Operated at Varying Injection Pressures on CI Engine" *International Journal of Modern Engineering Research (IJMER)*, Vol.2, Issue.3, pp-1142-1149, 2012
- [2] S.Hawash, G.El Diwani, E.Abdel Kader, "Optimization of Biodiesel Production from Jatropha Oil By Heterogeneous Base Catalysed Transesterification" *International Journal of Engineering Science and Technology (IJEST)*, Vol. 3, Issue.6, pp5242-5251, 2011
- [3] Edgar L., Liu Y, Lopez D.E., Kaewta S., Bruce DA and Gooduin J.G. "Synthesis of biodiesel via acid catalysis". *Journal of Engg Chemistry. Res.*44, pp5353 – 5363, 2005.
- [4] Akoh C.C., Chang S.W., Lec G.C. and Shaw J.F. "Enzymatic approach to biodiesel production", *Journal of Agric. Food Chem.* 55, 8995 – 9005, 2007
- [5] Lohith.N, Dr. R.Suresh, Yathish.K.V, "Experimental Investigation of Compressed Ignition Engine Using Karanja Oil Methyl Ester (KOME) as Alternative Fuel" *International Journal of Engineering Research and Applications*, Vol. 2, Issue4, pp.1172-1180, 2012.

Books:

- [6] John.B.Heywood, *Internal combustion engine fundamentals*. (The McGraw Hill Book Co; 1988)
 - [7] V.Ganesan, *Internal combustion engines*. (The McGraw-Hill Pvt Ltd, 2011)
- Standards/ Patents:**
- [8] ASTM Standards for Biodiesel (B100).