

A Unique fusion of Audio filter for Hearing problems

1Siddhartha, 2Prof Amit Mishra
1M. tech. student, 2HOD
VITS, Jabalpur

Abstract: Audio enhancement became important when noise in signals causes loss of actual information. Many filters have been developed and still improving. A highly optimized core discrete Remez part of the Parks-McClellan (PM) filter along with wavelet type discrete symlet filter been proposed in the paper. The proposed algorithm DWT-REA is experimented for two speech signals and efficiency is checked with calculation of MSE. Performance is also evaluated for different value of noise level. Proposed Algorithm is also compared with simple REA for seeing the improvement in recovered signal. Proposed algorithm can easily applicable in the field of speech enhancement.

Keywords: Remez Exchange Algorithm, Finite Impulse Response (FIR), Parks-McClellan (PM), DWT, Symlet Wavelet, Audio enhancement.

I-Introduction

There are many applications where audio enhancement requires for example FM broadcasting or multimedia communication the quality of audio signal at the receiving end is never as was transmitted because of Noise or distortion or fading.

In order to enhance the audio quality of artificial reverberators, fast convolution techniques and hybrid reverberator structures have been explored by Andrea Primavera[1], Minje Kim propose the Probabilistic Latent Components Sharing (PLCS) is based on the probabilistic counterparts of Nonnegative Matrix Factorization model for collaborative audio enhancement, where common audio sources are constructed out of multiple noisy recordings of the same audio scene[4] Robert c. maher audio enhancement using nonlinear time-frequency filtering, they discussed that nonlinear and time-varying filters operate on the spectral representation in order to retain features that are attributable to the desired signal, such as human speech, while removing the features that are more likely to be due to the noise contamination[5].

The Remez exchange algorithm[6] is an optimization algorithm for audio enhancement that is commonly used in the design of FIR filters. It is popular because of its flexibility and computational efficiency. Also known as the Parks-McClellan algorithm[9], it works

by converting the filter design problem into a problem of polynomial approximation. The optimal Chebyshev FIR filter can often be found effectively using the Remez multiple exchange algorithms (typically called the ParksMcClellan algorithm when applied to FIR filter design). The Parks-McClellan/Remez algorithm also appears to be the most efficient known method for designing optimal Chebyshev FIR filters. The discrete wavelet transform (DWT)[12] is a linear transformation that operates on a data vector whose length is an integer power of two, transforming it into a numerically different vector of the same length.

Wavelets have an important application in signal denoising. After wavelet decomposition, the high frequency subbands[12] contain most of the noise information and little signal information. properties of Discrete wavelet transforms were employed to recover a signal from the signal with noise. The process of filtering can be broken into further steps which are: Analysis, Applying wavelet transform, Analysis Step.

Selecting an appropriate wavelet was a very important task in this step. The wavelet chosen should be similar to the signal that has to be filtered to give the best possible results, applying wavlets to filter out the signal, Parks-McClellan or remez exchange based filtering approach gives a filtered signal with small amount of noise present that small amount can be negligible in some application but there are application like secure data communication, multiplexed broadcasting, real time digital data communication where noise cannot be ignored. So a filter which can remove maximum noise and have high SNR, low BER and low MSE is need of the communication world. Thus, Remez exchange based filtering adding with wavelet filter approach gives us a quite efficient denoised audio signal.

II-Proposed Algorithm DWT-REA

The REA Algorithm is implemented using the following steps:

Initialization: Choose an extremal set of frequencies $\{\omega_i^{(0)}\}$.

Finite Set Approximation: Calculate the best Chebyshev approximation on the present extremal set, giving a value $\delta^{(m)}$ for the min-max error on the present extremal set.

$$P^m(\omega) \approx \sum_{k=0}^{m-1} c_k T_k(\omega) - \frac{1}{2} c_0 \dots \dots (1)$$

Where c_k is the chebyshev coefficient and T_k is the chebyshev polynomial

Interpolation: Calculate the error function $E(\omega)$ over the entire set of frequencies Ω .

$$|P^m(\omega) - f^m(\omega)| = E^m(\omega) \dots \dots \dots (1)$$

$P(\omega)$ is the approximating polynomial, $f(\omega)$ is the actual function.

Look for local maxima of $|E^{(m)}(\omega)|$ on the set Ω .

If $\max_{\omega \in \Omega} |E^{(m)}(\omega)| > \delta^{(m)}$, then update the extremal set to $\{\omega_i^{(m+1)}\}$ by picking new frequencies where $|E^{(m)}(\omega)|$ has its local maxima. Make sure that the error alternates on the ordered set of frequencies.

Return to Step 2 and iterate.

If $\max_{\omega \in \Omega} |E^{(m)}(\omega)| \leq \delta^{(m)}$, then the algorithm is complete. Use the set $\{\omega_i^{(0)}\}$ and the interpolation formula to compute an inverse discrete Wavelet transform to obtain the filter coefficients.

Figure 1 presents the modules in proposed work Next is DWT-REA section it is proposed work here first wavelet filtering module filter the noisy signal with wavelet which is type 6 symlet (sym6) which performs an interval dependent denoising of the noisy signal, using a wavelet decomposition at the level '5' with a wavelet which name is 'sym6' and perform soft thresholding. The family function of wavlet can define as

$$\varphi_{a,b}(t) = \frac{1}{\sqrt{a}} \varphi\left(\frac{t-b}{a}\right) \dots \dots \dots (2)$$

If $\varphi_{a,b}(a > 0, b \in IR)$,

For symlet type 6 the filter coefficient computed from the equation 2 are:-

- 0.00551593375469, 0.00124996104639,
- 0.03162528132994, -0.01489187564922, -
- 0.05136248493090, 0.23895218566605,
- 0.55694639196396, 0.34722898647835, -
- 0.03416156079324, -0.08343160770584
- 0.00246830618592 0.01089235016328

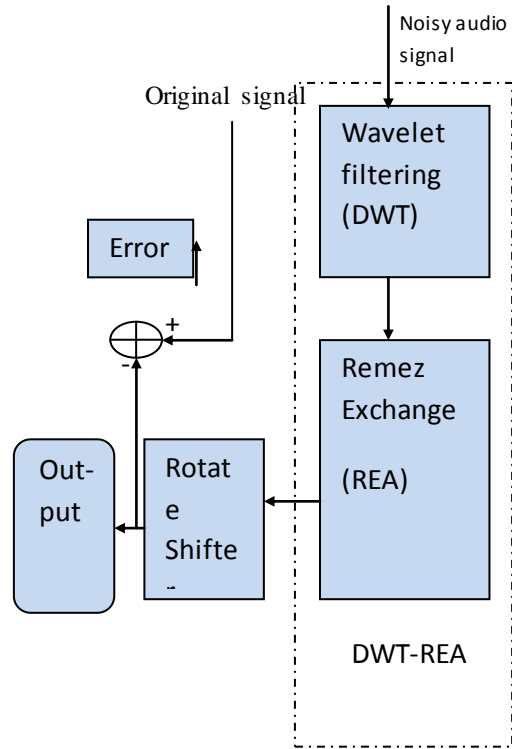

Figure 1 Proposed Block

Next type 6 REA is a Parks-McClellan optimal equiripple FIR filter design, FIR filter which has the best approximation to the desired frequency response described by F and A in the minimax sense. F is a vector of frequency band edges in pairs, in ascending order between 0 and 1. 1 corresponds to the Nyquist frequency or half the sampling frequency. At least one frequency band must have a non-zero width. A is a real vector the same size as F which specifies the desired amplitude of the frequency response. In present work because denoising is our aim F is chosen [0 0.14 0.15 0.16 0.17 1] and A is [1 1 1 1 1] the value of F can be vary as per the input signal. The order of FIR filter is '40', As the order 40 in FIR-PM filter gives delay of 40/2 samples hence it is requires to have 20 sample advance the output signal. Mean square error can be calculated as-

$$MSE = \frac{\sum_{c=0}^C \sum_{r=0}^R (X_{rc} - Y_{rc})^2}{R * C} \dots \dots \dots (3)$$

Here R in the number of Row and C is the number column. x is the input noisy signal and y is the output filtered signal.

III-Experimental Results

The results is been observed for two different input signal file Fig.1: the proposed Design Algorithm with different AWGN noise value in 'db'. Different Noise needed for testing all type of possible real life situations.

Proposed design DWT-REA the order of FIR is 40, type 6 of REA and symlet order 6 with 5 level decomposition wavelet filter is been selected.

Case study-1: for chirp signal figure 2 shown below shows actual input chirp signal and its 30db awgn noisy signal

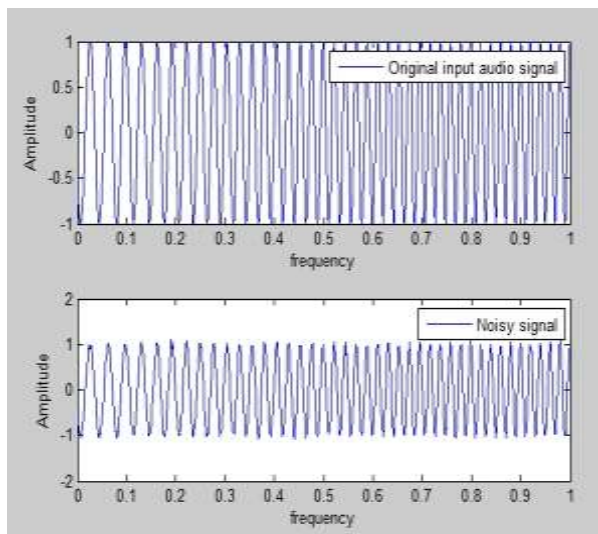

Figure 2: the original and chirp signal

Figure 3 shown below shows analytical comparison of given input chirp signal and enhanced filtered output signal.

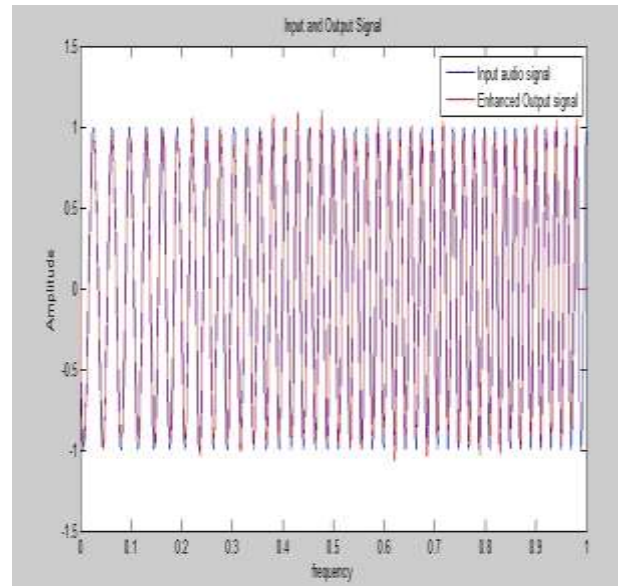

Figure 3: Original chirp shown by blue filtered enhanced output chirp signal by red

Figure 4 shown below shows a comparative analytical plot which is been develop for different noise quantity in input and output observed, the comparison is been done as mean square Error between chirp input and chirp output.

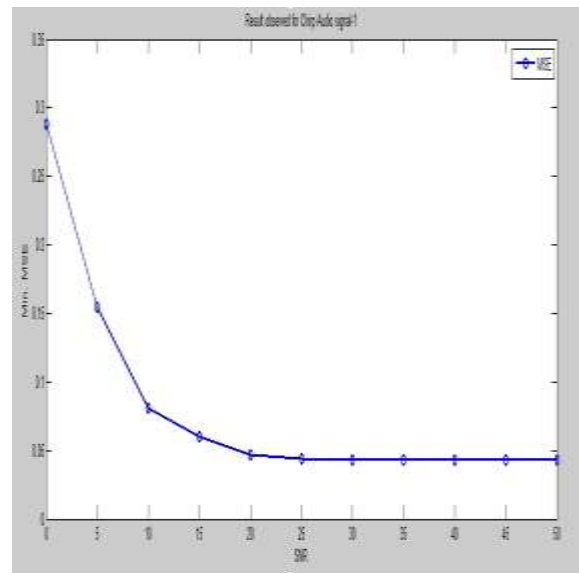

Figure 4: MSE for different noise value in Chirp signal

Table 1: MSE observed in chirp for different Noise level

S.No.	SNR	Min.MSE
1	0	0.2879
2	5	0.1546
3	10	0.0813
4	15	0.0597
5	20	0.047
6	25	0.0441
7	30	0.0427
8	35	0.0429
9	40	0.0431
10	45	0.0432
11	50	0.0433

The MSE for chirp signal in worst case obtain is 0.0105.

Case study-2: for audio signal-2 figure 5 shown below shows actual input audio signal and its 30db awgn noisy signal.

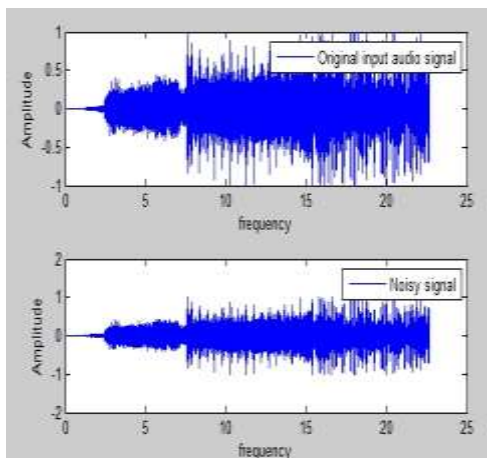

Figure 5: the Audio & noisy signal

Figure 6 shown below shows analytical comparison of given input audio signal and enhanced filtered output signal.

Figure 7 shown below shows analytical comparison of given input audio signal and enhanced filtered output signal.

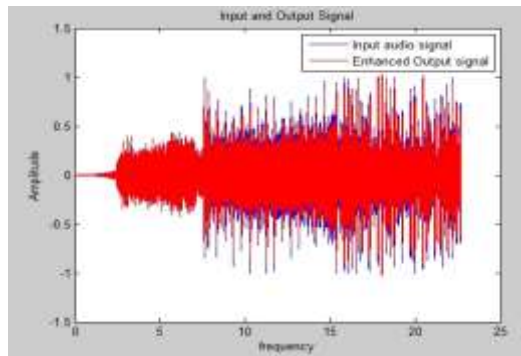

Figure 6: the blue is audio input signal and red filtered enhanced output

Table 2: MSE observed in Audio for different Noise level

S. No.	SNR(dB)	Min. MSE
1	0	0.0105
2	5	0.0078
3	10	0.0055
4	15	0.0038
5	20	0.0029
6	25	0.0024
7	30	0.0022
8	35	0.0021
9	40	0.0021
10	45	0.0021
11	50	0.0021

The MSE for Audio signal in worst case obtain is 0.2879.

Figure 8 shown below shows a comparative analytical plot which is been develop for different noise quality in input and output MSE observed, the comparision is been done as MSE between audio input and audio output

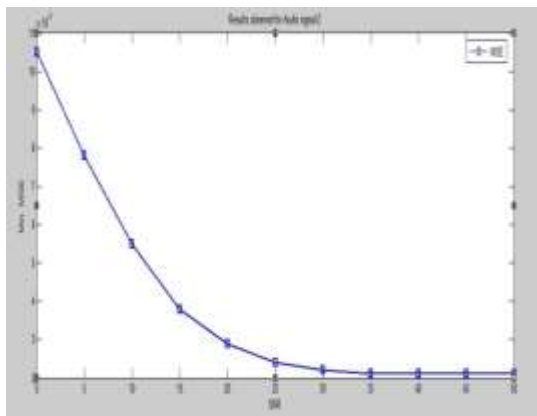

Figure 8: MSE for different noise value in Audio signal

Comparison of DWT-REA with REA: the comparison is been done as MSE between REA and proposed DWT-REA algorithm as shown in table 3 for an audio signal.

Table 3: MSE observed in DWT-REA and REA

S. No.	Algorithm	SNR(dB)	Min. MSE
1	REA	35	0.0442
2	DWT-REA	35	0.0021

V- Conclusion

DWT-REA Algorithm is successfully implemented and experimented for audio signals. Performance of the model shows quite good denoising of the recovered signal. Remez exchange algorithm with symlet wavelet function gives quite efficient minimum MSE which is compared with algorithm REA without DWT and justified better for different noise level. This proposed algorithm can be applied anywhere in the field of audio enhancement.

References

- [1] Andrea Primavera, "Advanced Algorithms for Audio Quality Improvement in Musical Keyboards Instruments", Doctoral School on Engineering Sciences, Università Politecnica delle Marche, pp 1-9, 11-feb-2013.
- [2] Antony W. Rix, John G. Beerends, Doh-Suk Kim, "Objective Assessment of Speech and Audio Quality—Technology and Applications", *IEEE Transactions on Audio, Speech, and Language Processing*, vol. 14, no. 6, pp 1890-1901 november 2006
- [3] J. robert stuart, "Coding High Quality Digital Audio", presented during campaign, Meridian Audio Ltd, Stonehill, Stukeley Meadows, Huntingdon, PE18 6ED, United Kingdom
- [4] Minje kim, Paris smaragdis, "collaborative audio enhancement using probabilistic latent component sharing", in neural information processing systems (nips) 2014,

workshop on crowdsourcing and machine learning montreal, canada.

- [5] Robert c. Maher, "audio enhancement using nonlinear time-frequency filtering", AES 26th International Conference, Denver, Colorado, USA, pp 1-9, 2005 July 7-9
- [6] Muhammad Ahsan and Tapio Saramaki, "A MATLAB Based Optimum Multiband FIR Filters Design Program Following the Original Idea of the Remez Multiple Exchange Algorithm. Academy of Finland, project No. 213462 (Finnish Centre of Excellence program (2006 - 2011), 2011 IEEE
- [7] Xi Zhang, Senior Member, IEEE, Akira Kato, Toshinori Yoshikawa, "A New Class of Orthonormal Symmetric Wavelet Bases Using a Complex Allpass Filter", *IEEE Transactions on Signal Processing*, vol. 49, no. 11, november 2001
- [8] Xi Zhang, "A New Phase-Factor Design Method for Hilbert-Pairs of Orthonormal Wavelets", *IEEE Signal Processing Letters*, vol. 18, no. 9, september 2011
- [9] James H. McClellan, Thomas W. Parks, "A Personal History of the Parks-McClellan Algorithm", *IEEE Signal Processing Magazine* march 2005
- [10] Xiaolin SHI, "A Pulse Design Method for the Compatibility of UWB and IEEE 802.11a WLAN Systems", 2011 International Conference on Network Computing and Information Security
- [11] Lai Xiaoping, "An OP-Remez Approach to the Design of FIR Digital Filters" Proceedings of ICSP2000
- [12] Xi Zhang, "Design of FIR Halfband Filters for Orthonormal Wavelets Using Remez Exchange Algorithm", *IEEE Signal Processing Letters*, vol. 16, no. 9, september 2009
- [13] O. Rioul, P. Duhamel, "A Remez Exchange for Orthonormal Algorithm Wavelets", *IEEE Transactions on Circuits and Systems-11: analog and digital signal processing*, vol. 41, no. 8, august 1994