

# Design and Verification of BERT with New Proposed MIMO Encoder using FPGA

1Pragati Soni, 2Prof.Mohit Khilwani  
TIET, Jabalpur.

**Abstract:** These paper represent a generalization of Space-Time Codes from orthogonal designs. Particularly, we show in this work, that not only the Alamouti-scheme which was useful only for OSTBC for two transmit antennas, but also its generalized version achieves capacity in the case of one receive antenna. The drafted codes are then analyzed with respect to the bit error rate performance and the spectral efficiency with optimal as well as suboptimal receiver structures. In the second part of this work the combination of Space-Time Codes with conventional channel coding techniques is considered. New OSTBC is presented and the performance of Space-Time Codes with iterative algorithms for soft-input-soft-output-decoding is analyzed and optimized with the help of Xilinx Integrated Simulation Environment, the coding part is done in VHDL and the synthesis of work is been develop on Xilinx 12.2. the obtain results are been compared with base works and found better.

**Keywords:** OSTBC: Orthogonal Space Time Block Coding, MIMO: Multiple Input Multiple Output OFDM: Orthogonal Frequency Division Multiplexing, QSTBC: Quasi Orthogonal STBC, ISI: Inter Symbol Interference, ICI: Inter Carrier Interference

## I-INTRODUCTION

Orthogonal frequency division multiplexing (OFDM) is a method of encoding digital data on multiple carrier frequencies. OFDM has developed into a popular scheme for wideband digital communication, used in applications such as digital television and audio broadcasting, DSL Internet access, wireless networks, power-line networks, and 4G mobile communications. Orthogonal frequency division multiplexing (OFDM) is considered as a one of the best modulation schemes in wireless communications. However, OFDM suffers from the sensitivity to frequency offset. This frequency offset introduces the problem of inter-carrier interference (ICI) in OFDM system.

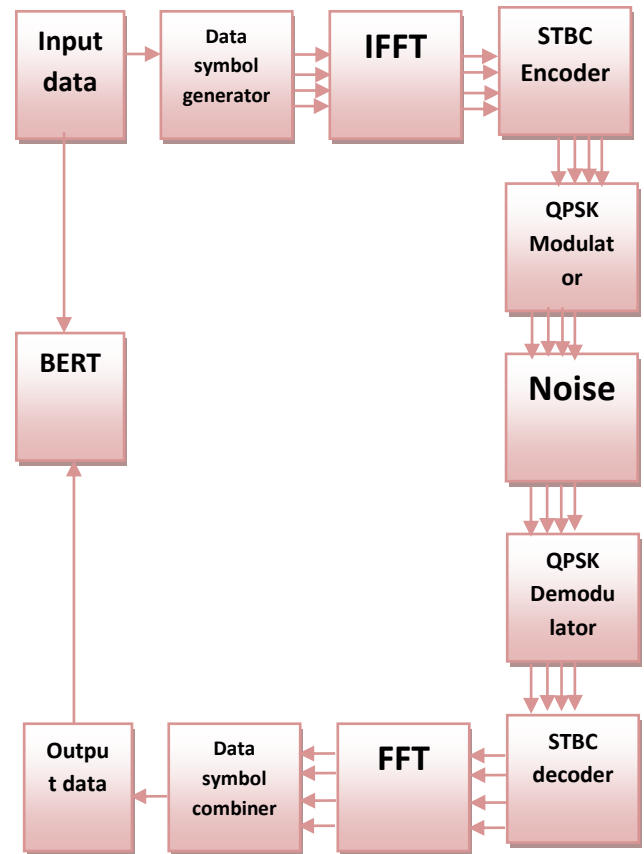

Figure 1 OFDM system

Figure 1.1 above shows the OFDM system block diagram each module is explained below

**Input data:** it is original signal which is to be transmitted.

**Data symbol Generator:** this module will convert the input data signal into symbols it is serial to parallel converter.

**IFFT:** it convert frequency domain signal into time domain signal before signal transmission and encoding.

**STBC Encoder:** it encode the time domain signal symbols in such a way that this signal transmitted from different antennas at different time slot remains orthogonal to each other.

**QPSK Modulator:** this is a modulator which modulates the signals so it can transmit to a long distance.

**Noise:** in the wireless channel the noise may introduce because of many reasons with any strength this can be AWGN or random noise.

**QPSK Demodulator:** this is a demodulator which receive modulated signal and extract the encoded signal symbols out of it.

**STBC decoder:** this module decodes the encoded symbols and develops original signal symbols.

**FFT:** this converts time signal into frequency signals

**Data symbols combiner:** it is basically a parallel to serial converter which develop signal from signal symbols.

**BERT:** it is Bit Error Rate tester to check change in number of bits between transmitted signal and received signal.

In MIMO Inter Carrier Interference (ICI) happens between the parallel data on different channel and Inter Symbol Interference (ISI) happens between multiple symbols on single channel, this problem of MIMO can be handle by using OFDM, OFDM requires STBC coder for encoding the different symbols, STBC of OFDM tells us what symbol should be transfer from which antenna at which time slot. But achieving full orthogonality with full rate of communication is possible with Alamouti code only for 2x2 transmit and receive antenna till data. But if we use only two antennas it will transfer less data and if we go for more than two antenna achieving orthogonality with full rate is not possible by any available encoding technique, orthogonality for less than full rate is been achieved but for full rate not been achieved. So if we go for more than two antennas and consider full rate there will be problem of ICI and ISI will appear and this will cost significant enhancement in BER.

**SPACE-TIME CODING SYSTEM:** A typical communication system consists of a transmitter, a channel, and a receiver. Space-time coding involves use of multiple transmit and receive antennas, as illustrated in Fig. 2 Bits entering the space-time encoder serially are distributed to parallel sub-streams. Within each sub-stream, bits are mapped to signal waveforms, which are then emitted from the antenna corresponding to that sub-stream. The scheme used to map bits to signals is the called a space-time code. Signals transmitted simultaneously over each antenna interfere with each other as they propagate through the wireless channel. Meanwhile, the fading channel also distorts the signal waveforms. At the receiver, the distorted and superimposed waveforms detected by each receive antenna are used to estimate the original data bits.

Space-time coding is an effective approach to improve the reliability of data transmission as well as the data rates over multiple-input multiple-output (MIMO) fading wireless channels. In this thesis, space-time code designs are investigated with a view to address practical concerns such as decoding complexity and channel impairments. We study low-decoding complexity space-time block codes (STBC), a popular subclass of space-time codes, for quasi-static frequency-flat fading MIMO channels. Therefore, the space-time code matrices are designed to allow the separation of transmitted symbols into groups for decoding; we call these codes multi-group decodable STBC.

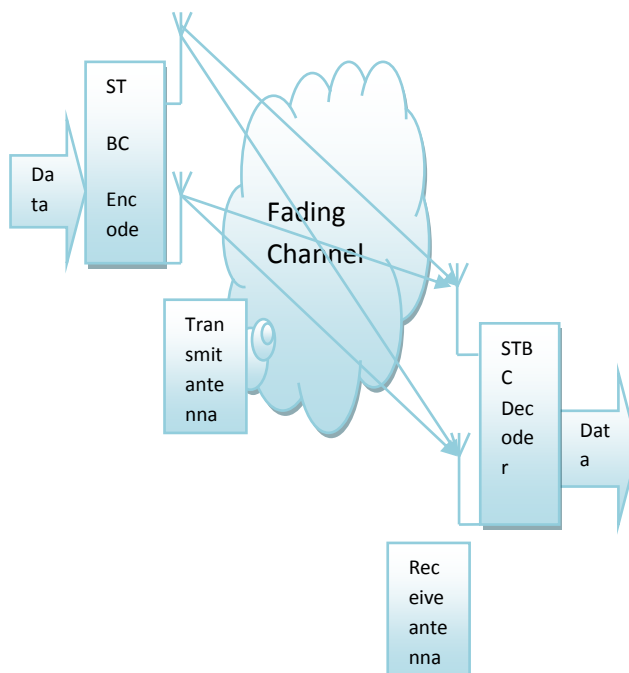

Fig 2 A typical communication system utilizing space-time coding

## II-LITERATURE REVIEW & PROBLEM FORMULATION

Paper by	Outcomes	Results
Amirhossein Alimohammadal	They presented BERT for a typical single- and multiple-antenna digital baseband communication system on a single FPGA, Their BERT system is flexible enough to be reconfigured for adapting the new	1343 slices of vertex FPGA frequency achieved 52 Mhz

	specifications of emerging standards and is scalable to support various configurations.	
<b>Lakshmy Sukumar et al [2]</b>	They use different coding schemes and different modulations on FPGA. A user friendly GUI been developed through which the parameters of the BERT can be altered, as per choice.	1437 slices of vertex FPGA
<b>Annie Xiang et al [3]</b>	A custom FPGA-based bit error rate tester was developed to characterize and validate a serial optical Link, A number of coding schemes and transmission protocols were explored	156.25 MHz
<b>Arun Kumar et al[4]</b>	Describes the Design and Implementation of Phase Shift keying (PSK) Modulation and demodulation in FPGA using Partial Re-configuration (PR). This work involves the Design and implementation of BPSK, QPSK, 8-PSK and 16-PSK modulation and demodulation schemes in FPGA.	574 slice of vertex FPGA for demodulator design

**Table 1 literature survey**

**PROBLEM FORMULATION:** In recent years, goal of providing high speed wireless data services it generated a great amount of interest among research community. Space time block codes with orthogonal structures typically provide full-diversity reception and simple receiver processing. However, rate-1 orthogonal codes for complex constellations have not been found for more than two transmit antennas. By using a genetic algorithm, rate-1 space-time block codes that accommodate very simple receiver processing at cost of reduced diversity are designed in this paper for more than two transmit antennas. Simulation results show that evolved codes combined with efficient outer codes provide better rendering over fading

channels than minimum-decoding-complexity quasi-orthogonal codes at typical operating signal-to-noise ratios. When fading is more severe than Rayleigh fading, spectral efficiency is specified, and an efficient outer code is used, evolved codes outperform orthogonal space-time block codes. It has been shown that a complex orthogonal design that provides full diversity and full transmission rate for a space-time block code is not possible for more than two antennas. Previous attempts have been concentrated in generalizing orthogonal designs which provide space-time block codes with full diversity and a high transmission rate. In this work, proposed work design rate one codes which are quasi-orthogonal and provide partial diversity. Decoder of proposed codes works with pairs of transmitted symbols instead of single symbols. Standard approach to design of individual space-time codes is based on optimizing diversity and coding gains. This geometric approach leads to remarkable examples, such as perfect space-time block codes, for which complexity of Maximum Likelihood (ML) decoding is considerable. Code diversity is an alternative and complementary approach where a small number of feedback bits are used to select from a family of space-time codes. Different codes lead to different induced channels at receiver, where Channel State Information (CSI) is used to instruct transmitter how to choose code. This method of feedback provides gains associated with beam-forming while minimizing number of feedback bits. Thus code diversity can be viewed as integration of space-time coding with a fixed set of beams. It complements standard approach to code design by taking advantage of different (possibly equivalent) realizations of a particular code design.

### III- IMPLEMENTATION

Proposed design is a full system of OFDM module developed on FPGA here in proposed work four transmitter and four receiver antennas is been used, and to reduce the BER, it is highly requires to reduce the ICI (inter carrier interface) and ISI (inter symbol interface).

Alamouti scheme represent and prove if transmitted symbols are orthogonal to each other the impact of ICI and ISI get negligible but only issue was to maintain the orthogonality for more than two antennas for full rate (rate-1), though methods available achieved  $\frac{4}{3}$  and  $\frac{3}{4}$  rate for full orthogonal communication of symbols. Proposed design is another QSTBC solution of the orthogonality issue in full rate but with less BER than available methods. Proposed design also design a new FSM based PSK demodulator.

**OFDM SYSTEM:** Proposed OFDM module has two major block OFDM transmitter and OFDM receiver. OFDM transmitter has four major parts decomposer, IFFT, STBC encoder and PSK where the PSK is been used four time for providing four antenna space diversity. PSK modulator has another four modules inside it, TR, TRM, Generator and clock counter.

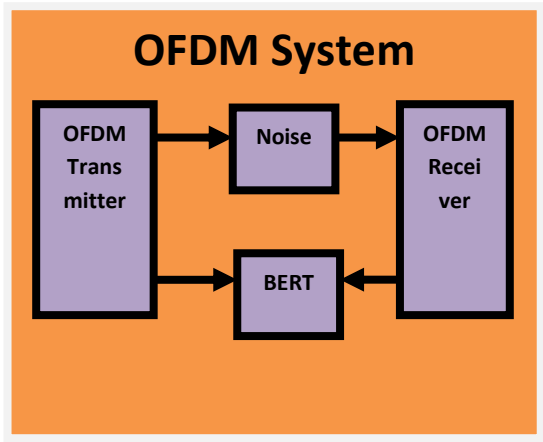

Figure 3 OFDM System

OFDM receiver part is using four major modules FFT, STBC decoder, Combiner and PSK demodulator used four times for providing four receiver antenna space diversity, PSK demodulator has four components FSM, clock control, data generator and signal generator.

**OFDM Transmitter:** This module is a design which integrate decomposer, IFFT, STBC encoder and PSK as shown in figure below

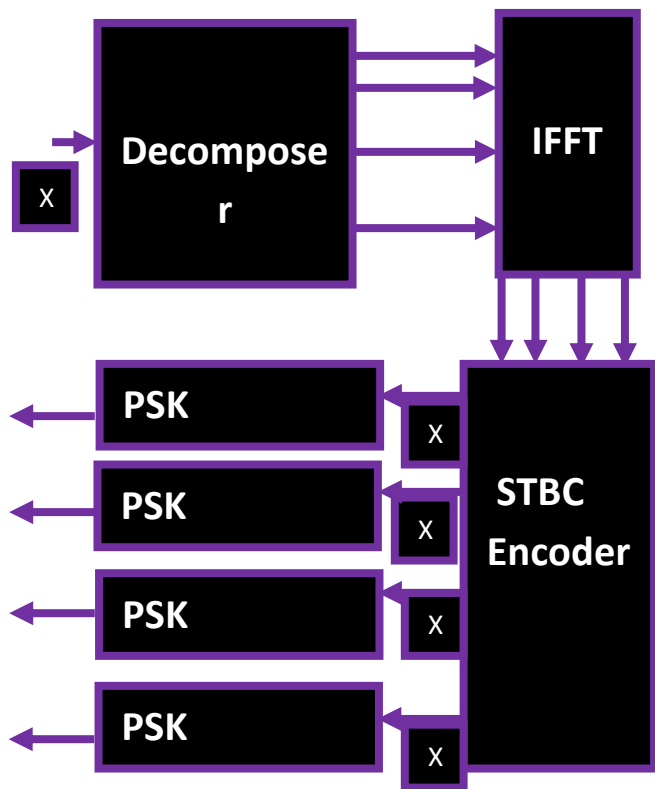

Figure 4 Proposed OFDM transmitter

**Decomposer:** this is the module which works as serial to parallel convertor and generate symbols from the input signals.

**IFFT:** this block is developed for converting frequency domain signal into time domain

**STBC Encoder:** STBC can efficiently achieve transmit diversity to combat fading. By using orthogonality of transmitted symbols, Alamouti first defined a space time transmission matrix as:

$$A_{12} = \begin{bmatrix} X_1 & X_2 \\ -X_2^* & X_1^* \end{bmatrix}$$

Based on Alamouti orthogonal STBC, proposed gave a quasi-orthogonal STBC form for four transmit antennas as:

$$C_J = \begin{bmatrix} A_{12} & A_{34} \\ -A_{34}^* & A_{12}^* \end{bmatrix} = \begin{bmatrix} X_1 & X_2 & X_3 & X_4 \\ -X_2^* & X_1^* & -X_4^* & X_3^* \\ -X_3^* & -X_4^* & X_1^* & X_2^* \\ X_4 & -X_3 & -X_2 & X_1 \end{bmatrix}$$

Its character matrix it similar fashion as sparse matrix pattern, and proposed work can write it as:

$$C_J^H C_J = \begin{bmatrix} a & 0 & 0 & B_J \\ 0 & a & -B_J & 0 \\ 0 & -B_J & a & 0 \\ B_J & 0 & 0 & a \end{bmatrix}$$

Where  $C^H$  is Hermitian of matrix  $C$ ,  $a = \sum_{i=1}^4 x_i^2$ , and correlated value is  $b_j = (x_1 x_4 + x_1^* x_4^*) - (x_2 x_3 + x_3^* x_2^*)$  a real number, and it is lesser compare with available QSTBC methods to reduce BER.

**QPSK Modulator:** design for PSK module which we are using for generation of symbols for the Orthogonal Encoder its been developed and Verified on Xilinx EDA.

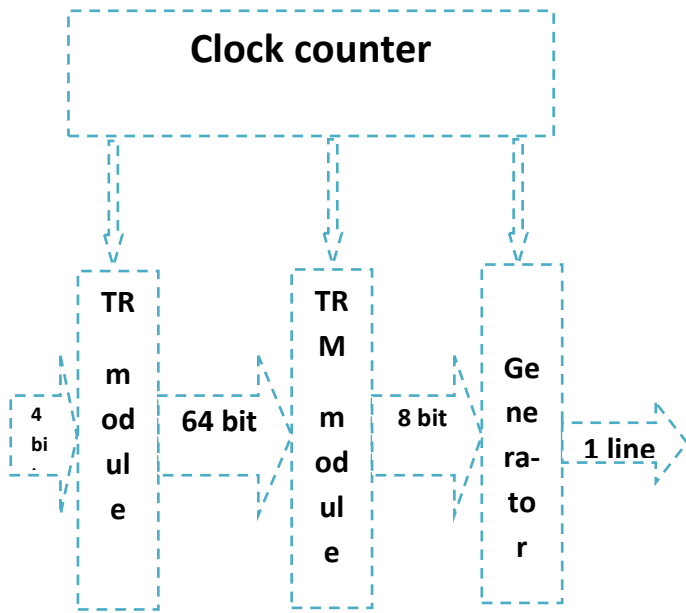

Figure 5 Proposed QPSK Modulator

Figure above is the proposed modulator where Module 'clkcounter' is there for generating control signals and these control signals provides proper synchronisation between other modules. Module 'tr' receives four bit input of digital signal which can be any one quantized level of digital input signal, because a complete cycle of any signal can have 16 time intervals so it receives total 64 input bit and ones it receives 64 bit it consider it as one cycle and pass these 64 bits to next module and starts receiving next inputs. Module 'trm' gets 64 bit input which is a complete cycle of input it observe the patterns and recognise the phase difference from the last received cycle as per that observation it generates a 8 bit encoded output signal which is actually a patterns of phase difference in 8 bit parallel form of PSK. Module 'generator' gets 8 bit encoded input and it simply converts that 8 bit parallel form of PSK into serial single line PSK output.

IV-RESULT

Device Utilization Summary (estimated values)			
Logic Utilization	Used	Available	Utilization
Number of Slices	1194	4656	25%
Number of Slice Flip Flops	976	9312	10%
Number of 4 input LUTs	2043	9312	21%
Number of bonded IOBs	43	158	27%
Number of MULT18K10000s	6	20	30%
Number of GCLKs	2	24	8%

Table 2: Synthesis results

Table above shows the obtain results it shows the number of slice uses as know the number of slice is area requirement and obtain 274 slice is very low as per already developed OFDM modules for BERT and also shows the no of flip flops. Figure below is the RTL view of the proposed work; this represents the logical connections of the proposed module. Figure 6 below id the RTL view of the proposed OFDM BERT, figure 7 and figure 8 below are the simulation results observed for the proposed work.

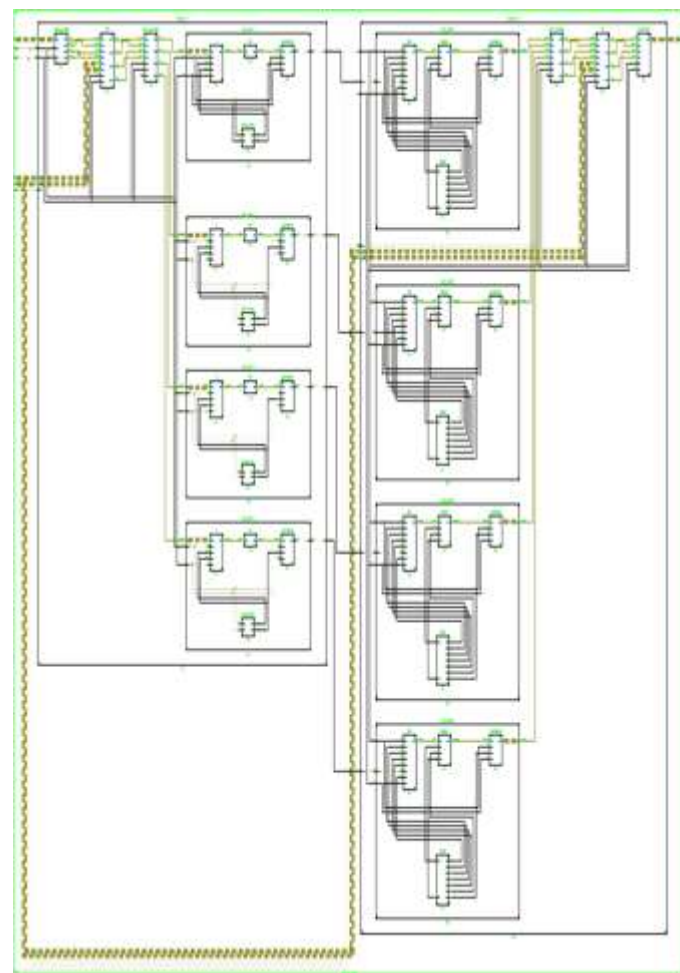

Figure 6 :RTL view of the OFDM -BERT

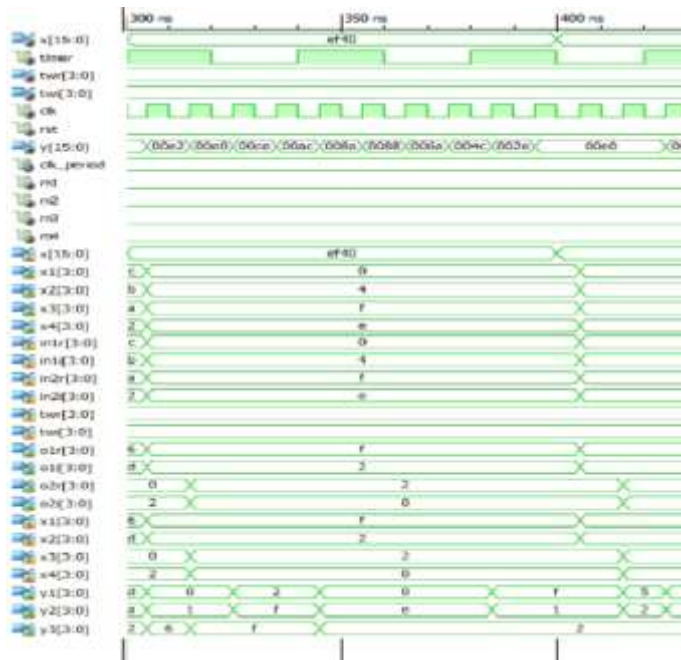

Figure 7 : simulation of the proposed work OFDM-BERT

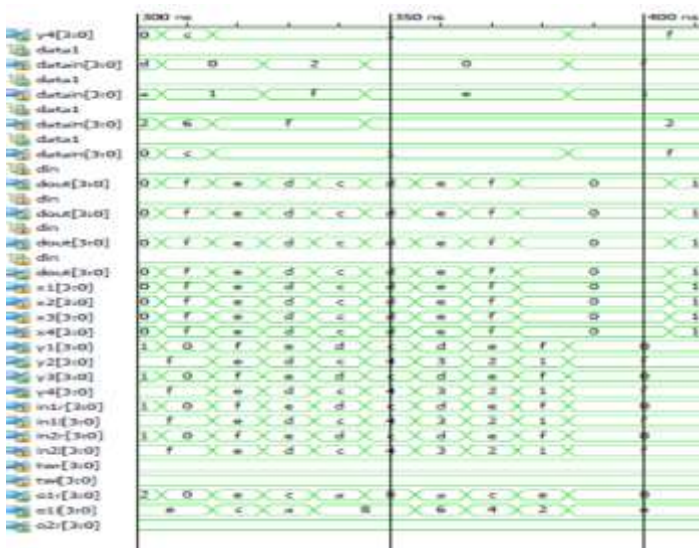

Figure 8 : simulation of the proposed work OFDM-BERT

**V-CONCLUSION**

We have designed space-time codes for MIMO and full OFDM system and it s BERT tester systems considering the practical constraints such as decoding complexity and system imperfections. While reduction in decoding complexity leads to power and manufacturing cost savings, mitigating the system imperfections is necessary to prevent possible transmission errors. The necessary and sufficient conditions for low decoding complexity STBC are proposed

for quasi-static frequency-flat MIMO fading channels. To achieve low complexity, we have developed multi-group decodable STBC. For a fixed number of transmitted symbols encoded in a code matrix, an increase in the number of groups leads to lower decoding complexity.

**References**

[1] Amirhossein Alimohammad and Saeed Fouladi Fard, FPGA-Based Bit Error Rate Performance Measurement of Wireless Systems, IEEE TRANSACTIONS ON VERY LARGE SCALE INTEGRATION (VLSI) SYSTEMS, VOL. 22, NO. 7, JULY 2014, pp 1583

[2] Lakshmy Sukumaran1, Dharani K G , implementation of a bit error rate tester of a wireless communication system on an fpga, ijret: International Journal of Research in Engineering and Technology eISSN: 2319-1163, pISSN: 2321-7308

[3] Annie Xiang, Datao Gong, Suen Houb, Chonghan Liu, Futian Liang, Tiankuan Liu, Da-Shung Su, Ping-Kun Tengb, Jingbo Ye, Design and verification of an FPGA-based bit error rate tester, TIPP 2011 - Technology and Instrumentation in Particle Physics, 2012 Published by Elsevier

[4] Adaptive Modulation Performance In Mimo- OSTBC Over Rayleigh Fading Channel, by Mr. R.O. Abolade and Mr. Z. K. Adeyemo, International Journal of Engineering & Computer Science IJECS-IJENS Vol:12 No:06, 1217605 December 2012

[5] "Performance analysis of LDPC codes with maximum-ratio combining cascaded with selection combining over Nakagami-m fading, by Mr. B. S. Tan, K. H. Li, and K. C. Teh," *IEEE Trans. Wireless Commun.*, vol. 10, no. 6, pp. 1886–1894, Jun. 2011.

[6] "Performance analysis of generalized selection combining with threshold test per branch (T-GSC)," by Mr. M. K. Simon and Mr. M.-S. Alouini, *IEEE Trans. Veh. Technol.*, vol. 51, no. 5, pp. 1018–1029, Sep. 2002.

[7] "Asymptotic performance of thresholdbased generalized selection combining, by Mrs. Y. Ma, Mr. X. Dong, and Mr. H.-C. Yang," *IEEE Trans. Veh. Technol.*, vol. 58, no. 5, pp. 2579–2585, Jun. 2009.

[8] "Minimum selection GSC and adaptive low-power RAKE combining scheme," by Mr. S. W. Kim, Mr. D. S. Ha, and Mr. J. H. Reed, in *Proc. IEEE ISCAS*, vol. 4, pp. IV-357–IV-360.

[9] Lennert Jacobs and Marc Moeneclaey, Accurate BER Approximation for OSTBCs With Estimated CSI in Correlated Rayleigh Fading, Wireless Communications and Networking Conference (WCNC): IEEE, 2013

[10] Saliya Jayasinghe L. Keeth, , Noncoherent Amplify-and-Forward MIMO Relaying With OSTBC Over Rayleigh-Rician Fading Channels, vehicular technology, IEEE transactions, vol. 62, no. 4, may 2013

[11] Saikat Ghosh ,K.V.N. Kavitha,, Ankit Keetey, Error Rate Analysis of STBC-OFDM System with Efficient Channel Coding Technique at low SNR , International Journal Applied Engineering Research, Volume 9, Number, 2014 pp. 3481-3494