

# Performance Analysis Of Multilevel Inverter Fed Three Phase Induction Motor Drive

#1 Kunal P. More

S.S.G.B.C.O.E & T BHUSAWAL, Maharashtra, India  
kunalmore717@yahoo.com

**Abstract**--Cascaded multilevel inverters synthesize a medium-voltage output based on a series connection of power cells which use standard low-voltage component. This characteristic give permission one to achieve high-quality output voltages and input currents and also outstanding availability due to their intrinsic component more than enough. Due to these features, the cascaded multilevel inverter has been recognized as an important alternative in the medium-voltage inverter market. This paper presents a survey of different geometric properties, control techniques used by these type inverters. Regenerative properties are also discussed. Applications where the mentioned features play a key role are shown. Finally, future developments

**Index Terms**—Multilevel inverter, Sinusoidal PWM technique, Diode clamp technique,.

## I. INTRODUCTION

Multilevel voltage-source inverters provide a cost-effective solution in the medium-voltage energy management market. These converters have been widely applied to chemical, oil, and liquefied natural gas (LNG) plants, water plants, marine propulsion, power generation, energy transmission, and power-quality devices. Procedure for Paper Submission Nowadays, there exist three commercial topologies of multilevel voltage-source inverters: neutral point clamped (NPC), cascaded H-bridge (CHB), and flying capacitors (FCs). Among these inverter topologies, cascaded multilevel inverter reaches the higher output voltage and power levels (13.8 kV, 30 MVA) and the higher reliability due to its modular topology.

Cascaded multilevel inverters are based on a series connection of several  $1\phi$  inverters. This configuration is capable to reaching medium output voltage levels using only standard low-voltage mature technology components. Typically, it is necessary to connect three to ten inverters in series to reach the required output voltage.

These converters also feature a high modularity degree because each inverter can be seen as a module with similar circuit topology, control structure, and modulation. Therefore, in the case of a fault in one of these modules, it is easy to replace it quickly. Moreover, with an appropriated control strategy, it is possible to bypass the faulty module without stop the load, bring an almost continuous overall availability.

This paper presents a bibliographical review of cascaded multicell inverters, its working principle, circuit topologies, control techniques, and industrial applications. This paper is organized as follows. Section II shows the working principle and basic and advanced topologies. Regenerative topologies and its control are addressed in Section III. In Section IV, several newly introduced topologies for cascaded inverters are shown. A group of applications is reviewed.

## III. ELECTRONIC CIRCUIT TOPOLOGY

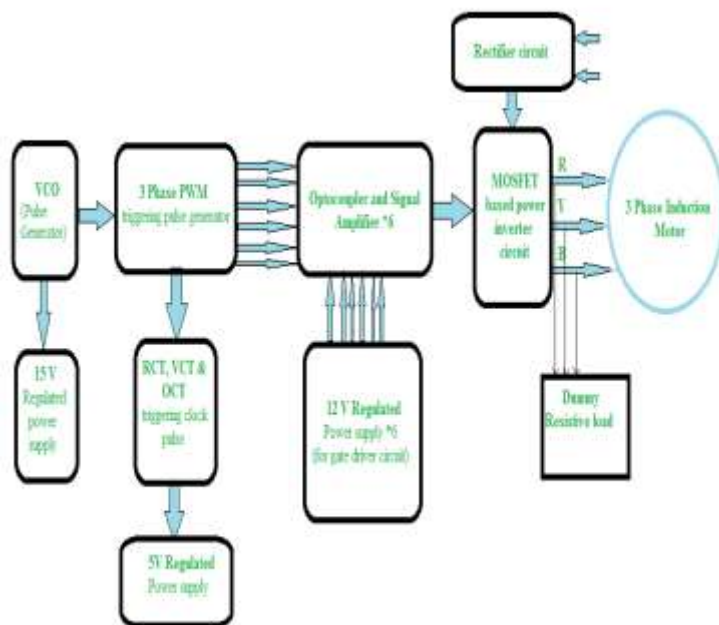

Fig. 1. Multilevel inverter based block diagram

Many current and future designs will incorporate the use of induction motors as the primary source for traction in electric vehicles. Designs for heavy duty trucks and many military combat vehicles that have large electric drives will require advanced power electronic inverters to meet the high power demands (>250 kw). Development of electric drive trains for these large vehicles will result in increased fuel efficiency, lower emissions, and likely better vehicle performance (acceleration and braking). Multilevel inverters are uniquely suited for these applications because of the high VA ratings possible with these inverters.



Fig. 2. Multilevel inverter based drive circuit.

### II. OPERATING PRINCIPLE

To produce a staircase-output voltage, consider one leg of the three-level inverter, as shown in Fig.3. The steps to synthesize the three-level voltages are as follows

1. For an output voltage level  $V_{ao}=V_{dc}$ , turn on all upper-half switches  $A_1$  and  $A_2$ .
  2. For an output voltage level  $V_{ao}=V_{dc}$ , turn on one upper switch  $A_2$  and one lower switch  $A_1'$ .
  3. For an output voltage level  $V_{ao}=0$ , turn on all lower half switches  $A_1'$  and  $A_2'$ .
- tain constant motor flux.

#### Control Mechanism

The voltage and frequency being increased up to the base speed. At base speed, the voltage and frequency reach the rated values. We can drive the motor beyond base speed by increasing the frequency further. But the voltage applied cannot be increased beyond the rated voltage. Therefore, only the frequency can be increased, which results in the field weakening and the torque available being reduced. Above base speed, the factors governing torque become complex, since friction and windage losses increase significantly at higher speeds. Hence, the torque curve becomes nonlinear with respect to speed or frequency.

#### Modulation of circuit

This Paper mainly focuses on multicarrier PWM method. This method is simple and more flexible than SVM methods. the inverter. Multicarrier PWM method can be categorized into two groups: 1) Carrier Disposition (CD) method 2) Phase shifted PWM method.

Advantages of multicarrier PWM techniques:

- Easily extensible to high number of levels.

- Easy to implement.
- To distribute the switching signals correctly in order to minimize the switching losses. To compensate unbalanced dc sources. Related to the way the carrier waves are placed in relation to the reference signal, three cases can be distinguished Output line-line voltage for 50Hz frequency.

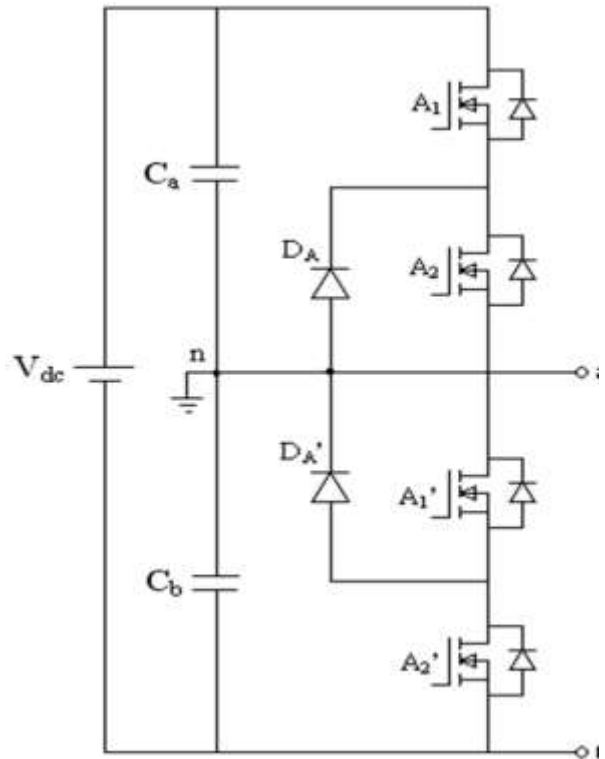

Fig. 3. Principle of operation





Fig. 4. Output line-line voltage for 50Hz frequency.

#### IV.RESULT

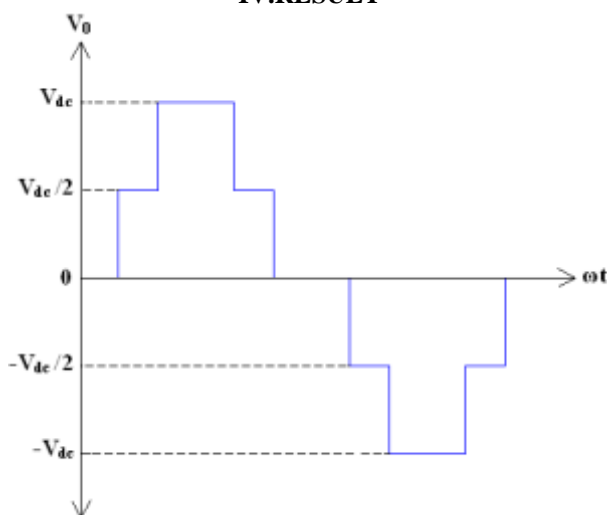

Fig. 5. Three level inverter output voltage.

#### V. CONCLUSION

A diode clamped multilevel inverter has been presented for drive applications. The multicarrier PWM technique can be implemented for producing low harmonic contents in the output, hence the high quality output voltage was obtained. The open loop speed control was achieved by maintaining  $V/f$  ratio at constant value. The simulation results show that the proposed system effectively controls the motor speed and enhances the drive performance through reduction in total harmonic distortion (THD). This drive system can be used for variable speed applications like conveyors, rolling mills, printing machines etc.

#### REFERENCES

- 1) A. K. Gupta and A. M. Khambadkone, "A general space vector PWM algorithm for multilevel inverters, including operation in overmodulation range," *IEEE Trans. Power Electron.*, vol. 22, no. 2, pp. 517–526, Mar. 2007.
- 2) C. Rech and J. R. Pinheiro, "Hybrid multilevel converters: Unified analysis and design considerations," *IEEE Trans. Ind. Electron.*, vol. 54, no. 2, pp. 1092–1104, Apr. 2007.
- 3) A. K. Gupta and A. M. Khambadkone, "A space vector modulation scheme to reduce common mode voltage for cascaded multilevel inverters," *IEEE Trans. Power Electron.*, vol. 22, no. 5, pp. 1672–1681, Sep. 2007.
- 4) A. Das, K. Sivakumar, R. Ramchand, C. Patel, and K. Gopakumar, "A combination of hexagonal and 12-sided polygonal voltage space vector PWM control for IM drives using cascaded two-level inverters," *IEEE Trans. Ind. Electron.*, vol. 56, no. 5, pp. 1657–1664, May 2009.
- 5) R. Gupta, A. Ghosh, and A. Joshi, "Switching characterization of cascaded multilevel-inverter-controlled systems," *IEEE Trans. Ind. Electron.*, vol. 55, no. 3, pp. 1047–1058, Mar. 2008.
- 6) N. S. Choi, J. G. Cho, and G. H. Cho, "A general circuit topology of multilevel inverter," in *Proc. IEEE PESC'91*, 1991, pp. 96–103.
- 7) Jose, Steffen Sernet, Bin Wu, Jorge and SamirKouro, "Multilevel Voltage – Source -Converter Topologies for Industrial Medium - Voltage Drives," *IEEE Trans on Industrial Electronics*, vol.54, no.6, Dec 2007.
- 8) Dr.Rama Reddy and G.Pandian, "Implementation of Multilevel inverter fed Induction motor Drive," *Journal of Industrial Technology*, vol 24, no. 1, April 2008.
- 9) Nikolaus P. Schibli, T. Nguyen, and Alfred C. Rufer, "A Three-Phase Multilevel Converter for High - Power Induction Motors," *IEEE Trans on Power Electronics*, vol.13, no.5, Sept 1998.
- 10) N.Celanovic and D.Boroyevich, "A Comprehensive study of neutral-pointvoltage balancing problem in three-level neutral – pointclamped voltage source PWM inverters," *IEEE Trans on Power Electronics*, vol.15, no. 2, pp. 242 – 249, March 2000.
- 12) Fang Zheng Peng, "A Generalized Multilevel Inverter Topology with Self Voltage Balancing," *IEEE Trans on Ind. Appl.*, vol. 37, no. 2, pp 611-618 Mar/April 2001.