

# Design and Performance Analysis of LCL Filter in Grid Interconnected System

Kandur Prashanth Kumar<sup>1</sup>, Rosaiah Mudigondla<sup>2</sup>

<sup>1</sup>PG Scholar, Dept. of EEE, ARJUN COLLEGE OF TECH & SCIENCE, RANGAREDDY (DT), INDIA,

<sup>2</sup>HOD, Dept. of EEE, ARJUN COLLEGE OF TECH & SCIENCE, RANGAREDDY (DT), INDIA,

<sup>1</sup>Email: [prashanth2891@gmail.com](mailto:prashanth2891@gmail.com)

<sup>2</sup>Email: [rosaiah0228@gmail.com](mailto:rosaiah0228@gmail.com)

**Abstract:** Aiming at the problem of filtering in the grid-connected inverters, the mathematics models for LCL filter are established. The values of capacitances and inductances are calculated by analyzing the related constraint conditions for the main parameters of LCL filter. There are two ways to increase the value of damping resistor of the filter capacitor. The impacts on the stability and filtering property, in both ways, are analyzed. The use of power converters is very important in maximizing the power transfer from renewable energy sources such as wind, solar, or even a hydrogen-based fuel cell to the utility grid. An LCL filter is often used to interconnect an inverter to the utility grid in order to filter the harmonics produced by the inverter. Although there is an extensive amount of literature available describing LCL filters, there has been a gap in providing a systematic design methodology. Furthermore, there has been a lack of a state-space mathematical modeling approach that considers practical cases of delta- and wye-connected capacitors showing their effects on possible grounding alternatives. This project describes a design methodology of an LCL filter for grid-interconnected inverters along with a comprehensive study of how to mitigate harmonics.

**Keywords:** LCL filter, Delta- and Wye-Connected Capacitors, Grid-Interconnected Inverters.

## I. INTRODUCTION

With the energy crisis and environment revolution are becoming more and more serious, renewable power generation system is drawing more and more attention. We vigorously developed clean energy such as wind, and solar power. The control technology of grid-connected inverter is the key technology in renewable power generation. In the grid-connected inverter, the all-controlled power electronic devices IGBT and GTO are used, which is modulated by the high frequency PWM. As the result, the  $du/dt$  and  $di/dt$  are ever large. Due to the presence of some vagrant parameters, the current included high order harmonic flow into the power grid, which made the harmonic pollution? The most common filter is L in the grid-connected inverter. In order to decrease current ripple, the inductance have to be increased. As a result, the volume and weight of the filter increased. Although the structure and the parameter of the LC filter are easy, the filtering effect is not good because of the uncertainty of network impedance. LCL filter had an inherently high cut-off frequency and strong

penetrating ability in low frequency. So LCL filter has come into wide use in the inverter. What is the most difficult is that how to select the parameter and control resonance. In this paper, with the three-phase PV grid-connected inverters topology, firstly analyze the inductance, the ration of two inductances, selecting the filter capacitor and resonance resistance. Based on these theories, a LCL filter is designed. The simulation result proved that the LCL filter achieve the best performance, and indicated the impacts on the stability and filtering property from the parallel resistor or the series resistor.

## II. RELATED WORKS

Commonly, a high-order LCL filter has been used in place of the conventional L filter for smoothing the output currents from a VSI [1], [2]. The LCL filter achieves a higher attenuation along with cost savings, given the overall weight and size reduction of the components. LCL filters have been used in grid-connected inverters and pulse width-modulated (PWM) active rectifiers [1]–[3] because they minimize the amount of current distortion injected into the utility grid [4]. Good performance can be obtained in the range of power levels up to hundreds of kilowatts, with the use of small values of inductors and capacitors [3]. The higher harmonic attenuation of the LCL filter allows the use of lower switching frequencies to meet harmonic constraints as defined by standards such as IEEE-519 and IEEE-1547 [5], [6]. However, it has been observed that there is very little information available describing the systematic design of LCL filters. In order to design an effective LCL filter, it is necessary to have an appropriate mathematical model of the filter. In this paper, the output filter modeling, filter-designing procedures, and considerations of the passive damping requirements will be thoroughly discussed.

## III. EXISTING SYSTEM

Voltage-source inverters (VSIs) are used for energy conversion from a dc source to an ac output, both in a stand-alone mode or when connected to the utility grid. A filter is required between a VSI and the grid. L filter design for smoothing the output current imposing a current-like performance for feedback control and reducing harmonics of the

output current. The objective of this paper is to conduct a comprehensive analysis and modeling of the three-phase LCL filter for non galvanic isolated inverters, suitable for wind energy or photovoltaic applications. Two configurations of three-phase full-bridge dc/ac inverter are compared: first, a set of wye connected filter capacitors with damping and, second, a delta connected filter output connection.

**A. Principle of LCL Filter**

The classical topological structure is shown in Fig.1. This topology is general use in three-phase PV grid-connected inverters. Where dc U is the voltage of DC bus, dc I is the current of DC bus, S1~S6 six-switch made up three-phase inverter, 1 L, s C, 2 L made up third-order LCL filter[1].

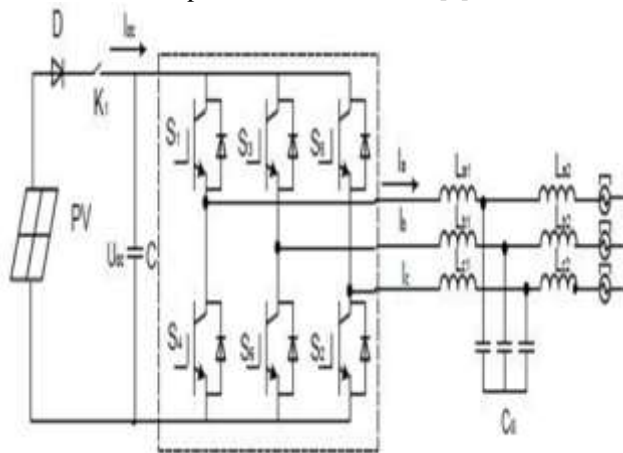

**Fig.1. Topological structure of three-phase PV grid-connected inverters with LCL filter.**

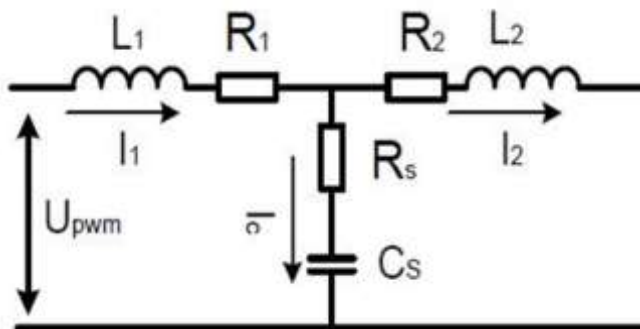

**Fig. 2. Circuit diagram of LCL filter.**

The internal resistances of inductance and capacitance are negligible. The transfer-function of the I2 to U\_pwm is given as

$$G(s) = \frac{I_2}{U_{pwm}} = \frac{1}{s^3 L_1 L_2 C + (L_1 + L_2) s} \quad (1)$$

Where, I2 is the output current of LCL filter, U\_pwm is the output voltage of PWM. The transfer-function of L filter is given as

$$G(s) = \frac{I_2}{U_{pwm}} = \frac{1}{Ls} \quad (2)$$

The first-harmonic, low order harmonic and high order harmonic current could be got by decomposing the output current of inverter. As shown in Fig. 2, the current ripple is decreased because of inductance L1 that the current flow through. The capacitance is features low resistance to high order harmonic, but the inductance is features high resistance, so the high order harmonic can only flow through capacitance. Then the left current of first-harmonic and low order harmonic flow through inductance L2 into power grid.

**IV. PROPOSED ARCHITECTURE**

**A. Introduction**

The objective of this paper is to conduct a comprehensive analysis and modeling of the three-phase LCL filter for non galvanic isolated inverters, suitable for wind energy or photovoltaic applications. In this project, the output filter modeling, filter-designing procedures, and considerations of the passive damping requirements will be thoroughly discussed. LCL filters have been used in grid-connected inverters and PWM active rectifiers. Because they minimize the amount of current distortion injected into the utility grid. LCL filter design The LCL filter achieves a higher attenuation along with cost savings, given the overall weight and size reduction of the components. LCL filters have been used in grid-connected inverters and pulse width-modulated (PWM) active rectifiers because they minimize the amount of current distortion injected into the utility grid. Good performance can be obtained in the range of power levels up to hundreds of kilowatts, with the use of small values of inductors and capacitors.

The following per-phase equivalent model has been fully described in an earlier paper written by the authors. The LCL filter model is where L1 is the inverter side inductor, L2 is the grid-side inductor, Cf is a capacitor with a series Rf damping resistor, R1 and R2 are inductors resistances, and voltages vi and vg are the input and output (inverter voltage and output system voltage). A functional block diagram for the grid-connected inverter using this LCL filter is shown in Fig. 3.

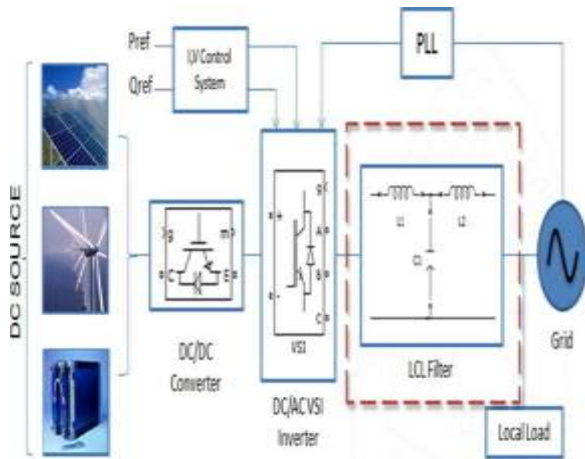

Fig.3. Per-Phase Equivalent Modeling of an LCL Filter

**B. Filter Design Procedure**

For the design of the filter capacitance, it is considered that the maximum power factor variation seen by the grid is 5%, indicating that the base impedance of the system is adjusted as follows:  $C_f = 0.05C_b$ . A design factor higher than 5% can be used, when it is necessary to compensate the inductive reactance of the filter. Several characteristics must be considered in designing an LCL filter, such as current ripple, filter size, and switching ripple attenuation. The reactive power requirements may cause a resonance of the capacitor interacting with the grid. Therefore, passive or active damping must be added by including a resistor in series with the capacitor. In this paper, the passive damping solution has been adopted, but active solutions can be also applied. The algorithm for designing the LCL filter is indicated in the example below, the filter design steps are described in detail. The following parameters are needed for the filter design:  $V_{LL}$ , line-to-line RMS voltage (inverter output);  $V_{ph}$ , phase voltage (inverter output);  $P_n$ , rated active power;  $V_{DC}$ , dc-link voltage;  $f_g$ , grid frequency;  $f_{sw}$ , switching frequency; and  $f_{res}$ , resonance frequency. The base impedance and the base capacitance are defined by below equation. Thus, the filter values will be referred to in a percentage of the base values, i.e.

$$Z_b = \frac{E_n^2}{P_n}$$

$$C_b = \frac{1}{\omega_g Z_b} \tag{3}$$

**Wye-Connected Capacitors:** The LCL filter state-space model with wye-connected capacitors is derived from the per-phase model

$$\dot{x} = Ax + Bu. \tag{4}$$

**Delta-Connected Capacitors:** An LCL filter with delta-connected capacitors can be analyzed in the abc stationary frame with the circuit. The voltages

and currents can be formulated as given by equations

$$V_{AB} + V_{BC} + V_{CA} = 0 \tag{5}$$

**LCL Frequency Response:** An important transfer function is  $HL_{CL} = i_g/v_i$ , where the grid voltage is assumed to be an ideal voltage source capable of dumping all the harmonic frequencies. If one sets  $v_g = 0$ , i.e.,

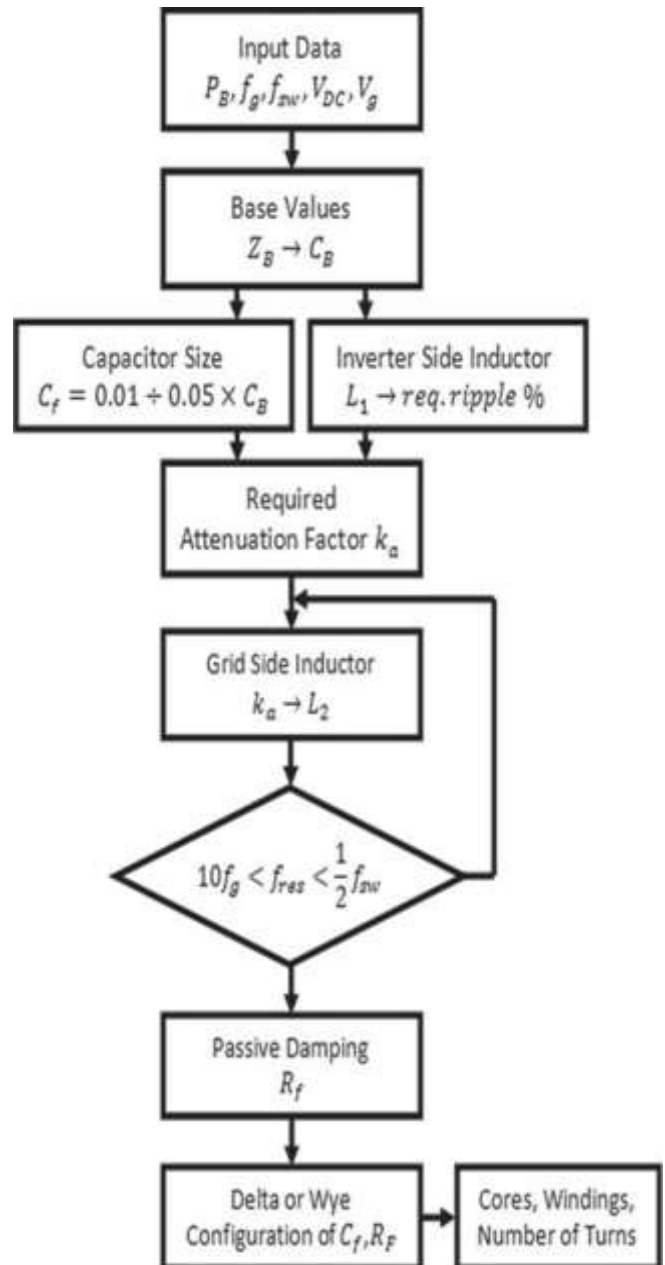

Fig. 4. LCL filter design algorithm.

- Using 10% allowed ripple, gives an inductance  $L_1 = 2.23$  mH.

- The maximum capacitor value is  $16.63 \mu\text{F}$  in order to be within the limit of 5% of the base value of CB. After rounding to the closest commercial value,  $C_f = 15 \mu\text{F}$  for the wye configuration or  $5 \mu\text{F}$  for the delta connection.
- One can set the desired attenuation  $k_a = 20\%$ , and then, using  $L_2$  is found to be  $0.045 \text{ mH}$ .
- Putting all calculated parameters of  $L_1$ ,  $C_f$ , and  $L_2$  into gives  $f_{res} = 6450 \text{ kHz}$ , which meets condition
- Equation gives the damping resistance  $R_f = 0.55\Omega$  for wye configuration or  $1.65 \Omega$  for delta connection.
- The construction of the inductors was defined using the software available on the website of Magnetics and presented in Table II
- The inductor parameters were validated during the experimental setup by taking note of the inductors values when measuring voltage and current with an oscilloscope and multiplied in a spreadsheet in order to compute  $L = (t/i)/V$ .

**V. SIMULATION RESULTS**

A simulation design open loop system as shown in Fig.5 is implemented in MATLAB SIMULINK with the help of coupled inductor, switches and diodes we get desired output voltage level.

**A. Simulation Design open loop**

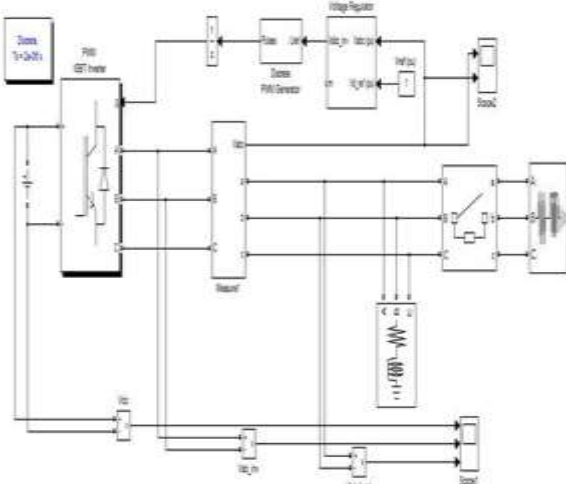

**Fig.5. Open loop system.**

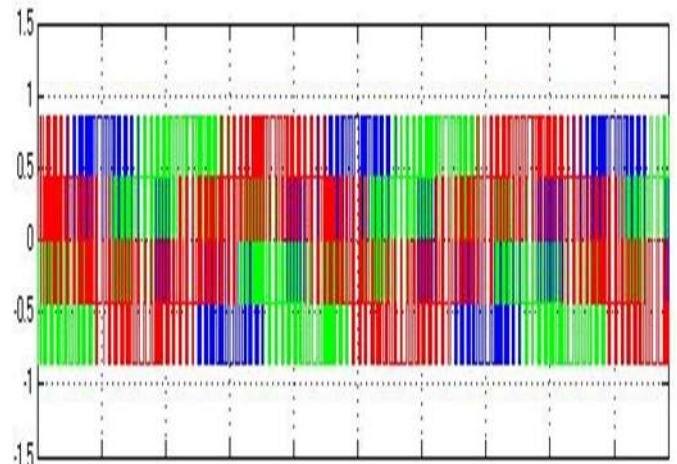

**Fig.6. Output voltage.**

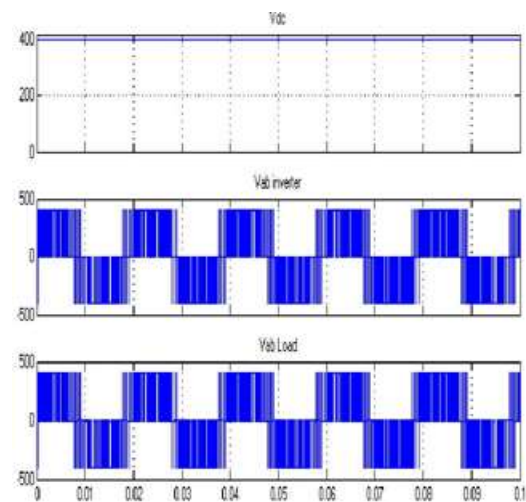

**Fig.7. Input voltage and Load voltage waveform.**

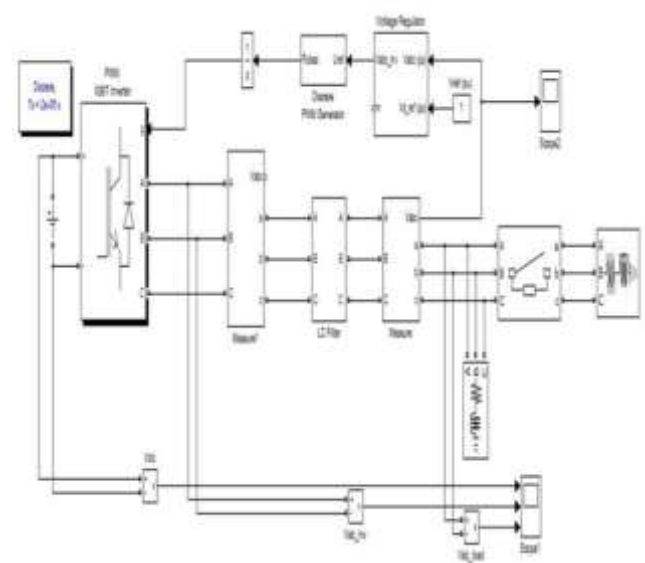

**Fig.8. Stand alone inverter**



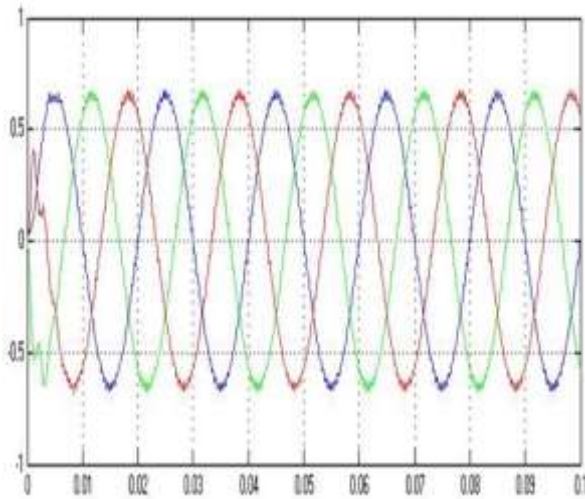

Fig.9. Output Voltage waveform p.u

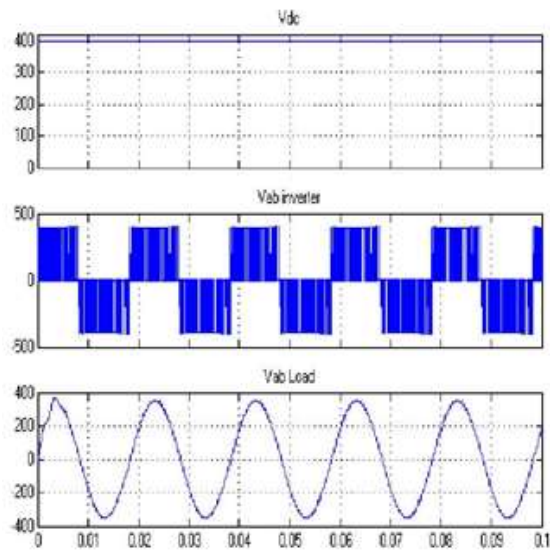

Fig.10. Comparison of three voltages.

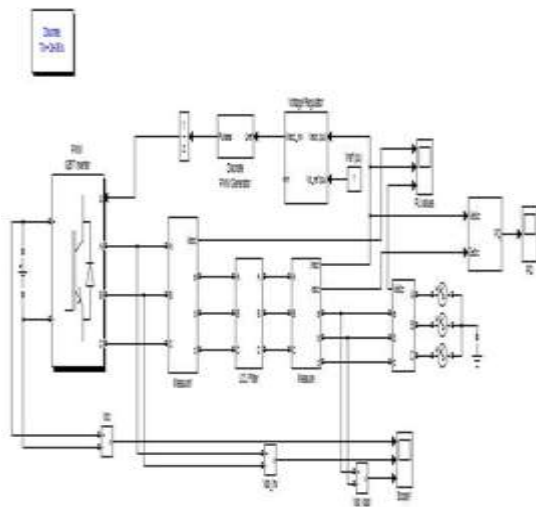

Fig.11. Closed loop circuit of grid connected system.

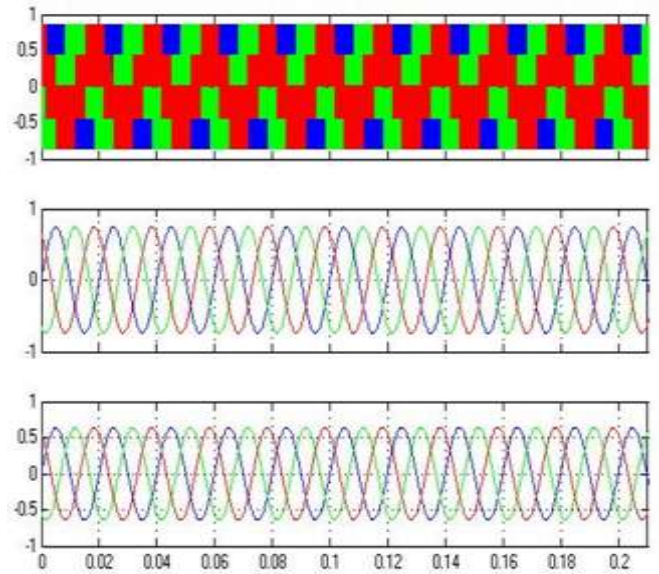

Fig.12. Comparison of three voltages.

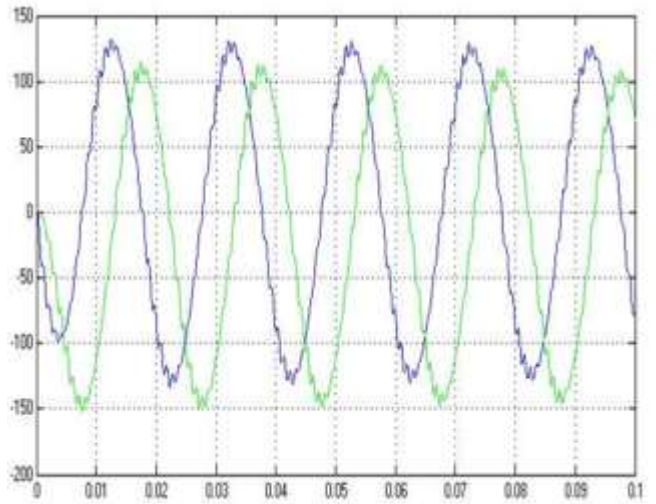

Fig.13. Output voltage of grid connected PV system inverter.

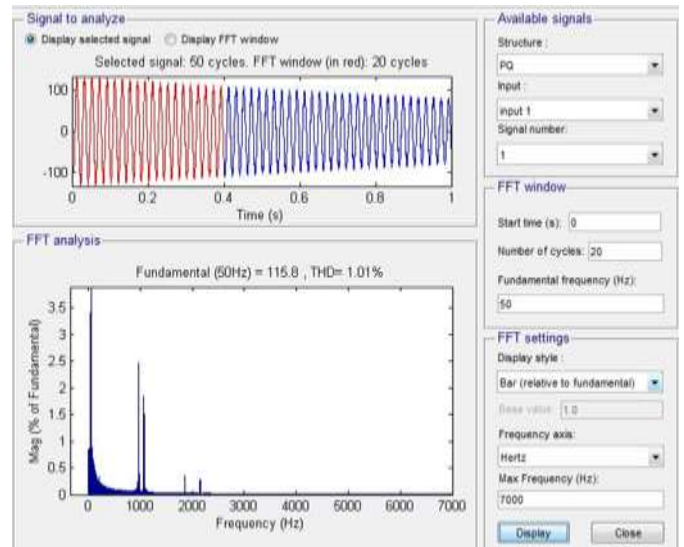

Fig. 14. THD of the proposed system is 1.01%.

## VI. CONCLUSION

From the analysis and experiment, it is well known that:

1. The simulation result indicated that the LCL filter has best high frequency attenuation characteristics, so the LCL filter achieves the best performance than L filter and LC filter.
2. With the same the premise of the suppressing resonance, LCL filter would get better filtering effect when the damping resistor is parallel connected rather than series.

All these features indicate that it is the best design the PV grid-connected inverters with LCL filter parallel-connected damping resistor, especially for small and medium-power inverter PV grid-connected inverters.

## VII. REFERENCES

- [1] F. Liu, X. Zha, and S. Duan, —Three-phase inverter with LCL filter design parameters and research,| Electric Power Systems, March 2010, pp. 110-115.
- [2]X. Zhang, Y. Li, Z. Lin, H. Xu, —LCL filter of voltage-type PWM rectifiers, active damping control,| Electric Drive, vol. 37, no. 11, pp. 22-25, 2007.
- [3]C. Zhang and X. Zhang, PWM rectifier and its control, Beijing: Mechanical Industry Press, 2003
- [4]C. Zhang, Y. Ye, and A. Chen, —Based on the output current control of grid-connected solar power inverter, Electric Power Systems, vol. 22, no. 8, pp. 41-45, 2007.
- [5]M. Liserre, F. Blaabjerg, and S. Hansen, —Design and control of an LCL-filter-based three phase activerectifier, IEEE Transactions on Industry Applications, vol. 41, no. 5, pp. 1281-1290, 2005.
- [6]W. A. Hill and S. C. Kapoor, —Effect of two—level PWM sources on plant power system harmonics,| in Proc. IAS 1998 Conference, St Louis (USA), October 1998, pp. 1300-1303.
- [7]M. Liserre, R. Teodorescu, and F. Blaabjerg, Stabihty of photovohaic and wind turbine grid connected inverters for a large set of grid impedance values,| IEEE Transactions on Power Electronics, vol. 21, no. 1, pp. 263-272, 2006.
- [8]T. C. Y. Wang, Z. Ye, G. Sinha et al., Output tantfilter design for a grid-interconnected three phase inverter,| in Proc. IEEE Power Electronics Specialist Conference, 2003.
- [9]S. V. Araújo, A. Engler, B. Sahan, V. U. Kassel, F. Luiz, and M. Antunes, LCL filter design for grid-connected NPC inverters in offshore wind turbines,| in Proc. 7th Int. Conf. Power Electron., 2007, pp. 1133–1138.
- [10]Inductor Design | Magnetics, Feb. 2, 2013. [Online]. Available: <http://www.mag-inc.com/design/software/inductor-design>
- [11]C. da Silveira Postiglione and M. G. Simoes, —Dspace based implementation of a grid connected smart inverter system,| in Proc. IEEE 12th Workshop COMPEL, 2010, pp. 1–5.
- [12]L. Wenhua, L. Xu, L. Feng, L. Chenglian, and G. Hang, Development of 20 MVA static synchronous compensator,| in Proc. IEEE Power Eng. Soc. Winter Meeting , 2000, vol. 4, pp. 2648–2653.

## Author's Profile:



**Kandur prashanth kumar** has completed his B.Tech in EEE Department from gnyana saraswathi college of engineering & Technology, JNTU Hyderabad. Presently he is pursuing his Masters in Power electronics and electric drives in Arjun college of Technology & Sciences, Hayathnagar(m) , Ranga reddy District, Telangana, India.



**Rosaiah Mudigondla** obtained his Master of Technology in Power electronics and electric drives from Ayaan college of engineering and technology, JNT University, Hyderabad, Telangana, India. His area of interest includes power electronics, power systems and Electrical Machines. He is currently working as an Assistant Professor in Electrical and Electronics Engineering Department in Arjun college of Technology & Science, Ranga reddy District, Telangana, India.