

Applications of Automation Techniques in Smart Grid Technologies

Sushil Chaudhary

Madhav Institute Of Technology & Science. Gwalior INDIA

Abstract—The terms *smart grid*, *Intelligent Grid*, and *secure smart grid* are being used today to describe technologies that automatically and rapidly isolate faults, restore power, monitor demand, and maintain and restore stability for more reliable generation, transmission, and delivery of electric power. This paper focuses on distribution-level protection and automation techniques illustrated with real-world, case study examples. Smart distribution automation not only reacts to maintain or restore stability but also evaluates all available mitigations to use “best choice automation.” A simple example includes evaluating pre- event demand and supply at all points on the system. Using this information and knowledge to predict near-term demand profile changes leads to a best choice reconfiguration strategy. This creates a solution that mitigates the fault or event and provides electricity free of sags, spikes, disturbances, and interruptions.

I. INTRODUCTION

Many exciting innovations are being developed to make end users more aware of the attributes of their energy consumption. With this information, they can make more informed decisions to balance their lifestyle and business requirements as consumers of the grid, in effect becoming educated energy users with a wealth of new “smart” home devices to help them.

This paper focuses on how to maximize the already present but often overlooked smart grid capabilities of the delivery and distribution network known as the grid. The devices that make the grid smart supply measurement, control, and communication, which also facilitate advances and applications of smart in -home devices on the periphery of the grid. The case studies briefly describe three in-service smart grid projects that are using specialized power system awareness devices in distribution applications.

II. PROTECTION, CONTROL, AND MONITORING IEDS DESIGNED BY POWER SYSTEM EXPERTS OFFER SUPERIOR PERFORMANCE

The method of networking robust intelligent electronic devices (IEDs) designed for protection, control, and monitoring (PCM) of the power system creates unmatched performance. Traditional instrumentation and control system devices, such as remote terminal units (RTUs) and programmable logic controllers (PLCs), are designed and manufactured for general purposes, not specifically for power system applications. These generic devices contain little or no default awareness of the functions or components of the power system. They must be customized by the end user, who must create, diagnose, and maintain algorithms and settings for application needs.

End users who are skilled software developers and familiar with apparatus and application requirements must also teach the vendor -specialized processing, memory, and reliability parameters of generic instrumentation and control devices. IEDs are smart even before deployment, due to the expertise and specialized knowledge used during their development.

In general, the terms describe the use of microprocessor-based intelligent electronic devices communicating with one another to accomplish tasks formerly done by humans or left undone. These IEDs observe the state of the power system, make educated decisions, and then take action to preserve the stability and performance of the grid. Technology deployment in the home will allow end users to manage their consumption based on their own preferences. In order to manage their consumption or the demand placed on the grid, consumers need information and an adaptive power delivery system. The smart grid is a collection of information sources and the automatic control system that manages the delivery of power, understands the changes in de-mand, and reacts to it by managing demand response. Different billing strategies for variable time and type of use, as well as conservation and use or sale of distributed resources, will become part of smart solutions.

Two categories of distribution automation systems (DASs) satisfy secure smart grid requirements and differ based on the available communications and desired capabilities. One DAS design has a centralized decision engine, a distribution automation controller (DAC) coordinating communications and logic among the IEDs. This design is called centralized DAS. The second DAS design, distributed DAS, has no DAC but rather the communications and logic operate peer to peer among the IEDs.

The discussion of the centralized DAS techniques references a case study of several systems in use by American Electric Power (AEP), one of the largest electric power utilities in the United States. The discussion of distributed DAS methods refers to a case study of the Public Service Electric and Gas Company (PSE&G) innovative restoration and service stability system. This design has evolved around a standard loop-circuit con-figuration that is easily duplicated throughout large portions of their system.

Information management system drives more efficient energy delivery, reducing the need for added capacity and supporting more informed purchase of bulk power and management of carbon consumption.

III. SMART GRID APPLICATIONS LEVERAGE COMMUNICATION TO MAKE SMART IEDS INFORMED AND ORGANIZED

IEDs used in electric power systems in utility and industrial applications are actually multifunction devices. These IEDs are PCM devices first and foremost but also serve as information and automation sources. As these IEDs acquire power system data and then perform additional calculations and logic, they create a specific local database with knowledge about the power system asset with which they are associated. Therefore, in addition to present power system values, these IEDs record information about the health, performance, and history of the overall power system, as well as specific assets, such as transformers, breakers, and other primary equipment. Therefore, in service, these IEDs are smart and informed.

The protocols and communications channels available in IEDs and communications devices permit the integration of information. Best practice integration methods are developed with an in-depth understanding of the information used to determine the best paths to the appropriate destinations. These methods permit the smart and informed IEDs to communicate data:

- Among IEDs
- To computers and controllers running automatic processes
- To operators and engineers

Thus, with communication, the IEDs become smart, informed, and organized.

IV. SMART GRID DISTRIBUTION AUTOMATION

Power system automation includes processes associated with power generation and delivery. A subset of these processes deals with the delivery of power at transmission and distribution levels, which is power delivery automation. Together, monitoring and control of power delivery systems in the substation and on the pole top reduce the occurrence of outages and shorten the duration of outages that do occur. As the name implies, distribution automation (DA) automates the delivery of power through distribution circuits to homes and businesses.

Although each utility is unique, most consider power delivery automation of transmission and distribution substations and feeders to include:

- Supervisory control and data acquisition (SCADA): operator supervision and control
- DA: fault location, auto isolation, auto sectionalizing, and auto restoration
- Substation automation: breaker failure, reclosing, battery monitoring, dead substation transfer, and substation load transfer
- Energy management system (EMS): load flow, volt-ampere reactive (VAR), voltage monitoring and control, generation control, and transformer and feeder load balancing
- Fault analysis, asset optimization, and device maintenance

Systems without automated control still have the advantage of remote monitoring and operator control of power system devices, including:

- Circuit breakers and automated switches
- Nonautomated switches and fuses
- Capacitor banks
- Voltage control
- Remote power quality monitoring and control

V. PURPOSE-BUILT PROTOCOLS SMARTER THAN SCADA PROTOCOLS

Purpose -built SMART Protocols™, those designed by and for experts in power generation and delivery to satisfy specific purposes, perform dedicated and interleaved multiuser communication. “Smart” IEDs are designed from the beginning to provide a wealth of information about the power system and the apparatus via many different but compatible interleaved communications methods. Data flow among devices dramatically improves individual and networked IED applications.

These protocols support numerous centralized and peer-to-peer communications schemes. Fig. 1 illustrates a simple local-area network (LAN) made of two IEDs that are located near one another, communicating peer to peer.



Fig. 1. Peer-to-peer LAN communications connections

Fig. 2 shows a simple star LAN. A star configuration allows the network controller to use the appropriate protocol and data rate required to communicate with each IED. Each link can be a different collection of interleaved protocols flowing at different speeds; they can even be over different methods (i.e., radio, Ethernet, copper, or fiber serial cables). Although many new systems are designed with each IED speaking a single similar protocol, many in-service IEDs, or smart applications, benefit from a mixture of protocols that allow much more freedom in the selection of devices, because they all do not need to support the same protocol. Another advantage is that the loss of one communications link does not disrupt the rest of the network.

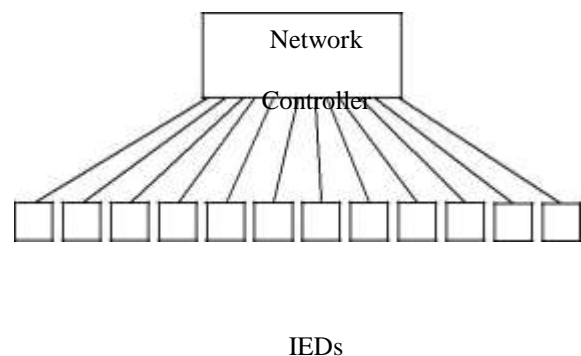

Fig. 2. A star configuration provides a simple and reliable LAN

VI. ORGANIZED, SMART, AND INFORMED IEDS CREATE

SITUATIONAL AWARENESS

Data acquisition and processing within smart IEDs create a wealth of asset information, including present state and historical information about the IED, the power system apparatus being managed by the IED, and network communication. This valuable information provides situational awareness through data on the state, performance, health, and history of the apparatus, the power system, and its surroundings. The different types of data require different methods of processing, storage, and transfer. Data types include:

- IED operation and diagnostics
- Protection quality
- Control indication
- Metering
- Fault information
- Sequential Events Recorder (SER) event notification
- Alarms
- Status
- Apparatus operation and diagnostics
- Equipment health
- Load profile
- Power quality
- Communications channel performance
- Unsolicited data notification
- Weather and environment
- Settings
- Product, software, and firmware revisions

Situational awareness, which is the knowledge of a specific event based on information about past events and the present physical environment, leads to greater productivity of both automated applications and personnel. Networked, smart IEDs further increase productivity by automatically collecting and storing power system data. Examples include monthly relay and breaker operation reports, meter reading reports, breaker condition reports, and transformer thermal monitoring reports. During fault operations, the automatic fault location calculations provided to dispatch centers increase productivity. Using enhanced SER reports and extended alarms at control centers improves the analysis of power system disturbances, resulting in better determination of asset condition and faster service restoration. For example, smart IED networks increase efficiency through better monitoring of transformer loading and temperatures, with the additional information collected from on-site weather stations. The environmental information includes ambient temperature, wind speed and direction, precipitation, and solar radiation. More complete awareness of the transformer situation, such as its history, performance, and true environmental conditions, permits analysis of transformer cooling performance and other asset management. In the end, all departments of the utility, including planning and maintenance, are provided decision-relevant information from the IED network.

VII. SMART IEDS AND CENTRALIZED CONTROL

The DAC functions to detect permanent fault and broken jumper conditions on the distribution network. The DAC acts to isolate the affected section of the feeder and restore power to the unaffected sections from the normal source and from an alternate source, if available. After a well-planned design phase, the DAC logic follows these simple sequential steps:

1. Initialize – the DAC powers up and checks startup conditions and parameters.
2. Unarm – after initialization, the DAC is prepared but unarmed until commanded or automatically put in service.
3. Ready – once armed, the DAC monitors system conditions for trigger states.
4. Update – the system senses and reports system conditions and changes in status to the DAC.
5. Analyze – the DAC processes system parameter changes to determine appropriate action.
6. Isolate – the DAC operates controllable points in the network to de-energize faulted segments.
7. Restore – the DAC re-energizes all nonfaulted segments and isolates permanent faults to the smallest possible segment.
8. Return to Step 4.

A. Centralized Communication, Centralized Decision Making

The communication for centralized systems can be deployed in a star configuration, as shown in Fig. 2, or via looped communication, as illustrated in Fig. 3, where the DAC acts as the controller for both the DA and the communications network. The simplified installation example in Fig. 3 demonstrates the AEP centralized DAC that uses meshed radios and multidrop communication to collect information from all of the relays and recloser controls, in addition to making centralized automation decisions.

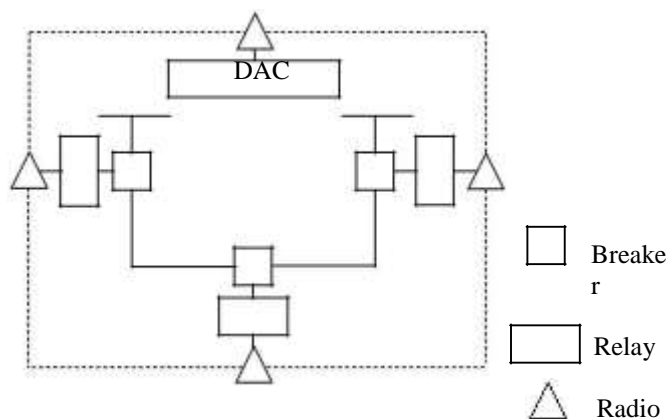

Fig. 3. A simplified illustration of centralized data collection and decision making within the DAC

B. Analyze, Isolate, and Restore

The centralized logic engine performs analysis to detect permanent faults, broken jumpers, loss of substation source, and lockout due to miscoordinated protective devices. During the design phase, the distribution network is broken into zones: feeder sections that can be isolated or energized from one or more sources using fault interrupting or switching devices (i.e., breaker, recloser, load-break switch, etc.). The DAC evaluates system conditions to determine if any unfaulted zones are de-energized. If so, it automatically restores unfaulted zones using alternative sources (if available). In addition, it changes settings groups within the IEDs to better coordinate protective devices in the new network topology. Finally, the DAC restores upstream zones that were de-energized due to miscoordination of the protective devices.

C. Flexible Solution

The system was carefully chosen to accommodate various sizes of automation systems so it can be scaled to any application that AEP wants. Without modifications, the present system coordinates up to six sources and 100 devices. The DAC integrates virtually any available distribution device using a serial or Ethernet connection with various protocols, including DNP3 serial, DNP3 LAN/WAN (wide-area network), SMART Protocols (including MIRRORED BITS[®] communications, Fast Message, and Fast Operate), Modbus[®], RTU/TCP (Transmission Control Protocol), and more.

D. Restoration From Alternate Sources

The system carefully supervises restoration from alternative sources based on user -defined conditions, such as abnormal circuit configuration, hot-line tags, nonreclose status, supervisory control disabled, or communications failure. Alternate sources are selected based on zone load and available feeder capacity to avoid cascading problems.

E. Automate Return to Normal

Once utility personnel repair the affected zone, SCADA operators can issue a single command to systematically return the feeders to normal. The device settings are also automatically returned to normal quickly and easily via settings groups.

F. Easy to Configure

The system deployed by AEP is programmed using simple drag-and-drop IEC 61131 function block objects. This way, the system configuration is nonvendor specific, is based on international standard methods, and requires no extensive training.

G. SCADA System Connectivity

The DAC creates a system-wide database and then provides metering, status, and alarms to SCADA. Operators view the system topology and load values by zone and remotely control the devices. The distribution automation system (DAS) supports various communications protocols in

the event AEP changes their SCADA system in the future or chooses to share information with neighboring utilities.

H. DAC Scheme Verification

The DAC includes a custom user interface screen that personnel use to verify the scheme functionality via virtual dispatch. Virtual dispatch performs all actions except operation of the switch. It also tests the DAC processing, control commands, and communications by operating the recloser controllers with the bypass switch closed on the feeders. The virtual dispatch function permits testing of all scenarios without adversely affecting the in-service IEDs or customers.

Also, point-by-point verification of the protocol mapping of data items is quickly verified between the DAC and the field devices.

Finally, real-time data collection gathers and stores event data so that waveforms, reports, and sequential event records are available for post-event analysis.

VIII. PSE &G DA VIA SMART IEDS COMMUNICATING

PEER TO PEER

Public Service Electric and Gas Company (PSE&G) recognizes the ever -increasing importance of electricity in everyone's life and that excellent service reliability is no longer a luxury in the eyes of consumers but an expectation. In this day and age of digital everything, momentary outages, or "blinks," are perceived by customers as equally disruptive as short outages. Therefore, PSE&G set out to install an automated feeder reconfiguration scheme that not only minimizes the duration and number of customers impacted by an outage due to a fault but also reduces the number of customers experiencing a blink for the fault and subsequent switching.

A. Peer-to-Peer Communications, Peer-to-Peer Awareness

Leveraging the technology available today in the latest generation of relays and recloser controls along with fiber-optic communication, PSE&G implemented a scheme designed to improve reliability numbers. The advanced loop scheme (ALS) builds on the utility's standard distribution scheme that used a normally open tie to separate two feeders. The original scheme offered automatic reconfiguration but was inherently slow and subjected customers to unnecessary blinks when the tie closed on a fault. Using peer-to-peer communication, as illustrated in Fig. 1, the ALS eliminates closing on a fault for a reconfiguration operation. The scheme uses a "close before open" methodology in which the tie is closed prior to sectionalizing taking place. Because of this manner of operation, customers on unfaulted line sections are not exposed to an outage for the fault or switching taking place to isolate the faulted line section. Additionally, with communication comes the ability to improve protection and add more protective devices along the feeders to reduce the number of customers per section.

B. Decentralized Communication, Decentralized Decision Making

As illustrated in Fig. 4, each IED communicates with two neighboring IEDs. Each IED creates information and collects it from others to make decisions. These data resulting from local calculation and message subscription are then sent to neighboring IEDs, where the data are again used for localized decision making.

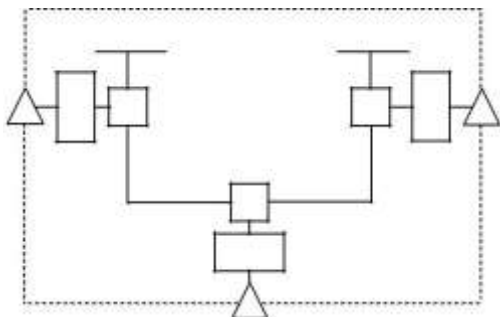

Fig. 4. A simplified illustration of peer-to-peer communication and shared decision making among neighboring IEDs

People are using more and more electricity to power their lives. As the demand for electricity grows, so does the expectation for reliable electric service, which is why the PSE&G Electric Delivery Group is making a significant investment in ALS, a new technology to help improve reliability. ALS was developed in association with Distribution Vision 2010 (DV2010), a consortium of six utilities, including PSE&G, partnered to enhance reliability in the utility industry.

“Historically, PSE&G improved reliability by trimming trees, using lightning arrestors, and replacing poles, which may or may not have had a measurable impact,” explained Dick Wernsing, PSE&G’s reliability-centered maintenance expert. “Today, thanks to technology like ALS, we can focus our investments and achieve measurable improvements in reliability.”

The ALS concept is simple. The average 13 kV circuit serves about 3,000 customers and is divided in two sections, each serving approximately 1,500 customers. When a fault occurs on one of the traditional circuit sections, 1,500 customers experience an extended outage, and the customers on the other section experience a momentary outage.

ALS targets smaller customer groups by dividing the circuit into sections of 500 customers each. When a fault occurs in a section, only the customers in that section are interrupted. The other customers on the circuit do not experience any interruptions, due to high-speed selective relaying using fiber-optic communication that allows only the faulted section to be interrupted. The advanced technology identifies the fault, closes the feeder -tie recloser before other customers are impacted, and clears the fault in less than a second. This results in a reduction in the number and duration of customer outages, which in turn improves the results of the System Average Interruption Frequency Index (SAIFI, average number of customer interruptions) and the Momentary Average Interruption Frequency Index (MAIFI, average number of momentary outages).

IX. EXCEL ENERGY SMART SUBSTATION AND

SMARTGRIDCITY™

The EXcel Energy Smart Substation installation is a substation automation system (SAS) illustrating Xcel Energy’s desire to implement state-of-the-art monitoring and control equipment. Many of their existing protection and control systems are based on electromechanical systems, as shown in Fig. 5, which lack the computing, memory, or communications capabilities required to be smart.



Fig. 5. Many discrete components lack the computing, memory, or communications capabilities required to be smart

The equipment that creates a smart SAS is deployed as a network of IEDs communicating to one another and a network information processor to provide protection, automation, control, and monitoring. The system includes IEDs installed in a predesigned, pre-engineered, and rebuilt drop-in control building and a collection of field termination cabinets. Fig. 6 illustrates how few smart IEDs it takes to replace the discrete components in Fig. 5 and also provide much more functionality.



Fig. 6. A few smart and automated devices replace many discrete components

Field cabinets, such as the one shown in Fig. 7, contain feeder breaker IEDs close to the apparatus.



Fig. 7. A smart, automated, and distributed device installed local to the grid apparatus that it protects, controls, and manages

SmartGridCity actually expands on the capability of a network of IEDs communicating among one another to include two substations and several distribution feeder circuits. Thus, the smart technologies demonstrate a small, coordinated service territory to show the power of this technology across an entire utility.

Each system provides much more than typical substation systems that simply indicate the present state and allow remote control. These projects enable operators to perform all functions remotely and eliminate the need for hands-on monitoring. The systems reduce installation and maintenance costs, improve personnel safety and equipment life, restore the power system faster after outages, and increase power system reliability.

Both the Xcel Energy Smart Substation and SmartGridCity designs demonstrate the following advantages based on full deployment of new and existing technologies.

A. Organized, Smart, and Informed IEDs Create Situational Awareness

Networks made of IEDs communicating together create, communicate, process, and react to power system information. Individual IEDs create information as they perform local PCM by acquiring analog and digital data and then calculating power system information. This information is then disseminated to other users and processes throughout the power system via networked communications, available to be acted upon and/or stored for later use. At Xcel Energy, these data are used to improve reliability metrics, such as System Average Interruption Duration Index (SAIDI) and Customer Average Interruption Duration Index (CAIDI).

B. SmartGridCity Improves Customer Reliability With Smart DA

One of the primary benefits of using IEDs in conjunction with a DA scheme is improved reliability and customer experience. Xcel Energy's corporate website states that "by reducing customer minutes out through fault switching, auto-matic outage notifications and proactive asset replacement, Xcel Energy expects to improve SAIDI by 10 percent" [1].

C. Deployment of Functionality Available but Often Unused Within In-Service IEDs

The combined data and intelligence created by sharing data among the IEDs creates a true awareness of the power system. This unique capability has never been deployed to date, because most systems use only a fraction of the network capabilities. These systems make greater use of smart product characteristics built into the IEDs to create a system capable of making observations and decisions and then taking action. This contrasts with currently available systems that simply provide a snapshot of present values with no opportunity to understand trends in power system activity, system performance, or apparatus degradation.

D. Accurate Time Everywhere

Both the IED SAS networks and the additional pole-top and field terminal cabinet IED installations are time-synchronized with highly accurate global positioning satellite (GPS) clocks and IRIG -B time distribution. IED in substations and associated pole tops measure, process, and time-stamp data via internal clocks synchronized to the same GPS source. This contrasts with IED systems that are only synchronized locally or not at all, which prohibit accurate diagnostics or analysis of events.

E. Benefits of Time-Aligned Data

IED network data are more useful and valuable when all IEDs in a system are synchronized. Further, the utility of existing systems, such as SCADA and asset management, are improved when the condition of the incoming data is improved. Without changing communication or settings, SCADA and asset management views are more useful, because measurements taken at the same instant are presented to the user. This contrasts with all SCADA systems available today that display data without regard for or awareness of when they were measured.

F. Time-Synchronized Measurements Provide Smarter Data From Fewer Devices

All devices can be time-synchronized via GPS time-synchronization clocks. These clocks have become very small and inexpensive so that they can be installed anywhere in the system, synchronize processes within remote devices, and make the produced data smarter. The time-synchronized devices synchronously sample the power system and capture present system measurements at the same instant in time. Local results of synchrophasor processing translate into automatic control actions that are issued in real time and based on a collective understanding of the entire system. With this powerful technology, formerly complex applications, such as system integrity protection schemes (SIPSs) and assessment of power system stability over large geographical areas, are

easier to implement, have fewer components, and are more reliable than traditional solutions. Data are smarter, because they are created and used with a coordinated understanding of data from neighboring and remote devices across the system.

G. Travel Only After Station Makes Contact Via Text Messaging and Email

Data from IEDs representing protection, automation, equipment monitoring, asset management, environmental monitoring, wide-area measurement, and situational awareness trigger direct contact to personnel. This function demonstrates that the substation can be remotely monitored. Engineers, technicians, and service personnel only need to travel to the substation after it contacts them and they decide maintenance is required. The smart IED network sends email, pages, and text messages to remote people or processes. This crucial, self-initiated communication provides connection and cybersecurity and performs unsolicited indication of problems. The messages go directly to processes or personnel that can take action and include useful information, such as a power disturbance summary that includes fault location data. This contrasts with traditional systems that rely on SCADA operators to detect a problem and dispatch a crew to the station or schedule visits to look for problems. The smart network delivers useful information directly to the people who can help and allows them to travel directly to the location of the problem with the right truck, tools, and personnel.

H. More Efficient Energy Purchase and Delivery

The application of IEDs and DA enables Xcel Energy to reduce the amount of line loss caused by conductor impedance by redistributing power flow. As a result, Xcel Energy can supply its customers with the same amount of power with less generation, since less electricity is lost between generation and delivery. Load-balancing DA, remote capacitor bank operation, and remote transformer sensing enable this redistribution, the result of which is a decrease in carbon emissions. Lower generation demand facilitated by more efficient electricity delivery also extends the life of generation equipment, reducing (or at least delaying) capital expenditures and reducing waste. Additionally, smart measurement of equipment and grid health allows Xcel Energy to improve power delivery to its consumers by replacing equipment as it nears the end of its life.

Smart measurement and control reduces carbon emissions in other ways as well. Load balancing through measurement and communication that prevents grid unbalance allows transmission and distribution networks to handle load fluctuation without increasing generation. An additional coal-fired plant, for example, may never need to be started up, if consumer demand is satisfied by efficiently transported and distributed electricity. Even utilities that rely wholly on nonrenewable energy benefit from smoothed load, and generation facilities reserved primarily for peak load conditions may not need to run as frequently, if at all.

I. Visibility and Management of Carbon Consumption

As Xcel Energy improves power delivery efficiency through the application of IEDs and DA, its customers are increasingly empowered to participate in efficiency improvement as well. In-home price and environmental signals tied to peak load periods affect consumption. Although consumer response to price signals is a function of demand elasticity and overall price levels, Xcel Energy anticipates that informed consumers will make better financial and environmental choices. When higher prices correlate to peak load periods, price-sensitive or environmentally conscious customers chose to delay power use. The resulting smoothed demand, like the distribution efficiencies enabled by IEDs and DA at the utility level, reduces generation needs. Price and environmental signals also make the case for distributed generation more attractive. Many Xcel Energy customers have installed rooftop solar panels to power their homes (and in some cases, vehicles), selling unused energy back to Xcel Energy at a profit.

X. CONCLUSIONS

DASs and IEDs widely used in electric power systems are the building blocks of a smarter, more reliable grid. AEP, PSE&G, and Xcel Energy apply these technologies in different ways to meet their reliability goals. Automatic reconfiguration and outage notification enable the utilities to provide their customers with more reliable service. Xcel Energy places additional focus on leveraging smart technologies to better inform its customers and reduce overall carbon emissions. Perhaps most important is that each installation makes financial sense. The measurable benefits of each application demonstrate a tangible return on investment via documented business decision-making information.

REFERENCES

- [1]. "Xcel Energy SmartGridCity™ Benefits Hypothesis Summary." Available: http://smartgridcity.xcelenergy.com/media/pdf/SmartGridCityHypothesisWhitePaper_July2008.pdf.
- [2] [Online]. Available: Ministry of Power, Government of India Website, <http://powermin.nic.in>, Nov. 2009.
- [3] Y. Pradeep, S. A. Khaparde, R. Kumar, "Intelligent Grid Initiatives in India," *IEEE Intl. Conf. on Intelligent Systems Applications to Power Systems*, pp. 1-6, Nov. 2007.
- [4] S. Massoud Amin and B.F. Wollenberg, "Toward a SmartGrid: power delivery for the 21st century," *IEEE Power and Energy Magazine*, Vol. 3, No. 5, pp. 34-41, Sept.-Oct. 2005.
- [5] E. Richard Brown, "Impact of Smart Grid on distribution system design," *Industry Applications Conference*, Oct. 2008.
- [6] V. S. K. Murthy Balijepalli, R. P. Gupta, and S. A. Khaparde, "Towards Indian Smart Grids," in *IEEE TENCON Conference*, Singapore, Nov. 2009.